

READING X, Y COORDINATES WITH OPTICAL MOUSE AND SENDING DATA VIA INTERNET WITH NODEMCU-ESP8266

M. TODICA^{1,*}

ABSTRACT. The work demonstrates the possibility to read the x, y coordinates of a moving object using an optical PC mouse and send the data to Android devices (smartphone or tablet) using the NodeMcu-ESP 8266 board. The system was used to control a small robot car with a smartphone via internet. The method can be usefully for didactic and scientific experiments.

Keywords: optical mouse, x, y coordinates, NodeMcu-ESP8266.

INTRODUCTION

Reading the x, y coordinates of a moving object is not a new idea, but achieving this task with simple, cheap and reliable materials represents an interesting challenge. Such kind of task is required for the control of the displacement of different mobile parts of complex mechanisms like industrial machines or robots, 3d printers, etc. Usually this operation is performed with different sensors like rotary encoders, ultrasound radars, optical switches, and so on, attached to the moving parts of the mechanical system [1-3]. The distance is measured by counting the number of passes

¹ "Babes-Bolyai" University, Faculty of Physics, M. Kogalniceanu No 1, 400084 Cluj-Napoca, Romania

* Corresponding author: mihai.todica@phys.ubbcluj.ro

of the sensor in front of particularly points of a given stationary reference frame. Specific system of sensors for each application is requested. The accuracy is determined by the precision of the mechanical system of the sensors. For ordinary equipment this accuracy lies in the domain 0.1-1 mm. Better accuracy request very sophisticated and expensive mechanical devices, those used is justified only for complex machinery. However some times we need to obtain good accuracy with cheap equipment. A simple and reliable solution is the use of an ordinary PC mouse. The idea starts from the observation that every small displacement of the mouse on a smooth surface is followed by fine displacement of the cursor on the screen of the PC. The accuracy is of the order of hundreds or thousands dpi, depending on the quality of the mouse. This accuracy is enough to measure small displacements of different mechanisms or simple robots. The mouse is attached to the moving object without special adapters. The only requirement is to ensure continuous displacement of the mouse in front of a smooth fixed surface. It is possible to use for this job a mechanical or optical mouse, but the last one is less influenced by the errors determined by the motion or by the change of direction of the motion. It is the option chosen for his work.

Another feature required to the intelligent devices is the possibility to send and receive the data trough the internet. There are a lot of specific devices and protocols performing this task, but a simple solution is the use of the module ModeMcu ESP 8226 and Blynk application. We used this module and an optical mouse to read the x, y coordinates of a small robot car, controlled by smartphone via the internet. The work can be regarded as the starting point for the development of more complex equipments.

EXPERIMENTAL

The optical mouse used for this work contain the chip ADNS 2610, but other chips like ADNS 3610 or equivalent can be used. No special modifications of the mouse are requested. The useful information are collected directly from the pins SDIO (pin 3) and SCLK (pin4) of the chip

ADNS 2601, [4]. Because the mouse is +5V operating and the board NodeMcu supports only +3.3V signals, a logic level converter is intercalated between the chip and the NodeMcu board. The mouse is connected to high voltage pins and the NodeMcu to low voltage of the converter. The SDIO of the mouse is connected to the pin D1 and SCLK to pin D2 of NodeMcu. The +5V are available on the pin VU of NodeMcu. It is necessarily to connect the low pin LV of the logic converter to +3.3V and the HV pin to +5V,

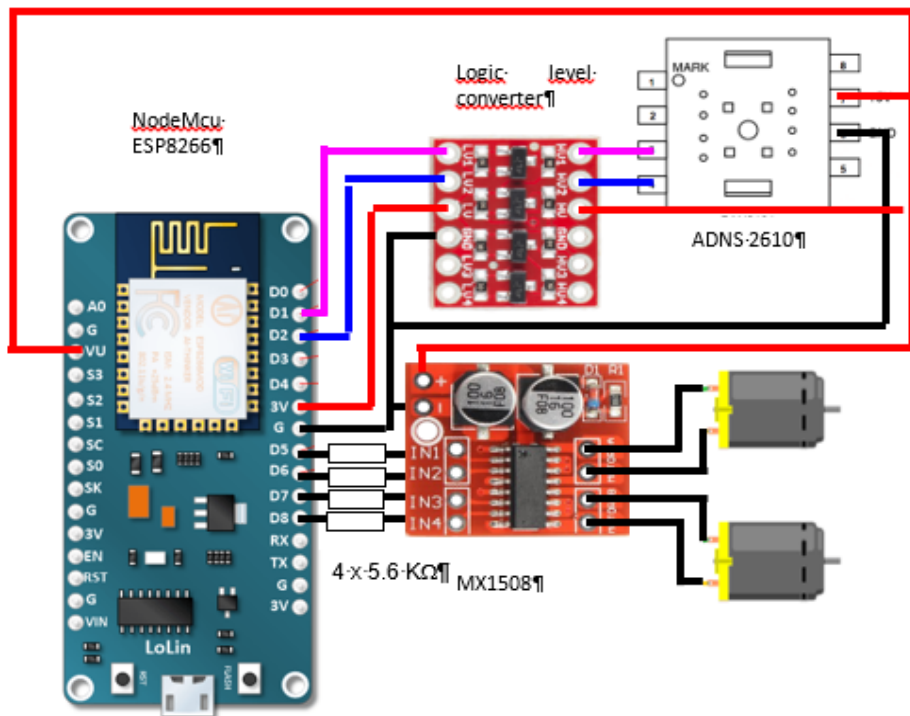

Fig.-1. Electrical diagram of the circuit

otherwise the converter is not working. The mouse was attached to a small car robot, driven by two DC motors. The motors are connected to the NodeMcu board through a H bridge, (MX1508). The entries IN1, IN2, IN3 and IN4 of the bridge are connected to pins D5, D6, D7 and D8 of NodeMcu and the DC motors to the corresponding outputs of the bridge. The bridge and

the motors can be powered by the same source as the NodeMcu board, but for powerful motors we need separately source. In this case the pins + and - of the H bridge and the motors must be connected to this external source, but ensuring common ground with the NodeMcu board. The whole system is powered with +5V via USB port, or by external 5 - 9V connected to pins VIN and G of NodeMcu. The electric connections are shown in figure 1.

RESULTS AND DISCUSSION

The project is based on the properties of the optical mouse to identify every motion by comparing two successive images of the surface traveling in front of its camera. The difference between the images is transformed in x, y coordinates. The principle of work is well known and described in literature, [5]. For some mouse, especially the ancient ones, the rough x, y data are available before being processed by its own microcontroller, and before being sent to the PC. It is the situation of the chips ADNS 2610, 3610, etc. [4]. These data are sent to the NodeMcu board and processed by its microcontroller, CH 340, CP 2102, or equivalent. This microcontroller is compatible with Arduino platform and can be programmed using C+ language, [6, 7]. Programming the NodeMcu board request the installation of the Arduino IDE on the computer and the setting of the application to recognize and communicate with the NodeMcu board, [8, 9].

Brief description of the procedure is presented below:

- Download and install the version Arduino 1.6.8 or latter, [6].
- Add the information of the board ESP8266 to the Arduino. Open the Arduino IDE, go to the menu File/ Preference, and introduce into the box **Additional Boards Manager URLs**, the address of the board of JSON file ESP8266, http://arduino.esp8266.com/package_esp8266com_index.json.
- Manage the ESP library. In the Arduino IDE go to the menu Sketch/ Include Library/ Manage Libraries/ and add the Library of ESP8266.
- Select the NodeMcuESP8266 board. Go to menu Tools/ Board/ Boards Manager/. Select NodeMCU 1.0 (ESP-12E Module)

- Download and install **Blynk library** 0.4.0 from the official site, [10].

At this stage the Arduino is able to recognize and communicate with the board. To ensure the control of the robot car and the transmission of data through the internet we must install the Blynk application on the smartphone, available on Google Magazine Play, and set the credentials of the internet router. The procedure is the follows:

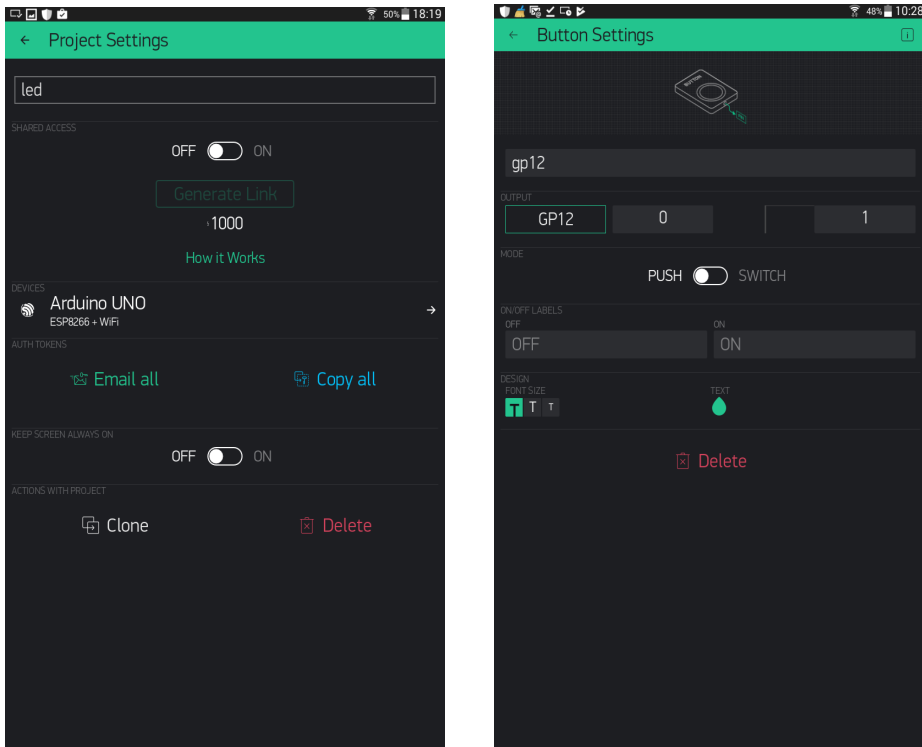

Fig. 2. Setting the Blynk workspace

- Open the app, create an account, enter a valid email address and the password, register, and **Sign Up**.

- Open new project, give it a name, creates the **auth. char** and send it to the above e-mail address. Select the **ESP8266 WiFi** board, (Fig. 2).

- Add the desired widgets to the workspace of the Blynk. For our project we used only four widgets buttons attached to digital pins GP 12,

13, 14 and 15, for the control of the two motors of the robot car, and one widget terminal on V12 displays the x, y coordinated of the mouse. The HIGH state is applied to the entries IN1 – IN4 of the H bridge when the buttons are pushed. So the two motors can be controlled separately or together, forward or backward, in any order. A supplementary widget button was added to virtual pin V1 for resetting the data sent by the mouse. Now the Blynk application is ready to control the NodeMcu board via internet.

In the next stage the board NodeMcu must be programmed. First we need to download the library **OptiMouse-master** from GitHub site and install it on the Arduino IDE, [11, 12].

Then we upload the below code:

The code.

```

////////////////////////////////////
#include <ESP8266WiFi.h>
#include <BlynkSimpleEsp8266.h>
#include <SimpleTimer.h>
SimpleTimer timer;
char auth[] = "put there the auth. char of Blynk";
char ssid[] = "put there the SSID of the router";
char pass[] = "put there the password of the router";
#include "PAN3101.h"
#define SDIO D2
//attach SDIO pin of the mouse to D2 pin of NodeMcu
#define SCLK D1
//attach SCLK pin of the mouse to D1 pin of NodeMcu
PAN3101 Optical1 = PAN3101(SCLK, SDIO);
signed long x = 0;
signed long y = 0;

void setup()
{
  Serial.begin(115200);

```

```

Optical1.begin();
Blynk.begin(auth, ssid, pass);
timer.setInterval(1000L, sendUptime);
delay(100);
}

BLYNK_WRITE(V1)
{
int Value = param.asInt();
//reset the data sent by the mouse when V1 widget is pressed
if (Value=1)
{
Serial.print("Reset prin V1 ");
x=0;
y=0;
Blynk.virtualWrite(12, " RESET ");
}
}

void sendUptime()
{
x += Optical1.dx();
y += Optical1.dy();
//optional, displays the data on the PC monitor
Serial.print("x=");
Serial.print(x, DEC);
Serial.print(" y=");
Serial.print(y, DEC);
Serial.println();
//displays the data on the smartphone
Blynk.virtualWrite(12, " X= ");
Blynk.virtualWrite(12, x);
}

```

```

Blynk.virtualWrite(12, " Y= ");
Blynk.virtualWrite(12, y);
}

void loop()
{
Blynk.run(); // Initiates Blynk
timer.run();
}
////////////////////
End of the code.

```

It is necessarily to introduce in this code the **auth. char** of the Blynk project, the **SSID** and the **password** of the local internet router. Once the code was uploaded, the NodeMcu board can be disconnected from the computer and powered by external source. Open the project on the Blynk application on the smartphone and send commands to the motors by pushing the buttons GP12-15. When the robot car is moving, the mouse coordinates will be displayed on the widget terminal. By pushing the widget button V1 the data are resets.

CONCLUSION

The work demonstrates the possibility to read and send the x, y coordinates of the moving object trough the internet with very simple equipment. The displacement sensor is an PC optical mouse, which offer a resolution of the order of hundred dpi, and the connection to the internet is realized with the NodeMcu-ESP8266 board. With the application Blynk, a bilateral communication between the Android device, smartphone or tablet, and this board is established. This facility was used to control a small robot car with the Android device.

REFERENCES

1. I. Burda, Microprocesoare si microcontrolere, Presa Universitară Clujeană, Cluj-Napoca, **2002**, ISBN 973-610-046-4.
2. S. D. Anghel, Bazele Electronicii analogice si digitale, Presa Universitară Clujeană, Cluj-Napoca, **2007**, ISBN: 978-973-610-554-8
3. A Tunyagi, K Kandrai, Z Fülöp, Z Kapusi and A Simon, Phys. Educ. 53 (2018) 035028 (9pp)
4. www.efo.ru/components/avago/catalog/5988-9774EN.pdf
5. Richard F. Lyon, The Optical Mouse, and an Architectural Methodology for Smart Digital Sensors, Xerox Corporation, Palo Alto Research Center,
6. www.dicklyon.com/tech/OMouse/OpticalMouse-Lyon.pdf.
7. Arduino Website (www.arduino.cc/en/Guide/ Introduction)
8. T. A. Antal, Acta Technica Napocensis, Series: Applied Mathematics, Mechanics, and Engineering, Vol. 60, Issue I, March, (2017).
9. <http://www.instructables.com/id/Programming-ESP8266-ESP-12E-NodeMCU-Using-Arduino/>
10. M. Todica, Controlling by smartphone via internet two relays with Blynk and ESP 8266-01, DOI: 10.13140/RG.2.2.31986.91847
11. Blynk Website: <http://www.blynk.cc/getting-started/>
12. <https://github.com/zapmaker/OptiMouse>,
13. Martijn The. <http://www.martijnthe.nl/>

