



STUDIA UNIVERSITATIS  
BABEŞ-BOLYAI



# OECONOMICA

---

2/2014

**STUDIA**  
**UNIVERSITATIS BABEȘ-BOLYAI**  
**OECONOMICA**

**2/2014**

**August**

## EDITORIAL BOARD

### EDITOR:

**Dumitru Matis**

Babeş-Bolyai University, Cluj-Napoca, ROMANIA

### EXECUTIVE EDITORS:

**Cristian Dragoş**

Babeş-Bolyai University, Cluj-Napoca, ROMANIA

**Monica Zaharie**

Babeş-Bolyai University, Cluj-Napoca, ROMANIA

## ADVISORY BOARD

**Dana Bako**

Babeş-Bolyai University, Cluj-Napoca, ROMANIA

**Ivan Bélyacz**

Pécs University, Pécs, HUNGARY

**Gabriela Bodea**

Babeş-Bolyai University, Cluj-Napoca, ROMANIA

**Anca Borza**

Babeş-Bolyai University, Cluj-Napoca, ROMANIA

**Attila Chikan**

Corvinus University, Budapest, HUNGARY

**Gheorghe Ciobanu**

Babeş-Bolyai University, Cluj-Napoca, ROMANIA

**Mihaela Drăgan**

Babeş-Bolyai University, Cluj-Napoca, ROMANIA

**Diana Filip**

Babeş-Bolyai University, Cluj-Napoca, ROMANIA

**Daniel Glaser-Segura**

San Antonio University, Texas, USA

**Gyula Horváth**

Pécs University, Pécs, HUNGARY

**Dorina Lazăr**

Babeş-Bolyai University, Cluj-Napoca, ROMANIA

**Dirk Morschett**

Saarlandes University, Saarbrücken, GERMANY

**Maria Parlińska**

University of Warsaw, POLAND

**Ernesto Volpe Di Prignano**

La Sapienza University, Rome, ITALY

**Adrian Pop**

University of Nantes, FRANCE

**Patrick Villieu**

University of Orleans, FRANCE

**Roxana Stegorean**

Babeş-Bolyai University, Cluj-Napoca, ROMANIA

**Vincent Šoltés**

University of Košice, SLOVAKIA

**Daniel Stavarek**

Silesian University, Karvina, CZECH REPUBLIC

**Bernhard Swoboda**

University of Trier, Germany

**Aida Sy**

Manhattan College, New York, USA

**Adriana Tiron-Tudor**

Babeş-Bolyai University, Cluj-Napoca, ROMANIA

**Alexandru Todea**

Babeş-Bolyai University, Cluj-Napoca, ROMANIA

## EDITORIAL ASISTANTS

**Dan Sitar-Taut**, Babeş-Bolyai University, Cluj-Napoca, ROMANIA  
**Gabriela Brendea**, Babeş-Bolyai University, Cluj-Napoca, ROMANIA

**YEAR**  
**MONTH**  
**ISSUE**

**(Volume 59) 2014**  
**AUGUST**  
**2**

# **STUDIA UBB OECONOMICA 2**

---

**EDITORIAL OFFICE OF OECONOMICA:**

Teodor Mihali str. no. 58-60, s. 251, 400591 Cluj-Napoca,  
Phone: 0040-264-41.86.52, [oeconomica@econ.ubbcluj.ro](mailto:oeconomica@econ.ubbcluj.ro),  
<http://studiaoeconomica.ubbcluj.ro/>

---

## **SUMAR – SOMMAIRE – CONTENTS – INHALT**

N. DA SILVA-ESCLANA OVER THE COUNTER HOMEOPATHY: EXPLORING PARENTAL ATTITUDE .....	3
A. TUDOR-TIRON, I. DRAGU FROM SUSTAINABILITY TO INTEGRATED REPORTING – THE POLITICAL PERSPECTIVE OF INSTITUTIONAL THEORY .....	20
N. DLODLO THE INFLUENCE OF SELECTED MOBILE-DEVICE RECREATION FACTORS ON QUALITY OF LIFE: A GENDER-BASED PERSPECTIVE ..	34
M. SIMIONESCU THE ASSESSMENT OF INCOME CONVERGENCE HYPOTHESIS IN ROMANIAN COUNTIES USING THE PANEL UNIT ROOT APPROACH ...	57

S. HUSSAIN, H.H. NAYAB, F. SHAHZAD, Z. FAREED, Z. ABIDAN  
AN EMPIRICAL INVESTIGATION OF ENTREPRENEURIAL  
INTENTIONS AMONG BUSINESS STUDENTS OF PAKISTAN ..... 68

## OVER THE COUNTER HOMEOPATHY: EXPLORING PARENTAL ATTITUDE

**Natasha DA SILVA-ESCLANA\***

University of South Africa, South Africa

**Abstract.** This study explored the attitude of parents with children in early childhood development centres regarding over the counter homeopathic remedies, conventional medicine and natural medicine. The study used a quantitative approach and self-administered questionnaires. The results reported here are based on 613 valid responses. A binomial test was used to determine the direction of the attitude of the parents with regard to over the counter homeopathic remedies, natural and conventional medicine. Exploratory factor analysis was conducted, using principal component extraction and Varimax rotation, to determine if a meaningful factor structure emerged regarding respondents' attitudes. The factors which could be identified were preference of homeopathic remedies, preference of natural remedies, preference towards treatment from a doctor and respondents against homeopathy. Using Cronbach alpha, the internal consistency for the four factors was tested. In order to determine whether the four identified factor variables would result in a distinct grouping of the respondents, a cluster analysis was performed, using K-means clustering. There was a distinctive grouping of parents regarding their attitude toward these issues. There appears to be an opportunity to actively market natural and over the counter homeopathic products to this market segment.

**JEL classification:** I11, M31

**Keywords:** Over the counter homeopathy, Early childhood development centre, Parental attitude, Market segmentation

### 1. Introduction

Attitude is defined as "a person's enduring favourable or unfavourable evaluations, emotional feelings and action tendencies toward some object or idea" (Kotler & Keller, 2012:190). Evans, Jamal and Foxall (2009:112) note that "some knowledge of an individual's attitude will increase the likelihood of understanding the individual's intended and actual behaviour".

The aim of this article is to report on exploratory research on the attitude of parents with children in early childhood development centres in the Pretoria East area (Gauteng province, South Africa) towards over the counter homeopathic remedies, natural remedies and conventional medicine. Brijball Parumasur and Roberts-Lombard (2012:185) note that research on attitude gives an indication in whether customers have accepted a product. Overall attitude of people on a

---

\* Corresponding author. Address: PO Box 392, UNISA, 0003, South Africa, Tel +27 12 429 4554, E-mail: dsilvn@unisa.ac.za

product or product class is not an automatic guarantee that they will purchase or use these products (Peter & Olson, 2010:143; Schiffman & Kanuk, 2010:247). However, Claudy, Peterson, and O'Driscoll (2013) note that attitude is a key antecedent of consumers' adoption intentions. The results of this research shows that the distinction of those with a positive attitude towards over the counter homeopathic remedies and natural products are users of over the counter homeopathic remedies. Brijball Parumasur and Roberts-Lombard (2012:190) and Moldovan, Goldenberg and Chattopadhyay (2011) note that customers develop a positive attitude towards products that have satisfied their needs, which might lead to positive word-of-mouth. Positive word-of-mouth or recommendation is of importance to the homeopathic and natural remedy industries. The results show that parents who use over the counter homeopathic remedies tried these remedies after a recommendation by someone they trusted, be it a friend, family or colleague. There is a positive influence on word-of-mouth, if the person recommending a product experienced the actual use of the product (Martin & Lueg, 2013; Yang, Hu, Winer, Assael & Chen, 2012; Evans, Jamal & Foxall, 2009:133). This is important for a product such as homeopathic remedies.

A literature review briefly looks at the over the counter homeopathic remedies in South Africa, early childhood development centres, and previous research on attitudes concerning homeopathic remedies, natural remedies, CAM and conventional medicine. This is followed by a discussion on the research methodology, which focused on quantitative research using a survey with a paper-based questionnaire as research instrument. The results concentrate on binomial test results, exploratory factor analysis and cluster analysis. The discussion and conclusions look at the effect of the research results on the homeopathic industry and possible implications to the marketing of over the counter homeopathic remedies.

## **2. Literature review**

### **2.1 Over the counter homeopathy**

Homeopathy is seen as a treatment within the realm of complementary and alternative medicine (CAM). The global CAM market is expected to be worth \$115 billion by 2015 (Global Industry Analysts, 2012). Zuzak et al. (2013) report that there is greater awareness and an increased use of CAM in paediatric health care in Europe, with Längler and Zuzak (2013) reporting that the most often mentioned CAM therapies include homeopathy and acupuncture amongst others. Siponen, Ahonen, Kiviniemi and Hämeen-Anttila (2013) note that parental attitude toward medicines have an impact on how parents medicate their children, especially with CAM. For this reason research on parental attitude towards CAM and specifically over the counter (OTC) homeopathy is of value to the industry.

Consumers can obtain OTC homeopathic remedies without any prescription in South Africa and these remedies are used for various ailments by people from all ages. There are several OTC homeopathic remedies available on the shelves of various South African retailers, be it health stores, pharmacies or pharmacy retailers. Retail shelves are filled with both South African and international OTC homeopathic remedy brands. South African brands include examples such as Natura, Sister Lilian and Pharmanatura and international brands include Boiron, Heel and Similasan, to name a few.

## 2.2 Early childhood development (ECD) centres

An early childhood development (ECD) centre is defined as “any building or premises maintained or used, whether or not for gain, for the admission, protection and temporary or partial care of more than six children away from their parents. Depending on registration, an ECD centre can admit babies (0-18 months), toddlers (18-36 months) and/or pre-school aged children. A pre-school child is a child under six years of age who does not attend formal school. The term ‘ECD centre’ can refer to a crèche, a day-care centre for young children, a playgroup, a pre-school or an after-hours care facility, among other things” (UNICEF & Department of Social Development - South Africa, 2006). Thirty five per cent of children in South Africa aged four years and younger attend ECD centres during the daytime (Statistics South Africa, 2012). The highest attendance occurs in the Gauteng province (43.6%) and the Limpopo province (42%) (Statistics South Africa, 2012). Children attending day-care, such as that of an ECD centre, are sick more often than those who stay at home (Augustine, Crosnoe & Gordon, 2013). This indicates the relevance of the research on parents’ behaviour and attitude toward remedies and treatment of their children’s illnesses and ailments.

## 2.3 Literature on attitudes toward homeopathy, natural remedies and conventional medicine and CAM

Numerous research projects have been dedicated to homeopathy, natural remedies and CAM over the last decade. This section focuses on a glimpse of the research reporting on parental and user attitudes toward homeopathy, natural remedies, CAM and conventional medicine in the last five years. In an attempt provide a concise overview of these articles, Table 1 covers aspects including the occurrence of CAM; the reasons for the increased use of CAM; the attitudes toward CAM, homeopathy, natural remedies and attitudes toward conventional medicine. The outcomes of the various research projects conducted in different countries and the first listed author of each project is given in the table.

Table 1: Summary of literature on homeopathy, natural remedies, CAM and conventional medicine

<b>The occurrence of CAM</b>		
<b>Topic</b>	<b>Countries</b>	<b>Reference (first authors only)</b>
Increased and current use of CAM in children	Europe,	Zuzak (2013) Längler (2013)
	USA, International, Canada, UK, Israel, Korea, Germany, Turkey, Australia	Bell(2013) Italia (2014) Pike (2013) Posadzki (2013) Gruber (2014) Kim (2012) Du (2014) Araz (2011) Wadhera (2011)



Homeopathy is among the top five CAM modalities used	Israel, UK, Italy, International, Europe, Germany, Netherlands	Gruber (2014) Posadzki (2013) Barbadoro (2011) Italia (2014) Längler (2013) Gottschling (2013) Singendonk (2013)
Herbal remedies is among the top five CAM modalities used	UK, Canada, Italy, International, Kuwait, Germany	Posadzki (2013) Pike (2013) Barbadoro (2011) Italia (2014) Awad (2014) Gottschling (2013)
<b>Reasons for the increased use of CAM</b>		
<b>Topic</b>	<b>Countries</b>	<b>Reference (first authors only)</b>
Lack of trust in a physician	Israel	Gruber (2014)
Conventional medicine failed as a solution for a particular illness or ailment	Israel, USA	Gruber (2014) McFadden (2010) Bell (2013)
Recommendation or advice was given by family and friends	Kuwait, Canada, Turkey, Australia	Awad (2014) Pike (2013) Araz (2011) Wadhera (2011)
Users of CAM have higher education levels	Finland,  Italy, International, Serbia, Korea, Turkey, Germany	Hämeen-Anttila (2011) Siponen (2013) Barbadoro (2011) Italia (2014) Samojlik (2013) Kim (2012) Araz (2011) Du (2014)
<b>Attitudes toward CAM, homeopathy and natural remedies</b>		
<b>Topic</b>	<b>Countries</b>	<b>Reference (first authors only)</b>
Holistic view toward health	USA, International	McFadden (2010) Italia (2014)
Use of more natural solutions with the belief of fewer side effects	Israel, RSA, Canada, USA, Germany	Gruber (2014) Du Plessis (2012) Pike (2013) Bell (2013) Du (2014)

Taking control of personal health and family health	USA, Ireland, Finland, Kuwait, Germany	McFadden (2010) Hanna (2011) Siponen (2013) Awad (2014) Gottschling (2013)
Positive attitude/satisfaction towards CAM and natural remedies	RSA, Canada, UK, Italy, Finland, Kuwait, Korea, Netherlands, Australia	Du Plessis (2012) Pike (2013) Hanna (2011) Barbadoro (2011) Siponen (2013) Awad (2014) Kim (2012) Singendonk (2013) Wadhera (2011)
CAM should be used in an integrative and complementary fashion to conventional medicine	UK, Kuwait, Israel, Netherlands, Germany, Australia	Hanna (2013) Awad (2014) Ben-Arye (2011) Jong (2012a) Gottschling (2013) Wadhera (2011)
<b>Attitudes toward conventional medicine</b>		
<b>Topic</b>	<b>Countries</b>	<b>Reference (first authors only)</b>
Evidence and effectiveness of medication is important	Ireland, UK	Hanna (2011) Hanna (2013)
Parents/users are concerned regarding medication side effects, safety and risks	Finland,  Canada, USA, Ireland	Hämeen-Anttila (2011) Siponen (2013) Pike (2013) Bell (2013) Hanna (2011)
Positive attitude on OTC medication leads to a positive attitude towards CAM	Finland	Siponen (2013)
People with young children purchased more OTC medication than those without	Ireland	Hanna (2011)

From the literature summary in Table 1 several aspects can be gathered. An important aspect most pertinent to this study is that the use of CAM is on the increase internationally, in varying degrees. Homeopathy and herbal remedies are among the top five CAM modalities worldwide. The reasons for the increase in CAM include the failure of conventional medicine to treat particular illnesses and ailments, the recommendation from friends and family rather than health professionals, as well as the increased levels of education of parents. From the attitudes toward CAM, homeopathy and natural medicines and remedies, it appears that users and parents prefer to have a more holistic health approach

looking for natural solutions, which to their belief, has fewer side effects. There is an increased feeling of control of personal and family health and a general positive attitude and feeling of satisfaction toward CAM, which includes homeopathy and natural remedies. From the literature it would seem that there is a keen interest among users to have CAM, including homeopathy and natural remedies, integrated into conventional medicine.

On searching for the attitudes people have toward conventional medicine, there is not such an influx of information within the last couple of years. However, certain concerns were raised in research pertaining to conventional medication, as seen in Table 1. Evidence regarding the effectiveness of medication has become important, together with concerns regarding the safety, side effects and risks associated with conventional medication, especially in paediatric use. When looking at the attitudes people have toward over the counter (OTC) conventional medication, there is a positive relationship between the attitudes people have toward OTC conventional medication and their positive attitudes toward CAM (Siponen et al., 2013). Furthermore, people with young children purchase more OTC conventional medication than those who do not have children (Hanna & Hughes, 2011).

This article reports on research that sought to explore the attitude of parents with children in early childhood development centres towards over the counter homeopathic remedies, natural and conventional medicine.

### **3. Research method**

In the research that was conducted, quantitative research techniques were applied, a survey was used with a self-administered paper-based questionnaire as the research instrument.

Attitude can be measured using either the semantic differential scale or Likert scales (Evans et al., 2009:109). Likert scales, also known as summated-ratings scales, were used in the research. It is the most widely-used, attitude-scaling technique in marketing research. For the purpose of this article, it was decided to use a 6-point Likert-response format instead of the traditional 5-point Likert-response format. The reason was to have respondents commit to either a positive or a negative end to the scale without the use of a neutral option. This relates to the positive or negative nature of attitude as previously mentioned.

The population for this research comprised parents with children in ECD centres in the Pretoria East area. The telephone directory was manually scanned to find all the possible ECD centres in the Pretoria East area. The various ECD centres which could be identified for the entire municipal area were cross-checked with the municipal map of Region 6, which as per the local government, constitutes the Pretoria East area. The number of ECD centres in the Pretoria East area, which had contact details listed in the telephone directory, directly resulted in 51 ECD centres. A census approach was used; all the centres were contacted to obtain permission to conduct research. Questionnaires were sent to all respondents of all the ECD centres that had given permission for research to be conducted. A total of 3 070 questionnaires were distributed to all 25 ECD centres that had given permission for research to be conducted. The number of returned questionnaires was 665, which indicated a response rate of 21.66%. The number of usable questionnaires with valid responses was 613, with a revised response rate of 19.97%. The discussion and results related to the 613 valid responses follow in the next section.

#### 4. Empirical Analysis

A binomial test was used to determine the direction of the attitude of the parents with regard to over the counter homeopathic remedies, natural and conventional medicine.

In order to get either a positive or negative perspective on these aspects, responses of respondents had to be transformed into two categories. Responses which are considered positive, included 'Somewhat agree', 'Agree' and 'Strongly agree', coded as 4, 5 and 6 respectively, were grouped together and coded as a 2 (labelled 'Category 2'). Responses that could be considered negative included 'Strongly disagree', 'Disagree' and 'Somewhat disagree,' coded as 1, 2 and 3, were grouped together and coded as a 1 (labelled 'Category 1'). The results of the binomial test are given in Table 2 to Table 4 below.

The hypotheses tested are:

H0:  $p = 0.5$  (The proportion of respondents that have a positive perspective is equal to 0.5)

H1:  $p \neq 0.5$  (The proportion of respondents that have a positive perspective is not equal to 0.5)

Table 2: Respondent attitude on homeopathic remedies in comparison to conventional medicine

Hypothesis	Category	N	Observed Prop.	Test Prop.	Exact Sig. (2-tailed)
I use homeopathic remedies before conventional medicine	1.00	377	0.63	0.50	0.000
	2.00	222	0.37		
		599	1.00		
I believe homeopathy is equal to conventional medicine	1.00	375	0.63	0.50	0.000
	2.00	220	0.37		
		595	1.00		
I use OTC homeopathic remedies as alternative medicine	1.00	449	0.74	0.50	0.000
	2.00	156	0.26		
		605	1.00		
I use OTC homeopathic remedies as complementary medicine	1.00	279	0.46	0.50	0.061
	2.00	326	0.54		
		605	1.00		
Homeopathy has no place in medicine	1.00	547	0.91	0.50	0.000
	2.00	52	0.09		
		599	1.00		

All statements were statistical significant except for the statement "I use OTC homeopathic remedies as complementary medicine" at the 1% level of significance and the null hypotheses can be rejected for these statements. From the respondents' reaction to the statements, it can be gathered that parents do not use homeopathic

remedies before conventional medicine, and do not view homeopathic remedies as quite on a par with conventional medicine. Parents also do not use OTC homeopathic remedies as an alternative treatment to conventional medicine. Respondents do not perceive homeopathy as something to be avoided entirely.

An almost equal proportion of parents agreed and disagreed with the statement regarding the use of homeopathic remedies as complementary medicine to conventional medicine (0.46 and 0.54).

Table 3: Respondent attitude towards natural remedies

Hypothesis	Category	N	Observed Prop.	Test Prop.	Exact Sig. (2-tailed)
I think doctors today need more training in homeopathy and other natural remedies	2.00	532	0.88	0.50	.000
	1.00	74	0.12		
		606	1.00		
I think natural remedies are the way of the future	2.00	451	0.75	0.50	.000
	1.00	153	0.25		
		604	1.00		
I think more should be done to integrate natural remedies with conventional medicine	2.00	544	0.90	0.50	.000
	1.00	62	0.10		
		606	1.00		
I need to have scientific proof that medicine works before I will try it	1.00	184	0.30	0.50	.000
	2.00	421	0.70		
		605	1.00		
I do not believe in natural remedies for my family	1.00	524	0.87	0.50	.000
	2.00	80	0.13		
		604	1.00		

From the subsection on the opinions and attitude of respondents towards natural remedies, it could be gathered that respondents tend to agree more with the following statements (the proportion of 'positive responses' is given in brackets):

- I think doctors today need more training in homeopathy and other natural remedies (0.88).
- I think natural remedies are the way of the future (0.75).
- I think more should be done to integrate natural remedies with conventional medicine (0.90).
- I need to have scientific proof that medicine works before I will try it (0.70).

Respondents tend to disagree more with the following statements (the proportion of 'negative responses' is given in brackets): I do not believe in natural remedies for my family (0.87).

Table 4: When respondents deem it necessary to have their children treated by a doctor or emergency room

Hypothesis	Category	N	Observed Prop.	Test Prop.	Exact Sig. (2-tailed)
If my child has a fever, no matter what the thermometer reading is, we go to the doctor	1.00	504	0.83	0.50	0.000
	2.00	101 605	0.17 1.00		
I will call a doctor or emergency room when my child has a fever higher than 35 degrees Celsius	2.00	390	0.65	0.50	0.000
	1.00	212 602	0.35 1.00		
I will call a doctor or emergency room at the first sign of illness of my children	1.00	501	0.83	0.50	0.000
	2.00	102 603	0.17 1.00		
Only after I have done everything I know or have read up on, will I take my child to a doctor	1.00	124	0.21	0.50	0.000
	2.00	479 603	0.79 1.00		
When I deal with something strange, I have not dealt with before (such as a strange rash or strange cough), we go to the doctor	2.00	532	0.88	0.50	0.000
	1.00	75 607	0.12 1.00		
I feel I do not know enough about medicine and would rather consult a doctor for all ailments and illnesses	2.00	268	0.44	0.50	0.006
	1.00	336 604	0.56 1.00		
I do not have the time to search for information about my children's illnesses and ailments, hence we go to a doctor	2.00	175	0.29	0.50	0.000
	1.00	429 604	0.71 1.00		

The last subsection dealt with when parents find it prudent to have their children treated by a doctor or emergency room. Respondents tended to agree more with the following statements (the proportion of 'positive responses' is given in brackets):

- I will call a doctor or emergency room when my child has a fever higher than 38.5 degrees Celsius (0.65).
- Only after I have done everything I know or have read up on, will I take my child to a doctor (0.79).
- When I deal with something I have not dealt with before (such as a strange rash or strange cough), we go to the doctor (0.88).

Respondents tended to disagree more with the following statements (the proportion of 'negative responses' is given in brackets):

- If my child has a fever, no matter what the thermometer reading is, we go to the doctor (0.83).
- I will call a doctor or emergency room at the first sign of illness of my children (0.83).
- I feel I do not know enough about medicine and would rather consult a doctor for all my children's ailments and illnesses (0.56).
- I do not have the time to search for information about my children's illnesses and ailments; hence we go to a doctor (0.71).

#### 4.1 Exploratory factor analysis

Exploratory factor analysis was conducted, using principal component extraction and Varimax rotation, to determine if a meaningful factor structure emerged regarding respondents' attitudes of homeopathy, natural remedies and conventional medicine. To determine whether the data was suitable for a factor analysis, a Bartlett's test of sphericity and the Keiser-Meyer-Olkin (KMO) measure of sampling adequacy were conducted. Bartlett's test of sphericity was significant ( $p= 0.000$ ) and the KMO value was 0.827, which indicated that it was feasible to conduct factor analysis on the captured data.

The data were subjected to principal component analysis with factors with eigenvalues greater than 1.0 to be considered. Varimax rotation was applied in order to minimise the number of variables that had high loadings on any factor and to improve the degree to which the factors correlated and for ease of interpretation. Four factors, based on the rotated factor loadings and scree plot, were extracted, accounting for 42.7% of the variance. Using Cronbach alpha, the internal consistency (reliability) for the four factors was found to be 0.779, 0.837, 0.774 and 0.831, which are all above the recommended threshold value of 0.7 and are thus considered to be satisfactory.

The rotated factor loadings, eigenvalues, percentage variance explained by the factor, the Cronbach alpha value (reliability) for the factor and the mean value for each factor are shown in Table 5 below.

Table 5: Factor analysis results

Factor descriptors	Factor loadings	Eigen value	Variance (%)	Cronbach Alpha ( $\alpha$ )	Mean
<b>Factor 1: Homeopathy preference</b>		6.126	20.421	0.779	2.876
I use homeopathic remedies before using conventional medicine	0.833				
I believe homeopathy is equal to conventional medicine	0.614				
I use OTC homeopathic remedies	0.826				

Factor descriptors	Factor loadings	Eigen value	Variance (%)	Cronbach Alpha ( $\alpha$ )	Mean
as alternative medicine					
<b>Factor 2: Natural remedies preference</b>		3.019	10.063	0.837	4.524
I think doctors today need more training in homeopathy and other natural remedies	0.762				
I think natural remedies are the way of the future	0.761				
I think more should be done to integrate natural remedies with conventional medicine.	0.813				
<b>Factor 3: Prefer doctor's help</b>		2.083	6.943	0.774	3.046
If my child has a fever, no matter what the thermometer reading is, we go to the doctor	0.830				
I will call a doctor or emergency room when my child has a fever higher than 38.5 degrees Celsius	0.719				
I will call a doctor or emergency room at the first sign of illness of my children	0.777				
I feel I do not know enough about medicine and would rather consult my doctor for all my children's ailments and illness	0.607				
<b>Factor 4: Against homeopathy</b>		1.581	5.268	0.831	1.915
Homeopathy has no place in medicine	0.727				
Homeopathy is dangerous and should be avoided at all costs	0.788				



Factor 1, which is labelled as 'Homeopathy preference', was concerned with the degree to which the respondents preferred homeopathy. This factor comprised of three items that explained 20.42% of the total variance. The mean value of 2.876 indicates that respondents tended, on average, to vary their opinion regarding a preference for homeopathy towards 'Somewhat disagree'. This result corresponds with the Binomial test results.

Factor 2, which is labelled 'Natural remedies preference', was concerned with the degree to which parents preferred natural remedies. This factor comprised of three items that explained 10.06% of the total variance. The mean value of 4.524 implies that the respondents, on average, tended to 'somewhat agree and agree' that they preferred natural remedies.

Factor 3, labelled as 'Prefer doctor's help', was concerned with the degree to which the respondents preferred to obtain the services of a health professional, especially that of a doctor or emergency room. This factor comprised of four items that explained 6.94% of the total variance. The mean value of 3.046 indicates that respondents tended, on average, to 'somewhat disagree' with the notion that their first port of call regarding their children's ailments and illnesses is to make use of the services of a health professional (e.g. a doctor or emergency room).

Factor 4, which is labelled 'Against homeopathy', was concerned with the degree to which the respondents' opinion is against homeopathy. This factor was comprised of items that explained 5.268% of the total variance. The mean value is 1.915 which indicates that parents on average tended to 'disagree and strongly disagree' that homeopathy should be avoided.

## 4.2 Cluster analysis

In order to determine whether the four identified factor variables would result in a distinct grouping of the respondents, a cluster analysis was performed.

K-means clustering was used, which requires the number of clusters to be specified in advance. Two clusters were chosen for this study. One cluster looked at the users of OTC homeopathic remedies and the other cluster included the non-users of these remedies. Fifty five per cent of respondents (334 out of 613 valid responses) indicated that they use OTC homeopathic remedies and 46% (279 out of 613 valid responses) do not.

The output is shown in Tables 6 and 7. The four variables 'prefer homeopathy', 'natural remedies', 'prefer doctor's help' and 'Against homeopathy' refer to Factors 1 to 4 previously identified in the factor analysis.

Table 6: Final cluster centres

	Cluster	
	Users of OTC homeopathic remedies	Non-users of OTC homeopathic remedies
Prefer homeopathy	3.70	1.99
Natural remedies	5.06	3.93
Prefer doctor's help	2.83	3.23
Against homeopathy	1.38	2.49

Table 7: Number of cases in each cluster

Cluster:	Prefer homeopathy and natural remedies	311
	Prefer conventional medicine	289
	Valid	600
	Missing	46

As a result of the cluster centre pattern, the individuals in cluster 1 (the users of OTC homeopathic remedies) can be described as those who have a tendency towards 'Prefer homeopathy and natural remedies' while those in cluster 2 (the non-users of OTC homeopathic remedies) are those that tend more towards conventional medicine. It is interesting to note that the proportion of individuals in each cluster was almost equal, with a slightly higher proportion in the 'Prefer homeopathy and natural remedies' group.

On a question whether OTC homeopathic remedy users started using these remedies as a result of a recommendation from someone they trusted, 217 of 325 respondents who answered the question, agreed that that was the case while 108 did not agree. The discussion and conclusions regarding these results are discussed in the next section.

## 5. Discussion and conclusions

The aim of the research was to explore the attitude of parents regarding over the counter homeopathic remedies, natural and conventional medicine. From the results of the binomial tests and the factor analysis it can be gathered that parents do not consult a doctor or emergency room for all their children's ailments and illnesses or at the first sign of illness. Parents only deem a doctor's visit necessary once they feel they have done everything they possibly can. Parents do not only use prescribed medicine, which indicated a strong possibility of over the counter medication being used, whether homeopathic, natural or otherwise. This links strongly with the literature as given in Table 1 and discussed by Hanna and Hughes (2011), that people with young children purchase more OTC medication than those who do not have children. An issue which might strongly influence the use of over the counter medication is the increasing cost of medicines in South Africa. The effect of the cost of medicine on the use of OTC medication, whether homeopathic or conventional, is a suggestion for further research. The results indicate that parents do not feel that homeopathy is dangerous or should be avoided entirely. As seen in Table 1, homeopathic and herbal remedies are among the top five CAM modalities worldwide. This indicates a strong opportunity for the South African homeopathic industry to provide parents with comprehensive information regarding over the counter homeopathic remedies.

Parents seem to want a more integrated approach between conventional medicine and natural remedies to treat their children's common health problems. As seen in Table 1, this seems to be a notion internationally. A suggestion is that the training of physicians should incorporate the use of natural remedies. Not only do parents feel that an integrative approach between conventional and natural medicine is necessary, but it is also viewed as a definite need or future prerequisite of parents to have doctors trained in natural options. Parents view homeopathic

remedies as a complementary means of treatment rather than alternative. Parents trust their doctors to have their best medical intentions at heart and to prescribe the appropriate medication for illnesses and ailments, which includes the sphere of natural remedies. This ties in strongly with Jong, van de Vijver, Busch, Fritsma and Seldenrijk (2012) that people wish to have integrated medical care between CAM and conventional medicine.

Parents indicated that they require scientific proof that medication is effective before they will try it. This is true for both homeopathic and conventional medicine. The latter rings true, especially regarding conventional paediatric medication as seen in the literature summary in Table 1, and discussed by Hanna and Hughes (2011). Parents do not view homeopathy as being on a par with conventional medicine. This factor could possibly indicate that there is a gap between the perception parents have of homeopathy and the available information. An opportunity exists for the numerous peer-reviewed, industry-related and relevant research proving the efficacy of homeopathic remedies, to be made known in the media that parents use in their information search. Parents could simply not be aware of proof of efficacy based on scientific research.

Malhotra (2010:663) notes that cluster analysis can be used for several marketing purposes, including understanding buyer behaviour. The cluster analysis shows that there is a clear clustering or grouping among parents towards those who prefer to use natural medicine and homeopathy and have a positive attitude towards these remedies and those who prefer and use conventional medicine. Brijball Parumasur and Roberts-Lombard (2012:185) note that customers develop positive attitudes towards products that have satisfied their needs. In comparison to the literature summary in Table 1, this cluster shows a definite link to international users of CAM, which includes homeopathic and natural remedies. From the literature it can be seen that people who use CAM prefer a more holistic health approach looking for natural solutions to illnesses and ailments. There is also a strong link to the satisfaction people experience from using CAM and the positive attitude people have internationally toward CAM. The clear clustering of users with a positive attitude toward natural medicine and OTC homeopathy is a good indication of a market segment which needs nurturing and specialised marketing efforts. A large number of parents indicated that they initially tried these remedies as a result of a recommendation by someone they trusted, be it a friend, colleague or family. The recommendation of family and friends is a definite and strong consideration in the decision-making of parents, when looking for natural health solutions, as seen in the literature and results of this study. Mothers with small children tend to have an extensive social network (Iyengar, Van den Bulte, Eichert, West & Valente, 2011). The use of opinion leaders and positive word of mouth should not be underestimated as parents, and particularly mothers, looking for natural health alternatives will turn to their social and reference networks for recommendations. Further research should be conducted to determine how the use of opinion leaders can be applied by the homeopathic industry in their marketing efforts.

The results of this study are limited to the Pretoria East area and cannot be generalised to the greater South Africa. Another limitation is the possibility of non-response bias, from parents and schools, which did not participate in the study. To get a better idea of the attitude parents with children in ECD centres in other areas

of South Africa have towards OTC homeopathic remedies, it is required to conduct further research in areas with similar demographics. Further research is required to understand the decision making of parents using OTC homeopathic remedies and other deciding factors. It goes without saying that parents with children in ECD centres is a niche market segment for the OTC homeopathic industry. However, due to the regular occurrence of common illnesses among children attending these centres, repeat purchases from satisfied customers is likely to occur, as result of the positive attitude parents have toward natural and homeopathic remedies.

## References

- Araz, N., Bulbul, S. (2011), Use of complementary and alternative medicine in a pediatric population in southern Turkey. *Clinical and Investigative Medicine*, 34(1), 21–29.
- Augustine, J. M., Crosnoe, R. L., Gordon, R. (2013), Early child care and illness among preschoolers. *Journal of Health and Social Behavior*, 54(3), 315–34.
- Awad, A., Al-shaye, D. (2014), Public awareness, patterns of use and attitudes toward natural health products in Kuwait: a cross-sectional survey. *BMC Complementary and Alternative Medicine*, 14(1), 1–11.
- Barbadoro, P., Chiatti, C., D'Errico, M. M., Minelli, A., Pennacchiotti, L., et al. (2011), Complementary and Alternative Medicine (CAM) among adults in Italy: Use and related satisfaction. *European Journal of Integrative Medicine*, 3(4), e325–e332.
- Bell, I.R., Boyer, N.N. (2013), Homeopathic Medications as Clinical Alternatives for Symptomatic Care of Acute Otitis Media and Upper Respiratory Infections in Children. *Global advances in health and medicine: improving healthcare outcomes worldwide*, 2(1), 32–43.
- Ben-Arye, E., Traube, Z., Schachter, L., Haimi, M., Levy, M. (2011), Integrative Pediatric Care: Parents' Attitudes Toward Communication of Physicians and CAM Practitioners. *Pediatrics*, 127(1), e84-95.
- Brijball Parumasur, S., Roberts-Lombard, M. (Eds.) (2012), *Consumer Behaviour* (2nd ed.). Cape Town: Juta.
- Claudy, M.C., Peterson, M., O'Driscoll, A. (2013), Understanding the Attitude-Behavior Gap for Renewable Energy Systems Using Behavioral Reasoning Theory. *Journal of Macromarketing*, 33(4), 273–287.
- Du Plessis, S. (2012), *A Survey to Determine the Attitudes Towards Complementary and Alternative Medicine by Users in Cape Town*. University of Johannesburg.
- Du, Y., Wolf, I., Zhuang, W., Bodemann, S., Knöss, W., & Knopf, H. (2014), Use of herbal medicinal products among children and adolescents in Germany. *BMC Complementary And Alternative Medicine*, 14, 218.
- Evans, M., Jamal, A., Foxall, G. (2009), *Consumer Behaviour* (2nd ed.). West Sussex: John Wiley and Sons.
- Global Industry Analysts. (2012), *Global Alternative Medicine Industry*.
- Gottschling, S., Gronwald, B., Schmitt, S., Schmitt, C., Längler, A. (2013), Use of complementary and alternative medicine in healthy children and children with chronic medical conditions in Germany. *Complementary Therapies in Medicine*, 21 Suppl 1, S61–9.

- Gruber, M., Ben-Arye, E., Kerem, N., Cohen-Kerem, R. (2014), Use of complementary alternative medicine in pediatric otolaryngology patients: a survey. *International Journal of Pediatric Otorhinolaryngology*, 78(2), 248–52.
- Hämeen-Anttila, K., Halonen, P., Siponen, S., Holappa, M., Ahonen, R. (2011), Parental attitudes toward medicine use in children in Finland. *International Journal of Clinical Pharmacy*, 33(5), 849–58.
- Hanna, L.-A., Hall, M., McKibbin, K. (2013), Pharmacy students' knowledge, attitudes, and use of complementary and alternative medicines. *Currents in Pharmacy Teaching and Learning*, 5(6), 518–525.
- Hanna, L.-A., Hughes, C. M. (2011), Public's views on making decisions about over-the-counter medication and their attitudes towards evidence of effectiveness: a cross-sectional questionnaire study. *Patient Education and Counseling*, 83(3), 345–51.
- Italia, S., Wolfenstetter, S.B., Teuner, C.M. (2014), Patterns of Complementary and Alternative Medicine (CAM) use in children: a systematic review. *European Journal of Pediatrics*.
- Iyengar R, Van den Bulte C, Eichert J, West B, Valente T.W. (2011), How social networks and opinion leaders affect the adoption of new products. *GfK Marketing Intelligence Review*, 3(1), 16–25.
- Jong, M. C., van Vliet, M., Huttenhuis, S., van der Veer, D., van den Heijkant, S. (2012a), Attitudes toward integrative paediatrics: a national survey among youth health care physicians in the Netherlands. *BMC Complementary and Alternative Medicine*, 12(1), 4.
- Jong, M.C., van de Vijver, L., Busch, M., Fritsma, J., Seldenrijk, R. (2012), Integration of complementary and alternative medicine in primary care: what do patients want? *Patient education and counseling*, 89(3), 417–22.
- Kim, J., Nam, C., Kim, M., Lee, D. (2012), The use of complementary and alternative medicine (CAM) in children: a telephone-based survey in Korea. *BMC Complementary and Alternative Medicine*, 12(1), 1.
- Kotler, P., Keller, K. (2012), *Marketing Management* (14th ed.). New Jersey: Pearson/Prentice Hall.
- Längler, A., Zuzak, T.J. (2013), Complementary and alternative medicine in paediatrics in daily practice - A European perspective. *Complementary Therapies in Medicine*, 21 Suppl 1, S26–33.
- Malhotra, N. (2010), *Marketing Research An Applied Orientation* (6th ed.). New Jersey: Pearson.
- Martin, W.C., Lueg, J.E. (2013), Modeling word-of-mouth usage. *Journal of Business Research*, 66(7), 801–808.
- McFadden, K.L., Hernández, T.D., Ito, T.A.A. (2010), Attitudes toward complementary and alternative medicine influence its use. *Explore (New York, N.Y.)*, 6(6), 380–8.
- Moldovan, S., Goldenberg, J., Chattopadhyay, A. (2011), The different roles of product originality and usefulness in generating word-of-mouth. *International Journal of Research in Marketing*, 28(2), 109–119.
- Peter, J., Olson, J. (2010), *Consumer Behavior & Marketing Strategy* (Ninth.). New York: McGraw-Hill Irwin.

- Pike, A., Etchegary, H., Godwin, M., McCrate, F., Crellin, J.(2013), Use of natural health products in children Recherche Utilisation de produits de santé naturels chez l'enfant. *Canadian Family Physician*, 59, e372–8.
- Posadzki, P., Watson, L., Alotaibi, A., Ernst, E. (2013), Prevalence of complementary and alternative medicine (CAM)-use in UK paediatric patients: a systematic review of surveys. *Complementary Therapies in Medicine*, 21(3), 224–31.
- Samojlik, I., Mijatović, V., Gavarić, N., Krstin, S., Božin, B. (2013), Consumers ' attitude towards the use and safety of herbal medicines and herbal dietary supplements in Serbia. *International Journal of Clinical Pharmacy*, 35, 835–840.
- Schiffman L.G., Kanuk, L. (2010), *Consumer Behavior* (10th ed.). New Jersey: Pearson/Prentice Hall.
- Singendonk, M., Kaspers, G., Naafs-Wilstra, M. (2013), High prevalence of complementary and alternative medicine use in the Dutch pediatric oncology population: a multicenter survey. *European Journal of Pediatrics*,172(1) 31–37.
- Siponen, S., Ahonen, R., Kiviniemi, V., Hämeen-Anttila, K. (2013), Association between parental attitudes and self-medication of their children. *International Journal of Clinical Pharmacy*, 35(1), 113–20.
- Statistics South Africa (2012), *Statistical release*. Retrieved on 10 July 2014 from <https://www.statssa.gov.za/publications/P0318/P0318April2012.pdf>
- UNICEF, & Department of Social Development - South Africa (2006), Guidelines for Early Childhood Development Services. Retrieved on 10 April 2013 from [www.unicef.org/southafrica/resources\\_3446.html](http://www.unicef.org/southafrica/resources_3446.html)
- Wadhera, V., Lemberg, D.A., Leach, S.T., Day, A.S. (2011), Complementary and alternative medicine in children attending gastroenterology clinics: Usage patterns and reasons for use. *Journal of Paediatrics and Child Health*, 47(12), 904–910.
- Yang, S., Hu, M., Winer, R., Assael, H., Chen, X. (2012), An Empirical Study of Word-of-Mouth Generation and Consumption. *Marketing Science*, 31(6), 952–963.
- Zuzak, T.J., Boňková, J., Careddu, D., Garami, M., Hadjipanayis, A. (2013), Use of complementary and alternative medicine by children in Europe: published data and expert perspectives. *Complementary Therapies in Medicine*, 21 Suppl 1, S34–47.

## FROM SUSTAINABILITY TO INTEGRATED REPORTING – THE POLITICAL PERSPECTIVE OF INSTITUTIONAL THEORY

**Adriana TUDOR-TIRON**

Babeș-Bolyai University, Romania

**Ioana DRAGU\***

Babeș-Bolyai University, Romania

**Abstract.** In a world dominated by extreme business competition, corporations start to reconsider their strategies and concentrate more on their stakeholders. In order to sustain the non-financial initiatives of the business environment the International Integrated Reporting Committee initiates integrated reporting to interrelate financial and non-financial information. The diffusion and adoption of integrated reports precedes theory and emerges from corporate reporting practice. However, the diffusion of IR did not occur proportionally, thus differing according to region/country. The purpose of this paper is to present the adoption of integrated reporting from an institutional perspective by analyzing the influence of the legal origin of countries whose companies report in an integrated manner. Our methodology assumes the computation of a disclosure index for each company/report for which we performed an analysis on the regional concentration of the integrated reporting formation. Finally, we compare the results of the civil law versus common law countries according to the values of the disclosure index. The findings suggest that IR disclosure level is higher in common law countries than in civil law countries. The current paper aims to bring a contribution into the corporate reporting literature by adding knowledge for a newly developed research topic- integrated reporting.

**JEL classification:** M4

**Keywords:** sustainability, integrated reporting, institutional theory, political factors

### 1. Introduction

Integrated reporting derives from sustainability information, as a result of financial and non-financial performance at all levels. The first non-financial initiatives from the corporate environment were the corporate responsibility or environmental reports presented as separate documents from the annual financial report. The novelty of integrated reporting results from commitment to the environment, social recognition, as sustainability and CSR- Corporate Social Responsibility information is integrated in the annual report. Organizations that issue integrated reports are guided by the *principles and content elements* of the IIRC on integrated reporting.

---

\* Corresponding author. Address: Teodor Mihali, Cluj Napoca, Tel 0740037759, E-mail: ioanadragu@yahoo.com

We argue that the *political* pressure influences the disclosure of integrated reports, according to institutional theory. The influence of the politics upon regulation and practice is broadly discussed by many scholars and academics (Bushman and Piotroski, 2006; Rugman, 2000; Ferner, 1997; Jensen & Berg, 2011). We consider that the political system determines the level of integrated reporting information.

Our research question can be stated as follows:

- Is the *country legal system* a determinant for *integrated reporting*?

The classification of countries' legal system in *common and civil law* is made in accordance with La Porta et al (1998). The same reference is used in the paper issued by Jensen & Berg (2011). In order to validate a report as having the characteristics of an *integrated* one, we made a checklist based on the *IIRC principles and content elements*.

Jensen & Berg (2011) note countries with a civil law political system have an extended approach towards stakeholders and social- environmental is highly appreciated (Kolk and Perego, 2010; Kolk et al.,2001). On the other hand, the common law system is much more shareholder oriented (Kolk and Perego, 2010; Ball et al., 2000; La Porta et al., 1998).

Although we can identify various literature sources regarding the political influence on corporate reporting, this is the first study that uses a specific scale for measuring integrated reporting – the IIRC principles and content elements and thus correlated the quality of integrated reports/ degree of integrated reporting with the country legal system. We consider that one of the main research gaps in integrated reporting is the lack of instruments to measure *integration* and the need to establish some important determinants for the preparation of integrated reports.

## **2. Methodology**

In order to answer to the above question, we employ in a methodology that involves more stages, namely: [1] archival research, [2] content analysis, and [3] empirical study of disclosures level for integrated reports from the political perspective of country legal origin.

We start by discussing the most relevant integrated reporting initiatives mentioned in the sustainability literature. Actually employing in an intense archival research, our main purpose is to capture the imposition and role of different states in the development of integrated reports. As shown by various empirical and theoretical studies, integrated reporting (IR) originates from sustainability. In addition, we claim that those countries that enrolled in legal initiatives for pursuing sustainability reporting and practice or have become a proper environment for organizations that adopted IR are also subject to high quality disclosure from an IR perspective. We intend to compare our presumptions from the reviewed literature with the presumptions of institutional theory and legal origin, and ultimately the findings of our empirical study.

The content analysis explores the annual integrated reports for years 2010-2012. We checked against each report the noted elements for IR as stated by the IIRC, namely: *strategic focus; connectivity of information; future orientation; responsiveness and stakeholder inclusiveness; conciseness, reliability and materiality; organizational*



*overview and business model; operating context, including risks and opportunities; strategic objectives and strategies to achieve those objectives; governance and remuneration; performance; future outlook.*

The next stage was to perform the final analysis by computing the disclosure index for the guiding principles and content elements of IR. Each one of the noted elements has been attributed the same proportion, so that the score fluctuates from “1” to “0”, depending if the element has been disclosed or not. We then ranked the disclosure level in an attempt to explain the differentiated IR disclosure through the political perspective- country legal origin:

$$DI_{IR} = \sum(d, \text{effectively disclosed}) / \sum(d, \text{all possible cases of disclosure})$$

The disclosure index has been used in quantitative research that involves content analysis. Academics and scholars developed empirical studies and regressions in which they measure the effect of certain variables such as size, industry, political factors (civil/ common law), cultural factors, economic development, sales, profitability rates, etc. on different types of disclosure: mandatory vs. voluntary; financial vs. social, environmental: Stanga, 1976; Prencipe, 2004; Chen and Jagg, 2000; Gray et al., 2001.

### **Research primary data**

The research assumes a sample of estimated 35 companies that adopted integrated reporting. The analysis of their integrated annual reports will be conducted for two years 2009-2012, as first integrated reports were published for 2009. The sample comprises 58 companies that operate in 19 countries (see Appendix 1). The firms from our sample have also been classified by industry type: services, industrials, utilities, basic materials, healthcare, consumer goods, technology, oil and gas, telecommunications. The companies have been selected from the online IIRC database that contains examples of integrated reports.

### **3. Literature Review**

Initiatives for issuing non-financial reporting regulations were conducted by certain influential countries or organizations, as well as international stock exchanges (ACCA, 2011). France, United States, Denmark and Sweden played an active role in implementing requirements for extra financial information. The Nouvelles Régulations Economiques, issued by France, established a framework for sustainability disclosure with respect to “corporate governance, social and community impacts, environmental management, and workplace practices” (p. 12). In 2002, the US regulates disclosure of corporate governance, code of conduct, and environmental information, through the Sarbanes–Oxley Act. The Danish Financial Statements Act enforced by Denmark states the main requirements for sustainability reporting. In Sweden, public companies are requested to disclose on sustainability and assurance for this type of non-financial information. The European Alliance for Corporate Social Responsibility has been set up in year 2006 at the initiatives of the European Commission and European business community, and since then promotes corporate social responsibility and social-environmental integration. Four international stock exchanges (TMX Group, NYSE Euronext, BM & FBOVESPA, Bourse de Luxembourg demand for reporting on

sustainability indices. The Johannesburg Stock Exchange claims that listed companies have to fully report on their non-financial information that becomes mandatory. Similar requirements are issued by Bursa Malaysia that adds corporate social responsibility practice and assurance. Singapore Stock Exchange promotes voluntary disclosure on sustainability items, while Shanghai Stock Exchange engages in mandatory reporting for environmental items when the operations conducted by the companies are affecting the environment. The figure bellows summaries the main voluntary and mandatory non-financial requirements (Fig. 1):

Fig.1. Voluntary and mandatory non-financial requirements

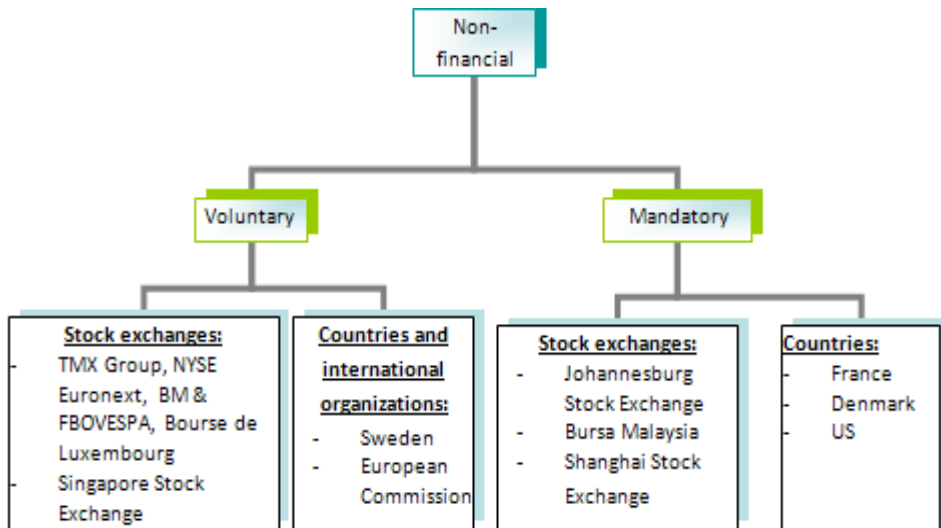

(Source: authors' projection)

In 2009, an estimated number of 1,400 organizations were disclosing non-financial reports, while in 2010 this number has met progress from a 29% increase. Therefore, we can expect that reporting would eventually shift to a mixture of financial and non-financial elements, being presented in an integrated form (Eccles & Saltzman, 2011). The UN Global Compact Leaders' Summit that in 2010 was discussing the effects of the crises for the global economy, stating very clear the need for a sustainable approach when rebalancing the economy (UN Global Compact-Accenture, 2010). Eccles & Saltzman (2011) perform an analysis upon non-financial reporting tendencies within the business world. The scholars mention large discrepancies between Europe and other continents, as the European Commission highly promotes non-financial information disclosure. Contrary to European countries, Japan, China and US maintain low disclosure levels of non-financial reporting.

A KPMG international survey published in 2008 shows that 77% of surveyed reporting companies use the GRI Guidelines. The survey analyses trends in CR reporting of the world's largest corporations, including the top 250 companies of the Fortune 500 (the global top 250 (G-250)), as well as the top 100 companies in 16

countries. It noted that over 80% of the G250 produce sustainability reports. On average, 45% of the top 100 companies in each of the surveyed countries produce sustainability reports - Japan and the United Kingdom lead the table at 93% and 91% respectively. South Africa is some way behind at 45%, but it is one of the leaders in integrating the sustainability report into the annual report (KPMG, 2008).

During the last 20 years, corporate non-financial reporting has developed from predominately single-issue reports (mostly focusing on the environment) to multi-issue reports or sustainability reports. Currently, this trend towards multi-issue reporting goes further towards 'integrated reporting', which means sustainability reporting integrated within the financial or annual report. Especially in the debate on the future of sustainability reporting this is one of the major topics.

Previous studies in the field of corporate disclosure reveal that that mandatory requirements for integrated reporting lead to increase of ESG disclosure (Solomon and Maroun, 2012) and all mandatory non-financial requirements generate corporate responsible organizations and a sustainable business environment (Ioannou and Serafeim, 2012). Solomon and Maroun (2012) analyzed the pre and post periods of mandating integrated reporting in South Africa. The academics studied 10 reports issued by South African companies and found that there is a positive evolution non financial disclosure and setting the connection to financial elements, and also that sustainability is being considered from the perspectives of "materiality and risk" (p. 31). UK, Germany and Spain are the most representative states that pursue on integrated reports initiatives, according to a report released by the Harvard Business School (Eccles et al., 2012). The study involved a sample of 2,255 firms from 23 countries. The authors analyzed the stage of integrated reporting by employing measurements of index ranking and key performance indicators.

A recent ACCA report (ACCA, 2011) presents an Australian case study of integrated reporting regarding financial and non-financial reporting trends for ASX 50 listed companies. Empirical evidence for an integration of non-financial information is searched among annual, and sustainability reports, as well as websites- mainly all the available online information-. The ACCA study employs six main criteria that enable integration, namely (ACCA, 2011: 13): mission and strategy, management approach, performance tracking, risk management, stakeholder engagement, format public reporting. The results do not indicate a relevant integration level for the information presented in IR. On the contrary, the annual reports seemed more sustainability/CSR reports than IR.

#### **4. Findings**

After computing the disclosure index for each company/report we performed an analysis on the regional concentration of the integrated reporting formation. Table no. 1 presents a comparison of the civil law countries according to the values of the disclosure index. By dividing the sum of DI to the number of companies corresponding to each state, we obtained an average for DI allows a classification of civil law countries from the perspective of integrated reporting information. However, we have to mention a limitation of our study, by identifying just one company presenting integrated reports in each of the civil law countries (except for Brazil). The average value for the disclosure index is meant to eliminate any inconsistency of the study that could be generated by the no. of companies per country distribution.

Table 1. Summary Analysis for Civil Law Countries

No. of companies	Headquarter	Sum of DI	Average DI Civil law
5	Brazil	1,9091	0,3818
1	Chile	0,1818	0,1818
1	Denmark	0,3636	0,3636
1	Japan	0,3636	0,3636
1	Mexic	0,1818	0,1818
4	Netherlands	1,3636	0,3409
1	South Korea	0,4545	0,4545
1	Spain	0,2727	0,2727
1	Switzerland	0,4545	0,4545

(Source: authors' compilation)

The figure below (Chart no. 1) illustrates the values from our table. Switzerland and South Korea register the highest concentration of IR disclosure (0,4545), followed by Brazil (0,3818), Denmark and Japan (0,3636). In Netherlands, the level of DI is 0,3409, while the IR from Spain shows a value of 0,2727. The last place is granted to Chile and Mexic (0,1818), that manifest the lowest level of integrated reporting information. We note that the highest IR level (Switzerland and South Korea) differs from the minimum one by 40%. Therefore, we can identify a gap between the most representative civil countries for IR initiative and the least interested ones. However, some of our results are contradictory to other findings from sustainability and IR literature (in its early stage). South Korea that finds itself on the top position in our DI research has been previously classified by Eccles et al. (2012) as an unsustainable country and IR reporting originates from sustainability, as SR precede IR. Despite being a promoter of mandatory non-financial reporting, through the issuance of the Danish Financial Statements Act, Denmark does not register the higher performance in IR, being situated after Switzerland, South Korea, and Brazil. In other cases, the level of IR demonstrates what scholars and academics mention regarding Japan, Brazil, or Spain. From social and environmental point of view, Japan is considered a country with sustainable investors (Eccles et al., 2012), but is not qualified as a sustainable country neither as having sustainable companies, which means that is situated somewhere in the middle on both sustainability line, and IR (as in our study), and in 2008 released a large proportion of the words' sustainability reports (KPMG, 2008), although maintaining a low level of non-financial information (Eccles & Saltzman, 2011). Brazil is considered a sustainable country (Eccles et al., 2012) and this statement is proved by the high DI level being position on the second position on our scale of civil law countries. Spain is also known as a predecessor of IR (Eccles et al., 2012).

Chart 1. Disclosure index variations per country - Civil Law

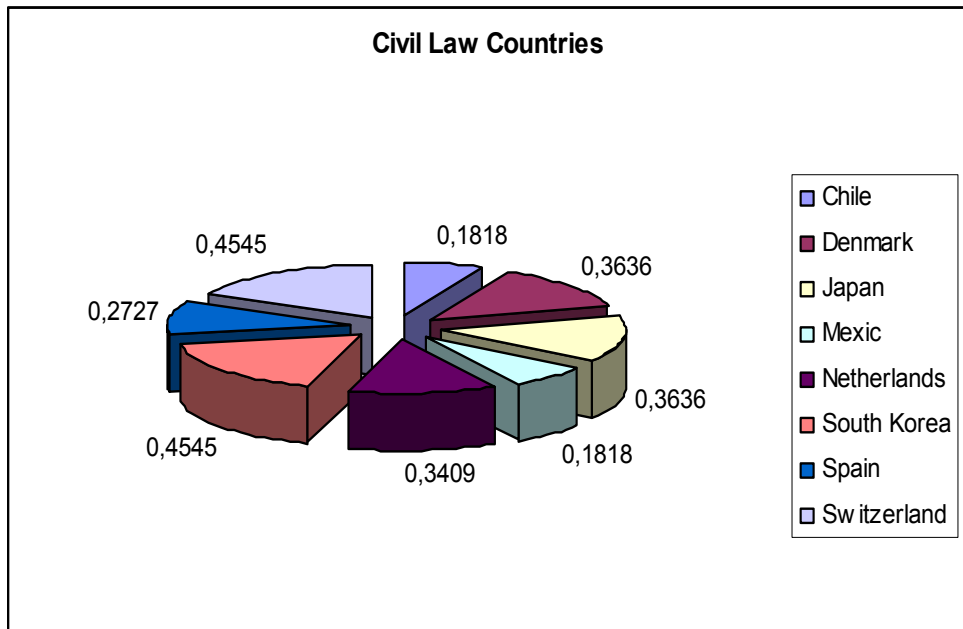

(Source: authors' compilation)

Table no. 2 shows the DI analysis for common law countries. The values for IR disclosure are incontestably higher than in case of civil law countries. Thus, we can deduce that common law countries are more IR oriented than the civil law ones. In case of common law countries, we had again an inconsistency in the number of companies per country. By computing the average disclosure index, we eliminate this effect.

Table 2. Summary Analysis - Common Law

No. of companies	Headquarter	Sum of DI	Average DI Common law
14	South Africa	4,6364	0,3312
4	Australia	1,5455	0,3864
3	Canada	1,2727	0,4242
1	China	0,4545	0,4545
1	Ireland	0,2727	0,2727
2	Sri Lanka	1,1818	0,5909

No. of companies	Headquarter	Sum of DI	Average DI Common law
18	UK	7,1818	0,3990
4	USA	1,9091	0,4773

*(Source: authors' compilation)*

The DI average (expressed as the division between sum of DI values and number of companies allocated to each country) sets Sri Lanka on the first place with a medium disclosure index of 0,5909, followed closely by USA (0,4773). This result is not a surprise as in 2002 the US was submitting the Sarbanes–Oxley Act for mandatory non-financial reporting. Classified as a state with sustainable investors (Eccles et al., 2012), according to Eccles and Salzman (2011) registers low scores for non-financial disclosure, which means improvements can still be made to attain the leaders performance (South Africa and Sri Lanka). Surprisingly enough, China is not on the last place, even if the literature mentions its lack of sustainability (Eccles and Salzman, 2011) and the fact that this country falls into the category of the unsustainable ones (Eccles et al., 2012). The next in line after China is Canada, with a DI of 0,4242. In addition, the Canadian group Vancity has been awarded by the IIRC with the title of Best Integrated Report. With an IR disclosure of 0,3990, UK is one of the top sustainable countries whose companies tend to report on non-financial information (Eccles et al., 2012, KPMG, 2008). Australia shows an IR level of 0,3864 and its attitude towards IR is underlined by the collaboration with the IIRC for promoting the integrated reports. However, the study developed by ACCA (ACCA, 2011) proves lack of integration of sustainability within annual reports along with the financial information in case of Australian companies. In addition, their reports contain only sustainability/CSR information, and the financial elements are missing. South Africa registers low disclosure values in comparison with the other common law countries, besides being known for its sustainable companies (Eccles et. al, 2012), and leading IR initiatives (KPMG, 2008) of mandatory non- financial initiatives through its stock exchange JSE (Eccles et. al, 2012) and even certain integrated reporting requirements for listed companies (Rossou, 2011). In addition, in 2010, one year before the implementation of the IIRC, South Africa sets up its own IR committee at national level, SA IRC- South African Integrated Reporting Committee. The SA-IRC has already established a framework for integrated reports, as being mandatory for corporations, already one step ahead the IIRC. The positive trend for IR disclosure in South Africa mentioned by Solomon and Maroun (2012) is based on the influence of mandatory IR reporting at national level, that demonstrates the strength of the political factor of common law nature. Finally, Ireland is the last state on our scale of common law countries, with 0,2727 level of IR. Chart no. 2 presents the distribution of the DI for integrated reports on common law countries.

Chart 2. Disclosure index variations per country- Common Law

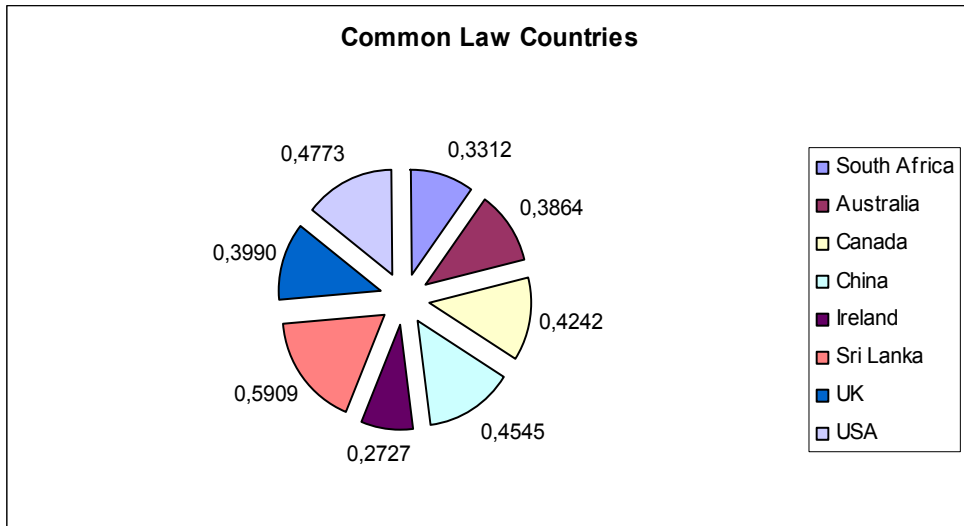

(Source: authors' compilation)

The last part of our analysis involves the comparison between civil and common law states in relation to integrated reporting (Chart 3). The findings suggest that IR disclosure level is higher in common law countries than in civil law countries. This statement is strengthened by previous empirical and theoretical studies that prove the role of most common law states in pursuing integrated reporting initiatives. Therefore, based on institutional theory and the political implications upon IR, we claim that companies from common law states disclose more information in accordance with IR principles and guidelines than the civil law states.

Chart 3. Civil Law versus Common Law Disclosure Index

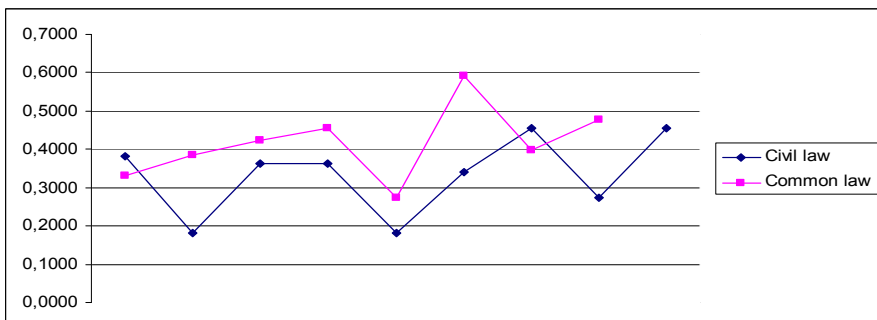

(Source: authors' compilation)

Finally, we can state that the legal system is a determinant factor for integrated reporting. However, our findings are not consistent with previous studies from literature (Jensen & Berg, 2011; Kolk and Perego, 2010; Kolk et al., 2001; Ball et al., 2000; La Porta et al., 1998), as organizations from civil law countries disclose are less representative for integrated reporting than those from civil law states.

## 5. Conclusions

The current paper is meant to provide new insights upon integrated reporting and institutional theory. We claim that the political factor influences the disclosure level of IR. We fundament our research on the institutional theory. The political influence on integrated reporting is tested using the origin of law – civil and common criteria. This classification was also used by other scholars and academics for conducting research on integrated reporting. Therefore, we undertake archival research, content analysis, and empirical investigation in to understand the political effect upon IR level. We analyze a sample of 58 companies from the IIRC database for a total of 68 annual integrated reports and we cover the period 2010- 2012. We discuss 17 states – 9 from civil law origin and 8 corresponding to common law. We presented previous findings from literature regarding some of the most prominent countries and mentioned possible implications of our results. On the whole, we consider that the political factor is an important determinant of integrated reporting along with the state in which the organization has its headquarter, by its legislative initiatives and other mandatory/voluntary requirements regarding corporate disclosure.

One of the limitations of the study is the finite number of integrated reports from our sample- from a larger population as more and more companies start to adopt integrated reporting practices. However, the diffusion of integrated reporting practices is time consuming, as organizations adopt integrated reporting on step-by step basis, from sustainability/ corporate social responsibility/ environmental reports to common financial and non-financial reports (that still can scarcely reflect items from the principles and elements mentioned by IIRC).

Further research could involve testing the IIRC principles and content elements on a larger sample and developing an econometric model with more variables such as company size, industry, profitability rates.

## References

- ACCA, (2011), *Adoption of integrated reporting by the ASX 50- A joint report from ACCA and the Net Balance Foundation*, [www.accaglobal.com](http://www.accaglobal.com)
- Bushman R.M., Piotroski J.D. (2006), Financial reporting incentives for conservative accounting. The influence of legal and political institution, *Journal of Accounting and Economics*, 42, pp. 107–148.
- Chen C.J.P., Jaggi B. (2000), Association between independent non-executive directors, family control and financial disclosures in Hong Kong, *Journal of Accounting and Public Policy*, 19, pp. 285-310.



- Eccles R., Ioannou I., Serafeim G. (2012), The Impact of a Corporate Culture of Sustainability on Corporate Behaviour and Performance, Working Paper, *Harvard Business School*, available online at <http://www.hbs.edu/research/pdf/12-035.pdf>
- Eccles R.G., Saltzman D. (2011), Achieving Sustainability through Integrated Reporting, *Stanford Social Innovation Review*, 9(3).
- Ferner A. (1997), Country of origin effects and HRM in multinational companies, *Human Resource Management Journal* 7, pp. 19–37.
- Gray R. (2006), Social, environmental and sustainability reporting and organizational value creation?: Whose value? Whose creation?, *Accounting, Auditing & Accountability Journal*, 19(6), pp. 793 – 819.
- Ioannou I., Serafeim G. (2012), The Consequences of Mandatory Corporate Sustainability Reporting, Working Paper, *Harvard Business School*, available online at <http://www.hbs.edu/research/pdf/11-100.pdf>.
- Jensen J.C., Berg N. (2012), Determinants of Traditional Sustainability Reporting Versus Integrated Reporting. An Institutionalism approach, *Business Strategy and the Environment*, 21(5), pp. 299- 306.
- Jensen M.C. (2001), Value Maximization, Stakeholder Theory and the Corporate Objective Function, in *Unfolding Thinking*, *European Financial Management Review* 7.
- Kolk A., Perego P. (2010), Determinants of the adoption of sustainability assurance statements: an international investigation, *Business Strategy and the Environment* 19, pp. 182–198.
- Kolk A., Walhain S., Van de Wateringen S. (2001), Environmental reporting by the Fortune Global 250: exploring the influence of nationality and sector, *Business Strategy and the Environment* 10, pp. 15–28.
- KPMG, (2008), International Survey of Corporate Responsibility Reporting 2008, KPMG International.
- La Porta R.F., Lopez-de-Silanes F., Shleifer A., Vishny R.W. (1998b), Law and finance, *Journal of Political Economy*, 106, pp. 1113–1155.
- Prencipe A. (2004), Proprietary costs and determinants of voluntary segment disclosure: Evidence from Italian listed companies, *European Accounting Review*, 13(2), pp. 319–340.
- Rossou R. (2011), *Integrating Sustainability Reporting*, Presentation delivered at the Women in Finance Conference, South Africa, <http://www.slideshare.net/Reana1/integrated-sustainability-reporting>.
- Rugman A.M. (2000), *The End of Globalization*. Random, London.
- Solomon J., Maroun W. (2012), *Integrated reporting: the influence of King III on social, ethical and environmental reporting*, The Association of Chartered Certified Accountants, London, available online at <http://www.accaglobal.com/content/dam/acca/global/PDF-technical/integrated-reporting/tech-tp-iirsa.pdf>
- Stanga K.G. (1976), Disclosure in published annual reports, *Financial Management*, (Winter), pp. 42-52.
- <https://www.vancity.com/MyCommunity/OurVision/RedefiningWealth/>  
<http://www.theiirc.org/resources-2/other-publications/emerging-integrated-reporting-database/>  
<http://www.theiirc.org/about/pilot-programme/>

## Appendix: Sample of Integrated Reports

Company	Organization type	Industry	Region	Headquarter
ABSA	Private Company	Financial services	Africa	South Africa
ACCA	Other	Professional services	Europe	UK
AEGON	Public Company	Financial services	Europe	Netherlands
Aggreko	Public Company	Industrials	Europe	UK
AkzoNobel	Public Company	Industrials	Europe	Netherlands
American Electric Power	Public Company	Utilities	North America	USA
Anglo American	Public Company	Basic materials	Europe	Luxembourg
Anglo Platinum	Public Company	Basic materials	Africa	South Africa
ARM	Public Company	Industrials	Europe	UK
AstraZeneca	Public Company	Healthcare	Europe	UK
BAE Systems	Public Company	Industrials	Europe	UK
BHP Biliton	Public Company	Basic materials	Oceania	Australia
BNDES	Public Company	Financial services	South America	Brazil
Canadian Real Estate Investment Trust (CREIT)	Public Company	Financial services	North America	Canada
CLP	Public Company	Utilities	Asia	China
Coca-Cola	Public Company	Consumer goods	North America	USA
Danone	Public Company	Consumer goods	Europe	Netherlands
Diageo	Public Company	Consumer goods	Europe	Ireland
DIMO	Public Company	Industrials	Asia	Sri Lanka
Eskom	Public Company	Utilities	Africa	South Africa
Exxaro	Public Company	Basic materials	Africa	South Africa
Fibra	Public Company	Basic materials	South America	Brazil
Fresnillo	Public Company	Basic materials	North America	Mexic
Go-Ahead	Public Company	Consumer services	Europe	UK

<b>Company</b>	<b>Organization type</b>	<b>Industry</b>	<b>Region</b>	<b>Headquarter</b>
Gold Fields	Public Company	Basic materials	Africa	South Africa
HBSC	Public Company	Financial services	Europe	UK
Hyundai Engineering & Constructions	Public Company	Industrials	Asia	South Korea
Implats	Public Company	Basic materials	Africa	South Africa
Indra	Public Company	Technology	Europe	Spain
Liberty Holdings	Private Company	Financial services	Africa	South Africa
Marks & Spencer	Public Company	Consumer goods	Europe	UK
Masisa	Public Company	Consumer goods	South America	Chile
National Australia Bank	Public Company	Financial services	Australasia	Australia
Natura	Public Company	Consumer goods	South America	Brazil
Nedbank	Public Company	Financial services	Africa	South Africa
Novo Nordisk	Public Company	Healthcare	Europe	Denmark
Petrobras	Public Company	Oil and gas	South America	Brazil
PotashCorp	Public Company	Basic materials	North America	Canada
Pretoria Portland Cement Company	Public Company	Industrials	Africa	South Africa
Rio Tinto	Public Company	Basic materials	Europe	UK
Royal DSM	Public Company	Healthcare	Europe	Netherlands
Sasol	Public Company	Oil and gas	Africa	South Africa
Smithfield	Public Company	Consumer goods	North America	USA
Standard Bank	Public Company	Financial services	Europe	UK
Stockland	Public Company	Financial services	Australasia	Australia
Syngenta	Public Company	Healthcare	Europe	Switzerland
Takeda	Public Company	Healthcare	Asia	Japan
The Crown Estate	Other	Financial services	Europe	UK
Truworths	Public Company	Consumer goods	Africa	South Africa
Tullow Oil	Public Company	Oil and gas	Europe	UK

<b>Company</b>	<b>Organization type</b>	<b>Industry</b>	<b>Region</b>	<b>Headquarter</b>
Unilever	Public Company	Consumer goods	Europe North	UK
Vancity	Public Company	Financial services	America	Canada
Vodacom	Public Company	Telecommunications	Africa	South Africa
Vodafone	Public Company	Telecommunications	Europe South	UK
Votorantium	Public Company	Industrials	America	Brazil
Wilderness	Public Company	Consumer services	Africa	South Africa
Woodside Petroleum Ltd	Public Company	Oil and gas	Australasia	Australia
Xstrata	Public Company	Basic materials	Europe	UK

## THE INFLUENCE OF SELECTED MOBILE-DEVICE RECREATION FACTORS ON QUALITY OF LIFE: A GENDER-BASED PERSPECTIVE

**Nobukhosi DLODLO\***

Vaal University of Technology, South Africa

**Abstract.** Notwithstanding the trajectory in mobile-device based recreation participation, limited attention has been devoted to studies on the factors influencing m-recreation as well as the subsequent relationships with quality of life among users. A quantitative study was followed using a structured questionnaire that incorporated existing scales. The survey rendered 269 usable responses. Initially, an exploratory factor analysis (EFA) was conducted with principal components, whereby a four-factor structure was established, revealing the underlying dimensions of participation in mobile-device recreation. The identified factors pertained to hedonistic consumption behaviour (enjoyment); involuntary consumption behaviour (dependency); obsessive consumption behaviour (addiction); as well as mandatory consumption behaviour (critical mass). The results of this study provide a platform for further investigations into the properties of an m-recreation scale, with a view to conduct further validity assessments that may serve to delineate the specific criteria that are relevant for similar studies. Therefore, cumulative research is required to keep abreast of behavioural trends and changes in the recreational motivations of users, along mobile device platforms.

**JEL classification:** M220

**Keywords:** mobile-device, recreation, m-recreation, quality of life, gender, users

### 1. Introduction

New information and communication technologies (ICT) such as computers, Internet and mobile devices, have tremendously altered individuals' everyday lifestyles (Shambare *et al.*, 2012). Similarly, global enthusiasm for mobile, digital recreational applications has been phenomenal (Schiano, Elliot and Bellotti, 2007). This trajectory has been spiralled by the widespread diffusion of mobile devices such as tablets, Ipads, netbooks, as well as the maturing nature of the mobile telephone market both in South Africa and beyond (Dimmick *et al.*, 2011). Being among the African countries with the highest mobile-device density (Potgieter, 2014), South Africa is a model example of the successful development of mobile devices as a technological icon that has morphed into an ultimate

---

\* Corresponding author. Address: X021 Vanderbijlpark, South Africa, Tel: +27169507562, E-mail: nobukhosid@vut.ac.za

recreational vehicle, empowering leisure business entities to establish a universal electronic presence.

In this study, a mobile device shall encompass all tools that allow access to an Internet network (Kaplan, 2011). This includes, *inter alia*; cellular phones, smartphones, tablet PCs, personal digital assistant and a net book, if it can access different types of wireless networks such as WLAN, 3G and WiMAX (Abdelkarim and Nasereddin, 2010). Moreover, a mobile device should be identified uniquely, as through a built-in SIM card from an existing mobile phone operator. This implies therefore, that mobile devices are highly personalised tools that cannot be commonly shared among users (Elphick, 2007). Mobile devices usually act as an on-the-go talking device (Cawley and Hynes, 2010), an Internet portal, a multichannel shopping device (Gao *et al.*, 2010), a social networking platform (Bicen and Cavus, 2010), a personal organiser or diary (Bruner and Kumar, 2005), a new type of ticket and money (Ondrus and Pigneur, 2006) and an entertainment platform (Salo and Karjaluoto, 2007). In the information age, mobile devices have become an important social accessory. Aoki and Downes (2003) further argued that mobile devices (more precisely the mobile phone) are no longer linked to a space but rather epitomise a tool that is linked exclusively to an individual's way of life (Boyd and Ellison, 2008).

### **1.1. The millennial generation and mobile-device usage**

A report compiled by All Media and Product Survey (2008) revealed that more than 60 percent of all South Africans between the ages of 16 and 30 own an Internet-enabled mobile device. This rapid growth, up from just 18 percent in 2000 (International Telecommunications Union, 2011) is at least partially due to the immense popularity of prepaid subscriptions and low-cost mobile phones (Hodge, 2005), which have made it possible for many of the youth in the country to own or use a mobile device. This age cohort is independent, optimistic and generally exhibits high social self-esteem (Dlodlo and Mahlangu, 2013). In addition, they possess tremendous spending power (Noble *et al.*, 2009). They are also perceptive, pragmatic, value oriented and brand embracing (Schiffman and Kanuk, 2010). This suggests that these users usually attempt novel, unprecedented, innovative and risk-taking behaviour on their mobile devices (Cant and Machado, 2005).

As Qiu (2003) observed, going online through a plethora of mobile devices has been widely advertised as fashionable and cool entertainment. In China, mobile devices are utilised for entertainment rather than for more instrumental purposes such as information seeking (Liu, 2010). In the western countries such as the United Kingdom and Norway, young people regularly use their mobile devices to access the Internet for information-seeking related to their school work, as well as for recreational and social purposes (Livingstone, 2008), while Finnish youths are habitually pre-occupied with social chatting and communication on their mobile devices (Oksman and Turtiainen, 2004). Similarly, the South African consumer market which is highly swag-driven, techno-savvy and constantly in the pursuit of 'eternal youthfulness' presents a highly attractive segment that is a portrait of the post-modernistic consumer in the context of a developing country. This Internet (net) generation depicts specific characteristics and lifestyle patterns that have compelled this cohort to become the major target of online recreation through mobile devices. Kaplan (2011) opined that it would be wise for business

practitioners, intent on focusing locally to turn to mobile devices, as this platform has been tipped into the mainstream culture of many young people. Schiffman and Kanuk (2010) further underscored that teenagers and individuals aged between 20 and 30 neither read newspapers nor watch television regularly, but rather choose to spend more of their time conducting recreational activities on their mobile devices.

## **1.2. Framing the concept of mobile-device recreation (m-recreation)**

Four basic orientations will be used to define recreation, namely (1) time, (2) active involvement, (3) effects of leisure and (4) a holistic approach. Edgington (1992:4) used time as the underpinning factor by defining recreation as “the use of time for amusement, entertainment, participation and creativity.” This may incorporate an individual’s complete withdrawal from involvement, an antithesis to work that utilises the element of time in a creative manner (Murphy, 1974). The second orientation focuses on recreation as a form of activity. Neumeyer and Neumeyer (1958:261) suggested that recreation may involve “any activity that is pursued during one’s free time, either individually or collectively; that gives pleasure and presents the merits of its own immediate appeal....” However, this activity may oftentimes lead to passive, emotional and creative involvement by the participants. Elements such as inherent satisfaction and voluntary participation in a socially accepted and constructive manner have also been included in other operationalisations of this term (Nolan and Surujlal, 2009; Torkildsen, 2005). Interestingly, the Sports Council Report (1969) pointed out that recreation is not essentially synonymous with physical activity and sport, as it only describes the “purposeful use of one’s leisure time”. As such, it may incorporate activities such as sports, games, arts, music, dramatics, travel, hobbies and other outdoor social activities (Salo and Karjaluo, 2007)..

Thirdly, recreation may be examined in terms of its effects on the participant, in contrast to sheer idleness or complete rest (indolence). This is because recreation and leisure are often viewed as the periods spent out of work or essential domestic activity for the purpose of relaxation, entertainment or rest. Essentially, the term recreation stems from the Latin word *recreatio*, which means to refresh (Torkildsen, 2005). While some individuals may be motivated by a desire to be seen, and consequently, participate in recreational activities in order to fulfil this intrinsic need for dignity and acquired status. Other scholars opine that recreation, as a way of life, is set to provide improved quality of life through increased work productivity, enhanced relationships, relaxation, health and fitness and analogous therapeutic effects of leisure involvement (Kaplan, 2011). On the other hand, Hooper and Zhou (2007) asserted that while recreation conducted through mobile devices may stimulate the mind, it also largely serves as a sedentary activity that has no fitness benefits and offers limited health advantages. The fourth orientation is a cocktail of all the aforementioned dimensions that seeks to combine the holistic attributes of time, active engagement and overt effects on the users. This presents the departure point for the concept of mobile-device recreation (termed m-recreation), the focus of this paper. As a result of the growing influence of the net generation, the impact of mobile technology on young people has been increasingly manifested in their consumption styles and mobile-device based activities. One area where these consumption lifestyles have been solidly

co-produced by the users is online leisure and recreation. It is in the light of this view, coupled with the absence of a universally accepted definition of mobile-device recreation, that the author coined an operational definition.

Mobile-device recreation is the term that encapsulates the process of spending time in active, social engagement with others on a plethora of Internet-enabled mobile devices, regardless of the consequences of such engagement on personal health. This may include the use of mobile applications such as digital photography, games, Internet dating, listening to music, watching videos, social chats and networking (McClaren, 2007). Nonetheless, while it may be argued that near-universal access of the mobile device has been achieved globally, the degree to which this status quo has morphed the mobile device into an ultimate recreational vehicle is yet to be explored. Therefore, apart from determining the advantages and disadvantages of wireless mobile technologies, asking the question of whether mobile-device recreation will contribute to improved life quality is a better criterion for establishing the importance of mobile-device recreation in the lives of young people.

### **1.3. Quality of life**

Burke (1996:356) defined quality of life as “being able to find pleasure and meaning in doing what one wanted to do, where and when one wanted to do it.” One way that has been instrumental in facilitating the physical, emotional and mental well-being of young people over the years has been through participation in recreation. The many documented health benefits of staying active include reduced obesity, a diminished risk of disease, an enhanced immune system and most importantly, increased life expectancy (Torkildsen, 2005). Physical activity alleviates the chances of individuals becoming exposed to contra-mental conditions such as depression, anxiety and reduced self-esteem. Studies undertaken by Mence (2003) revealed that respondents who reported higher levels of participation in leisure activities also reported higher measures of satisfaction with life. The digital media and the cyber-worlds of new technology have responded perfectly to the need for play and entertainment amongst the youth, with an increased likelihood for enhanced quality of life (Kaplan, 2006), especially since wireless communication systems are becoming cheaper, easier to implement and time-saving. However, frequent inactivity and sedentary behavioural traits (often associated with m-recreation) are subject to a host of unhealthy habits such as over-eating, smoking and drinking. As such, these media spectacles have been criticised for their alleged adverse effects on young people, such as isolation and false consciousness, caused by the virtual world. In most instances, the time spent on mobile-device leisure activities naturally sanctions an impasse on the productivity of the youth, either in the schooling environment, or their respective work stations (Hooper and Zhou, 2007). Hence, mobile device oriented recreation slackens in enhancing relationships and improving health and fitness among users.

### **1.4. Gender-based participation in mobile-device recreation**

Historically, there appears to have been gender differences in relation to the uptake of new technology. Past research has established that men are more likely than women to hold positive attitudes towards computers and are thus more likely to embrace computer technology faster (Ray, Sormunen and Harris, 1999).



Following on from this notion, logic would lead to the conclusion that males will be more likely than females to fall prey to the use of Internet-enabled mobile devices for recreation, as they are more likely to use computers more frequently, in the first instance. Some research has shown that this is indeed the case (Young, 2004; Griffiths, 1998; Morahan-Martin and Schumacher, 2000). In support, a plethora of studies have suggested that males (rather than females) tend to be more dependent on mobile devices for leisurely activities such as watching pornography (Baron, 2004; Ray *et al.*, 1999) as well as gambling (Partarelli and Browne, 2002; Lin and Tsai, 2002; Morahan-Martin and Schumacher, 2000).

Drawing on from the literature, it becomes difficult therefore to establish how m-recreation will translate into quality of life improvement among both males and females within the context of South African youths. This is true within the South African context which is currently suffering from the post-trauma of the apartheid legacy and reeling from the problem of “separateness”. Relatedly, the persistent gender imbalances existing in the South African consumer segment leading to significant variations in mobile device consumption decisions have been eminent. Thus, cumulative research on the influence of various m-recreation factors on the quality of life among both male and female users merited the authors’ attention. Based on the aforementioned discussion, the following null hypothesis is set for the study:

- H: There are no differences between male and female perceptions of the influence of m-recreation factors on quality of life.

Following on from Maslow’s motivation model, Hooper and Zhou (2007) posited that human behaviour can be viewed as the actual performance of intended activities, driven by certain underlying motives. The current research submits that recreational engagement and participation in online mobile devices is motivated by selected behavioural attributes; namely hedonistic-related consumption behaviour (enjoyment), involuntary consumption behaviour (dependency), obsessive consumption behaviour (addiction), as well as mandatory consumption behaviour (critical mass).

#### Hedonistic motives for m-recreation participation

Bruner and Kumar (2005) highlighted that perceptions of enjoyment, exhilaration and other forms of positive internal gratification derived from mobile devices are usually a key determinant of m-recreation usage. As such, technology enjoyment is reasoned behaviour, driven by the pleasure and excitement of pursuing leisure activities on unique platforms such as mobile phones (Venkatesh, 2000). This may be measured in terms of the level of internal gratification, pleasure and enjoyment, which logically delivers an impetus for consumers to reflect positive attitudes toward mobile devices as recreational tools (Venkatesh, 2000). Some previous studies have identified males as deriving greater utility from mobile Internet use (Partarelli and Browne, 2002). On the contrary, Bosshart and Hellmuller (2009) cited that female participation in mobile device recreational games has been largely determined by the pleasure and fulfilling thrill of engaging in the activity (Salo and Karjaluto, 2007). This implies that the emotional satisfaction that is derived from being socially connected with others while using

mobile devices is the most important motivational factor behind m-recreation among certain gender cohorts. Therefore, drawing from the aforementioned empirical evidence, the following hypothesis is formulated for the study:

H: There are differences between male and female perceptions of m-recreation technology enjoyment motives on quality of life.

#### Involuntary motives for m-recreation participation

Wilska's findings (2003) indicated that mobile phone usage has become trendy and impulsive. In other words, as adopters begin using mobile phones regularly, these tools become part of the users' lives to such an extent that the users feel the urge to utilise the devices any free minute which they get, often without planning (Hooper and Zhou, 2007). Past research has confirmed dependency as being an indicator of problematic usage of mobile devices as individuals demonstrate extensive reliance on their mobile devices, despite the negative consequences of such behaviour (Igarashi *et al.*, 2008). Bianchi and Phillips (2005) found that cell phone dependents usually preoccupy themselves with recreation on mobile devices and become worried with the thought of missing out on a social chat when out of range from the mobile device. Such behaviour is different from addiction because usually it is motivated by the attached importance of the social norm *inter alia*; the attached importance of leisure and recreation to the users. Hooper and Zhou (2007) supported Billieux *et al.*'s (2008) notion that the use of mobile devices may result in problematic usage, when they highlighted that the mobile device may be used relentlessly for the purpose of recreation, subsequently leading to the development of highly impulsive and dependent behaviour. Notwithstanding this, the influence of the dependency attribute on the users' quality of life, as well as the significance of the gender-based differences between two user groups (males and females) is yet to be defined empirically. Therefore, the following hypothesis is formulated for the study:

H: There are differences between male and female perceptions of the influence of m-recreation technology dependency motives on quality of life.

#### Obsession/Addiction motives for m-recreation participation

In spite of the broadly perceived merits of mobile devices, psychologists and educators have been aware of the negative impacts of this technology, especially the overuse or misuse and the related physical and psychological problems (Walsh, White and Young, 2010). One of the most common of these problems that has been identified in the rapidly burgeoning literature on Internet technology is the seriously dysfunctional patterns of inordinate technology use, often referred to as 'addiction' or 'pathological use'. Some scholars have demarcated addiction as any activity, substance, object or behaviour that has become the major focus of a person's life to the exclusion of other productive activities (Hanley and Wilhelm, 1992). The operationalisation of Leung (2007) shall be used to delineate m-recreation addiction as 'the maladaptive patterns of m-recreational activity leading to significant psychological impairment'.

This problem is rising in prevalence, affecting people with varying frequency around the world and also negatively impacting on the academic, relationship, financial and occupational aspects of many lives (Han and Hur, 2004). Usually, addictive tendencies lead to reduced productivity in one's life to an extent that they begin to harm the individual (or others associated with the user) physically, mentally, or socially (Shaw and Black, 2008; Young, 2004). As such, obsessive use of mobile devices for recreation is likely to have an influence on the overall quality of life among users (Hooper and Zhou, 2007). Furthermore, research indicates that men are more likely to spend their time with mobile games or other non-social activities, which could lead them to become more isolated (Young, 2007). On the other hand, women are more likely to spend more time in front of their mobile screens participating in social interaction, which could help them to recover from symptoms of depression or create connections and recreational opportunities that will translate into non-digital activities (Leung, 2007). However, specific research is required to determine whether the men and women in this particular study context correspond to these general trends of computer and mobile gaming activities. Notwithstanding this, the influence of addiction on the quality of life of m-recreation users' is noteworthy. Therefore, the current study proposes that:

- H: There are differences between male and female perceptions of the influence of m-recreation technology addiction motives on quality of life.

#### Mandatory motive for m-recreation participation

Internet-based mobile-device recreation requires collective efforts and interdependence between two or more people and this is fostered through conversation and sharing (Markus, 1987). Therefore, the benefits of using m-recreation can be derived in the existence of a networking community (Li *et al.* 2005). Further empirical evidence points to positive and statistically significant relationships between perceived critical mass (PCM) and behavioural intention to use Internet technology (Lou *et al.*, 2000). Markus' (1987:503) theory pointed to some individuals who have "the personal characteristics of being sought after" by other people. These individuals may be used as a reference point by other individuals, who may, consequently, exhibit positive attitudes towards m-recreation, thus creating a good atmosphere for using the mobile-device technology for recreation. Social science scholars refer to critical mass as "a small segment of the population that chooses to make big contributions to the collective action" (Oliver *et al.*, 1985). Based on the critical mass theory espoused by Markus (1987) and the social influence theory (Fulk, 1993), perceived critical mass is believed to have a direct effect on technology acceptance, adoption and usage. Several empirical studies have examined the direct effect and found it to be statistically significant in different samples (Soe and Markus, 1993; Hsu and Lu, 2004). This implies that a minimal number of adopters of an interactive technology should be present for the technology to yield positive impacts such as enhanced quality of life for the users. Perceived critical mass (PCM) is the individual's perception of the minimum number of users that are necessary to influence m-recreation participation and correspondingly, the users' overall quality of life. Other scholars have highlighted that the extent to which male and female users are influenced by the availability of

a critical mass in their m-recreation participation decision is still unclear (Lou, *et al.*, 2000). Moreover, the strength and direction of the relationship between critical mass and enhanced quality of life among male and female users, is still unknown. Therefore, the following hypothesis is formulated for the study:

H: There are differences between male and female perceptions of the influence of the m-recreation critical mass motive on quality of life.

### **1.5. Problem investigated**

Literature suggests that recreation and leisure is a discipline that has attracted widespread research, especially in the areas of recreation management, including its associated benefits among professionals (Alla *et al.* 2007), working women (Bialeschki, 1990; Nolan and Surujlal, 2009), elderly (Surujlal and Dhurup, 2009), intellectually disabled children (Dhurup and Surujlal, 2009) as well as the youth (Liu, 2010). The need for recreation has been widely intensified by urban congestion, unavailability of land, pollution of waterways and the increasing demand for novel methods of refreshing by consumers (Hutchinson, 1951). Consequently, the mobile phone, amongst other ubiquitous devices, has also become a convenient platform for the development of non-traditional recreational activities among the youthful generation (Wilska, 2003).

As the popularity of ICT-driven leisure channels increases, mobile-device usage has been tipped into mainstream recreation culture among users, leaving no part of the society with immunity from its effects. This is particularly true for young adults, who increasingly consider mobile devices and technologies as part of their being and identity (Hooper and Zhou, 2007; Madrid, 2003). However, despite this, very little research attention has focused on this phenomenon, and even less has tested these claims empirically. There has been little description (to date) of the ways that young people are adopting and using mobile technologies, and so there remains limited understanding of the level of participation in mobile-device recreation among both male and female users. Within the same vein, the rapid development of technology and its growing penetration into society combined with the uncertainty, puerility and vacillation of both male and female adolescents is a loaded situation. Therefore, to be able to contribute to leisure and recreation literature in South Africa, this research aimed to uncover the various factors that influence m-recreation participation among users within a developing country context (South Africa). Furthermore, the possible existence of differences in the uptake of m-recreation technology by individuals of different gender orientations, have scantily been explored in literature, although such sexual based categorisations could have implications on the future development of novel, mobile recreation software with gender-appropriate usability functions. It should also be noted that mobile phones are becoming more varied in their use and new recreation applications appear to be more attractive to selected demographic segments rather than others (Venkatesh, Spier and Morris, 2002). Therefore, this study seeks to provide a logical foundation for the categorisation of m-recreation motives and quality of life among male and female users with a view to inspire future studies on the subject.

## **2. Methodology**

The study made use of a quantitative research design using a self-administered and structured survey instrument to obtain information from respondents who participate in recreation using their mobile devices.

### **2.1. Setting and sample**

The survey was conducted at both shopping malls and two university campuses where it was considered simpler to identify an accurate representation of the qualifying age group. While these two groups may appear to represent two separate populations, past studies (Livingstone, 2008; Hooper and Zhou, 2007; Shambare et al., 2012) focusing on young consumers have tended to combine consumers under 30 years old as one population group. The choice for including the entire spectrum of mobile-device users stems from the aforementioned views. The youthful age group was targeted because they were the heaviest users of the mobile devices (Leung and Wei, 2000). Those aged between 18 and 30 years represent the student population currently in tertiary institutions (Wolburg and Pokrywczynski, 2001; Kumar and Lim, 2008) and are, therefore, regarded as representing the largest demographic group that are currently active on mobile platforms (Walsh *et al.*, 2010; Choi *et al.*, 2008). A non-probability purposive sampling method was used in the study to randomly select qualifying respondents. The universities and shopping malls in Southern Gauteng province were used to draw the sample, in the absence of a comprehensive sample frame. Representation was achieved by ensuring that only those individuals, both males and females between 18 and 30 years, who were actively engaged in the mobile-device recreation and such-related activities, were selected because it was believed that they could offer valuable contributions to the research questions. Consequentially, inclusion-exclusion criteria were employed in the study by incorporating only those users who had some minimum experience ( $\geq 12$  months) with Internet enabled m-recreation, rather than those without such experience. This was done in order to facilitate the external validity of this study.

### **2.2. Item generation and measuring instrument**

The survey questionnaire consisted of two parts. The first part recorded the respondents' demographic information with variables such as age, gender, educational levels attained, experience with m-recreation etc. The second part recorded the respondents' perception on each variable, using statements based on a review of existing multi-item scales or similar scales, initially developed by other scholars. The mobile phone problem use scale (MPPUS), developed by Bianchi and Phillips (2005), was adapted to measure the addictive tendencies amongst the users of m-recreation in this study. The eight items included under this scale were initially used for screening gambling problems, then the development of a composite mobile phone addiction index (MPAI) instrument and in the formulation of an Internet addiction instrument by Young (2007). Similarly, Hooper and Zhou's mobile phone usage scale (MPUS) (2007) was adapted and used to collect primary data on the extent to which youthful consumers are dependent on mobile devices for synchronising their daily activities. Perceived enjoyment was measured by items adapted from Venkatesh *et al.* (2002), who capture the hedonistic attribute inherent in the use of technology. Similarly, this study did not ignore the measures

of a critical mass, as elucidated by other proponents of the critical mass theory (Lou *et al.*, 2000; Hsu and Lu, 2004); whereas, measures of quality of life were taken from the scales of Kaplan (2006) and Mence (2003). The overall scale consisted of 38 items that were anchored on a Likert scale ranging from one (strongly disagree) to seven (strongly agree).

### **2.3. Data collection procedures**

Data were gathered from a non-probability sample of 400 respondents ranging from 18 to 30 years of age ( $M=19.4$ ) who responded to a self-administered survey between August 2012 and December 2012. The selected sample size was consistent with previous studies (Ling, 2000; Burns, 2005; Schiano *et al.*, 2007; Hooper and Zhou, 2007; Abdelkarim and Nasereddin, 2010) that examined the usage of mobile phones devices among youthful populations. In addition, determination of the sample size was based on the prescription of Avkiran (1994) who suggested that sample sizes ranging between 200 and 500 should be used if the study is utilising more than one hypothesis.

The author, with the assistance of a trained post-graduate student, was involved in the data collection process. The survey was conducted on different days and at different times of the week in order to achieve randomisation. Ethical clearance was obtained from the faculty research committee of the two institutions where the survey was conducted (ethical clearance number 2012/07/13-4). The respondents were informed of the purpose of the study, prior to administration, through a cover letter that accompanied the questionnaire. The cover letter and opening statements on the questionnaire cited the purpose, nature and legitimacy of the study (Welman and Kruger, 2001). The survey specified confidentiality, informed consent as well as a withdrawal (opt-out) option at any time for the respondents. In addition, the cover letter further specified that participation would be voluntary and no harm or victimisation would be inflicted upon the respondents. Consequently, of the 400 questionnaires distributed, 301 were returned, and from those only 269 questionnaires were considered usable, thus representing a 67 percent response rate.

## **3. Data analysis**

The data were captured and analysed using SPSS Version 21.0 for Windows.

### **3.1. Sample composition**

There were more female (52%;  $n=141$ ) than male (48%;  $n=128$ ) respondents in the sample. The majority of the respondents (45%;  $n=121$ ) were between the ages of 20 to 25 years, with a larger proportion of the sample consisting of respondents of an African descent (96%;  $n=258$ ) owing to the location of the survey site (Southern Gauteng, South Africa). In terms of ownership of Internet-enabled mobile devices, the majority of the respondents conceded to owning smart phones (80%;  $n=216$ ), followed by tablet owners (6%;  $n=16$ ), personal digital assistant owners (7%;  $n=18$ ), and laptop or notebook owners (7%;  $n=19$ ). Nonetheless, the majority of the respondents purported to seldom spending time engaging in physical exercise (35%;  $n=94$ ) whilst there remains a

widespread participation on mobile device recreation with respondents (64%; n=172) spending more than three hours daily recreating on their mobile devices.

### 3.2. Exploratory factor analysis (EFA)

Firstly, an exploratory factor analysis procedure was performed in this study using the Principal Component extraction method with Kaiser Normalization. The Kaiser-Meyer-Olkin measure of sampling adequacy (KMO=.719) was above the benchmark level of .70 as suggested by Malhotra (2010). An assessment of the Bartlett's test of sphericity revealed an approximate chi-square value of 827.888 with 120 degrees of freedom, significant at the  $p < 0.000$  level.

Both over-extraction and under-extraction of factors retained for rotation can have deleterious effects on the results. In relation to this, four m-recreation dimensions were identified by an iterative process of deleting items that did not load higher than 0.50 on the standardised factor loadings thus providing an assessment of construct validity (all factor loadings of at least 0.50). Factor loadings below .0.50 were suppressed (nine items were eliminated from the scale) and items were assigned to the factor that produced the highest item loading without cross-loading onto another factor. This is consistent with Hair *et al.* (2010) who suggest that factor loadings greater than  $\pm 0.30$  are considered to meet the minimum levels, loadings of  $\pm 0.40$  are considered important and loading of  $\pm 0.50$  and greater are considered more important. Notably, the default measure used in this study (as in most statistical software packages) was to use Kaiser's (1956) "eigenvalues greater than one", scree plot and total variance extracted from the factors (>60% criterion). Floyd and Widaman (1995) suggested that the scree test is a more accurate method for retaining factors than the Kaiser–Guttman criterion and therefore, an inspection of the scree plot revealed a clear break after the 5<sup>th</sup> component, leading to the final decision to retain five components. These factors were rotated to position of maximum orthogonality through Varimax rotation in seven iterations and altogether explained 56.3% of the total variance, which is considered good for exploratory factor extraction (Malhotra, 2010) while the other 43.6% is accounted for by extraneous variables that do not constitute part of this study. These factors were labelled technology enjoyment, addiction, dependency, critical mass and quality of life. The description of the factors, percentage of variance, description and eigenvalues are presented in Table 1 of this study.

Factor one, labelled *enjoyment* comprised six variables and accounted for 32.2% of the variance in the study with an eigen value of 7.459. In addition, high factor loadings were obtained on this sub-scale ( $.505 \leq TE \text{ factor loadings} \leq .734$ ) as well as high communalities ( $.434 \leq TE \text{ communalities} \leq .511$ ), thus confirming the internal validity of the factor. Enjoyment is perceived as the affective outcome of m-recreation participation. M-recreation provides a new channel whereby young people may acquire physical and mental restoration from conventional work practises, in a self-paced and interactive manner; feeling more playful, excited and amused in the process (Aoki and Downes, 2003). Therefore, it is expected that if users perceive m-recreation participation to be enjoyable, favourable feelings will develop culminating into happiness and a tranquil mind state.

Table 1: M-recreation participation dimensions, quality of life and description of dimensions

Factor	Label	Items	Percentage of variance explained	Eigen Value	Description
1	Technology enjoyment (TE)	6	32.162	7.459	Enjoyment relates to the affective elements derived from accepting m-recreation tools such as pleasure, fun, appeal, excitement, entertainment and other positive experiences
2	Technology dependency (TD)	5	11.547	3.961	relentless pre-occupation with the mobile device to extends that users find themselves engaging in m-recreation while eating, walking or talking to others
3	Technology addiction (TA)	7	5.697	3.324	The habitual compulsion to engage in m-recreation activities extensively, notwithstanding the devastating consequences on the individual's physical, social, spiritual, mental and financial well-being
4	Critical Mass (CM)	7	3.769	1.638	The power of group social influence in predicting users' decisions to participate in m-recreation activities
5	QOL	4	3.211	1.037	the general well-being and happiness of individuals in the era of mobile device related recreational pursuits

Factor two, labelled *dependency* comprised five variables and accounted for 11.5% of the variance in the study with an eigen value of 3.961. In addition, high factor loadings were obtained on this sub-scale ( $.581 \leq TD$  factor loadings  $\leq .656$ ) as well as high communalities ( $.441 \leq TD$  communalities  $\leq .556$ ), thus confirming the internal validity of the factor. The five items that make up this factor were reverse coded in order to capture the full essence of involuntary pre-occupation with m-recreation that has become uncontrollable. Items on this scale included "feeling an urgent impulse to participate in m-recreation," participating every free minute that I am awake," "being pre-occupied with m-recreation daily," "feeling an irresistible urge to participate" and "participating in m-recreation without planning." In their study, Billieux *et al.* (2008) refer to this urgency in usage as a key driver that compels a majority of users to rely on their mobile devices for recreation.

Factor three, labelled *addiction* comprised seven variables and accounted for 5.7% of the variance in the study with an eigen value of 3.324. In addition, high factor loadings were obtained on this sub-scale ( $.645 \leq TA$  factor loadings  $\leq .757$ ), as well as high communalities ( $.517 \leq TA$  communalities  $\leq .611$ ), thus confirming the internal validity of the factor. The items that make up this factor revealed that some respondents with problematic usage of m-recreation had continuously made



unsuccessful efforts to cut back on their excessive usage of mobile devices. The respondents admitted that they were not able to regulate their m-recreation engagements culminating into restlessness, depression, irritability, debts and lying (Aoki and Downes, 2003; Hooper and Zhou, 2007).

Factor four, labelled *critical mass* comprised seven variables and accounted for 3.8% of the variance in the study with an eigen value of 1.638. In addition, high factor loadings were obtained on this sub-scale ( $.595 \leq \text{CM factor loadings} \leq .793$ ) as well as high communalities ( $.543 \leq \text{CM communalities} \leq .655$ ), thus confirming the internal validity of the factor. Khalifa and Chen (2002) underscored that the presence of a sufficient critical mass in mobile technology platforms will most likely predict whether or not the individual will perform or not perform specific behaviour. This suggests that users will comply with specific technology acceptance behaviour in line with the expectations of significant referent groups that include family, peers, authority figures and media personalities (Yang and Choi, 2001).

Factor five, labelled *quality of life* comprised four variables and accounted for 3.2% of the variance in the study with an eigen value of 1.037. In addition, high factor loadings were obtained on this sub-scale ( $.502 \leq \text{QOL factor loadings} \leq .765$ ) as well as high communalities ( $.428 \leq \text{QOL communalities} \leq .602$ ), thus confirming the internal validity of the factor. The respondents conceded that participating in mobile-device recreational activities enhanced their physical well-being through improved feelings of self-worth, reliance, confidence and personal growth. Similarly, some respondents found mobile-device recreation to be a unique refuge for relieving stress after a difficult day. However, extended hours of mobile screen time can also be one of the major contributing factors in an overall sedentary lifestyle, which can lead to a wide variety of health problems stemming from a lack of exercise and a lack of time spent outdoors.

### 3.3. Reliability of the study

When assessing scale reliability, Hair *et al.* (2010) suggested that; Cronbach's alpha coefficients of less than .50 are deemed unacceptable; those of between .50 and .69 are considered as being adequate; whereas those above .70 are regarded as being acceptable. The sub-scale reliability values ranged between .796 and .899 (female users) and .708 and .869 (male users) as depicted on Table 2. Moreover, a Cronbach alpha coefficient of .789 was recorded on the entire m-recreation scale, indicating high internal consistency among the scale items.

Table 2: Reliability of the m-recreation participation factors

		Technology Enjoyment	Dependency	Addiction	Critical Mass	Quality of Life
<b>Number of items</b>		<b>6</b>	<b>5</b>	<b>7</b>	<b>7</b>	<b>4</b>
Female	$\alpha$	.899	.857	.796	.865	.861
Male	$\alpha$	.869	.708	.723	.800	.803

### 3.4. Validity of the study

Initially, qualitative personal interviews (de-briefing session) were conducted so as to ascertain the content validity of the study. Content validity measures the extent to which each identified construct was conceptually consistent with the definition of a variable (Welman and Kruger, 2001). The responses from two Sports and Recreation professionals who were consulted led to some changes on the wording, order and layout of the questionnaire, consistent with the research objectives. The use of experts as judges of a scale's domain is acceptable in research (Zikmund and Babin, 2007). The modified instrument was then pre-tested on a conveniently selected sample of 40 respondents after which, there were no substantive concerns and the questionnaire was deemed suitable for final administration. The multiple phases of instrument development resulted in a significant degree of refinement and restructuring of the questionnaire, as well as the establishment of the *prima facie* validity of the study measures (Malhotra, 2010).

Exploratory factor analysis was conducted with a view to establish construct validity of the scale. The factor structure showed absence of cross-loadings thus providing evidence of discriminant validity (items loading on each construct were theoretically dissimilar from those loading on the other constructs) as suggested by Malhotra (2010). Furthermore, convergent validity was ascertained through the moderate to strong correlation results among the dimensions. Finally, the high Cronbach's alpha coefficient values for the entire scale (>0.70) reflects the high degree of cohesiveness among the variables, serving as an indirect indicator of convergent validity (Welman and Kruger, 2001).

### 3.5. Correlations: Mobile-device recreation factors and quality of life

Pearson's non-parametric correlation coefficients were computed to identify the possible existence of significant relationships between the four identified mobile-device recreation dimensions, and to describe the strength and direction outcome of the relationship with quality of life among the respondents. Table 3 reports the results.

Table 3: Correlation analysis (M-recreation factors with quality of life)

Factors	Technology enjoyment	Dependency	Addiction	Critical mass	Quality of life
Technology enjoyment	1.000				.511**
Dependency	.351*	1.000			-.213
Addiction	.320	.244	1.000		-.462**
Critical Mass	.106	.044	-.064	1.000	.296
QOL	.511**	-.213	-.462**	.296	1.000
<b>** Correlation is significant at the 0.01 level (2-tailed). *Correlation is significant at the 0.05 level (2-tailed).</b>					

Positive, strong correlation coefficients were recorded between m-recreation technology enjoyment ( $r=.511$ ;  $p<0.01$ ) and enhanced quality of life. Similarly, positive and moderate correlation coefficients were established on the critical mass factor ( $r= 0.296$ ;  $p<0.05$ ) with quality of life. These results imply that

the higher the prevalence of fun elements and extensive participation of referent groups along mobile platforms, the higher will be the general quality of life. In support, Kaplan (2006) highlighted that the likelihood of depression was reduced by the size of someone's social network and how often they interacted with friends during Internet-enabled mobile device recreation activities. Notwithstanding this, negative, moderate and significant correlations were established on the dependency ( $r=-.213$ ;  $p<0.05$ ) and addiction ( $r=-.462$ ;  $p<0.01$ ) factors with quality of life, which is indicative of the negative consequences of obsessive and compulsive behaviour on the general quality of life among South African.

### 3.6. The influence of m-recreation dimensions on quality of life (male and female sample groups)

Independent t-tests were computed in order to explore the possible existence of any gender-based differences in the samples along the identified m-recreation dimensions.

Table 4: Results of the Independent t-tests

		Enjoyment	Dependency	Addiction	Critical mass
<b>Mean</b>	Males	4.81	3.78	5.22	4.49
<b>SD</b>	(n=128)	.70	.97	.88	.77
<b>Mean</b>	Females	4.97	4.95	5.63	3.16
<b>SD</b>	(n=141)	1.03	.92	.87	.72
<b>T-test</b>	t-value	.346	.779	.841	.123
<b>Statistical Significance</b>	Sig (p-Value)	.897	.027*	.134	.000**
<b>Practical effect</b>	Cohen's <i>d</i>	.009	.576	.095	.303
		None	Large	None	Medium

1. \*\* Significance at  $p<0.01$  and \* Significance at  $p<0.05$ .
2. Minimum value (1= strongly disagree) and Maximum Value (7=strongly agree)
3. Cohen's *d* measure indicates practical significance (relationship with gender)

Table 4 illustrates the descriptive statistics (means and standard deviation) and statistical differences (t-tests, *p*-values) of each m-recreation factor. In addition, to assess the size of the correlation coefficients, qualitative judgements were made by computing Cohen's D-statistic leading to a measure of the practical significance and effect size of the association. The following guideline, as suggested by Cohen (1988) was followed:

- $d= .10$  to  $.29$  (small effect)
- $d= .30$  to  $.49$  (medium effect)
- $d= .50$  and greater (large effect)

#### 4. Discussion

Regarding the technology enjoyment dimension, no statistical differences were observed among male and female respondents in the sample ( $t=.346$ ;  $p=.897$ ), implying that both male and female respondents share similar views regarding the contribution of m-recreation technology enjoyment towards enhanced quality of life.  $H_1$  is therefore, rejected in this study. Furthermore, no practical significance was observed on the result as indicated by a small effect size ( $d=0.009$ ). Positive correlations confirmed the existence of a direct relationship between enjoyment and quality of life ( $r=.511$ ;  $p<0.01$ ) which provided empirical support for the validity of this dimension as a salient antecedent towards mobile-device recreation. Respondents reported that in their usage of mobile devices for recreation purposes, they are driven by the desire for fun, excitement, pleasure and enjoyment. This is consistent with the results of Bruner and Kumar (2005) and Kaplan (2011) who reported that the respondents who participated in their study acquired positive forms of internal gratification whilst using their mobile devices. Interestingly, statistical significance was observed among male and female respondents in the sample regarding the dependency factor ( $t=.779$ ;  $p=.027$ ). Relatedly, female respondents reported a higher mean score value ( $\bar{x} = 4.95$ ;  $SD = .92$ ) as compared to their male counterparts ( $\bar{x} = 3.78$ ;  $SD = .97$ ); thus signifying greater inclination towards impulsive participation on m-recreation platforms by women. Furthermore, large practical effect was observed along the dependency factor ( $d = .576$ ). Moreover, there were negative but significant correlations between dependency with quality of life ( $r=-.213$ ;  $p<0.05$ ), which suggested that as users became increasingly dependent on m-recreation; this could inadvertently have negative results on life quality.  $H_2$  is therefore, accepted in this study. These results further provided empirical support on those aspects related to compulsive use of mobile devices for recreation such as lack of control and financial indebtedness, which are often noticeable among users.

Regarding the addiction dimension, no statistical differences were observed among male and female respondents in the sample ( $t=.841$ ;  $p=.134$ ), implying that both male and female respondents share similar views regarding the subsequent addictive predispositions owing to augmented participation in m-recreation. Furthermore, a small effect size ( $d =0.095$ ) indicating no practical significance of this result, was observed.  $H_3$  is therefore, rejected in this study. Related to this finding were the negative but significant correlations between addiction and quality of life ( $r=-.462$ ;  $p<0.01$ ), which suggested that addictive and fixated behaviour that is associated with participation in m-recreation could inadvertently have negative results on the life quality of different individuals who may be pursuing a sedentary lifestyle. Madrid (2003) asserts that addictive tendencies are evident while utilising mobile devices for recreation. In support, Wilska (2003:451) found that mobile-device usage for recreation is highly addictive since users become overly reliant on the devices in an effort to maintain a certain status symbols among peers (Cassidy, 2006). Previous scholars found a significant correlation between technology addiction and negative psychological states such as loneliness, depression and compulsive behavior (Young, 2004). Kraut *et al.* (1998) claimed that pathological use of mobile-device technologies for leisure and recreation reduces the individual's social implication in the real world and as a

consequence, his or her psychological well-being. However, as Orford (2001) warned technology addictions often degenerate into adverse consequences such as distraction in the daily lives of users. Paradoxically, m-recreation produces the kind of isolation, loneliness and depression the individual wants to ease by connecting to their device. This has prompted researchers to label the mobile phone as 'the biggest non-drug addiction of the 21st century' (Shambare *et al.*, 2012:573-574). Relatedly, spending a great deal of time and money in virtual activities may also reduce the individual's dedication to other social, academic or work activities and therefore produce an impairment in his or her performance.

Regarding the critical mass factor, statistically significant differences were noted between male and female respondents ( $t=1.23$ ;  $p=.000$ ). Males reported a higher mean score value ( $\bar{x} = 4.49$ ;  $SD = .77$ ) as compared to their female counterparts ( $\bar{x} = 3.16$ ;  $SD = .72$ ), thus signifying greater inclination for m-recreation participation that is largely driven by the presence of an online community among men. In addition, medium practical effect size was observed along the critical mass dimension ( $d = .303$ ).  $H_4$  is therefore, accepted in this study. However, the positive and moderate correlation coefficients that were established between the critical mass factor with quality of life ( $r= 0.296$ ;  $p<0.05$ ) indicated factor convergence. The significant disparities regarding the perceptions of the male and female respondents regarding the influence of critical mass and reference group formation may perhaps be due to the fact that, males generally utilise a collectivism-based approach to participate in online recreation. In support, Venkatesh *et al.*, (2003:452) as well as Srivastava (2005) stated that males were more susceptible to having their social perceptive view being defined by other reference groups, prior to performing the specific behaviour in question. In their quest to maintain a harmonious relationship with their referents, male participants have demonstrated higher cohesiveness, even against their own feelings and beliefs, with a view to maintain group social status (Li *et al.*, 2005; Hooper and Zhou, 2007). This suggests that the influence played by friends, colleagues, family members and celebrities should never be underestimated with regard to shaping the usage of mobile devices for recreation among the millennial generation. However, these findings still need to be explored further.

## **5. Conclusions, limitations and implications for future study**

The purpose of this paper was to demonstrate how the Internet and mobile device based technology enables business owners to enter market places that were heretofore unavailable or unprofitable. In a society where affluence continues to grow and personal expenditure is on a trajectory, consumers are no longer constrained to outdoor-based recreation. The results of this study, through an initial exploratory factor analysis procedure, revealed that mobile-device recreation has led to the establishment of four dimensions that are critical towards enhancing the active participation of both male and female users in m-recreation. Within the same vein, moderate to strong, yet significant, relationships were established between technology enjoyment (positive relationship), dependency (negative relationship), addiction (negative relationship) and critical mass (positive relationship), with life quality among the users. In addition, statistically significant differences were noted between male and female user groups along the dependency and critical mass

dimensions. Technology has influenced younger generations in various areas of social life, including the nature of work and education, thus new, fulfilling variations of solving individuals' desire for recreation need to be developed. The development of m-recreation as a business arena, challenges leisure service programmers to provide a counter balance by developing new sustainable paradigms in this high-tech era. Further studies could assist to develop a more structured logical base on the proposed argument, thus strengthening the m-recreation knowledge base.

The findings of the study constitute an important source of knowledge and information on issues pertaining to the usage of mobile hand-held devices as recreational platforms among youths. However, the study has a limitation in that it utilises a sample size of 269 respondents, based in Southern Gauteng province only, in South Africa. This implies that caution must be exercised when generalising the results to other geographical locations and contexts. Moreover, the study did very little to specify which type of recreation respondents were engaged in. However, the findings of this study may provide a solid knowledge base for profiling and segmenting m-recreation users who are influenced by specific psychographic motives. This study can also be used to expand the theoretical base regarding the development of a valid measure of m-recreation, which possesses cultural invariance.

## References

- Abdelkarim, A.A., Nasereddin, H.H.O. (2010), Mobile commerce. *Journal of Mathematics and Technology*, (4), pp. 51-56.
- Alla, J.B., Olubayo-Fatiregun, M.A., Adeniran, S.A. (2007), Leisure: an escape route from work-related stress among lecturers, bankers and hospital workers in Ile-Metropolis, Nigeria. *African Journal for Physical, Health Education, Recreation and Dance*, 13(1), pp. 91-102.
- All Media and Product Survey report (AMPS) (2008), Cellphone usage in South Africa. Eighty 20 consumer information portal. Available online: [http://www.eighty20.co.za/databases/fad/fad\\_archive.cgi?wk=2008-41](http://www.eighty20.co.za/databases/fad/fad_archive.cgi?wk=2008-41). Accessed on 15<sup>th</sup> August 2013.
- Aoki, K., Downes, E.J. (2003), An analysis of young people's use of and attitudes toward cell phones. *Telematics Information Journal*, 20(4), pp. 349-364.
- Avkiran, N.K (1994), Developing an instrument to measure customer service quality in branch banking. *The International Journal of Bank Marketing*, 12(6), pp.10-18.
- Bialeschki, M.D. (1990), The feminist movement and females' participation in physical activity. *Journal of Physical Education, Recreation and Dance*, 61(1), pp. 44-47.
- Bianchi, A., Phillips, J.G. (2005), Psychological predictors of problem mobile phone use. *Cyber Psychology and Behavior*, 8(1), pp. 39-51.
- Bicen, H., Cavus, N. (2010), The most preferred network sites by students. *Procedia Social and Behavioural Science Journal*, 2(2010), pp. 5864-5869.

- Billieux, J.L., Van Der Linden, M., Rochat, L. (2008), The role of impulsivity in actual and problematic use of the mobile phone. *Applied Cognitive Psychology Journal*, 22(1), pp. 1195-1210.
- Bosshart, L., Hellmüller, L. (2009), Pervasive entertainment, ubiquitous entertainment. *Communication Research Trends*, 28(2), pp. 1-25.
- Boyd, D.M., Ellison, N.B. (2007), Social network sites: definition, history, and scholarship. *Journal of Computer-Mediated Communication*, 13(1), pp. 210-230.
- Bruner, G.C., Kumar, A. (2005), Explaining consumer acceptance of handheld Internet devices. *Journal of Business Research*, 58(1), pp. 553-538.
- Burke, L.J. (1996), Securing life through technology acceptance: The first six months after transvenous internal cardioverter defibrillator implantation. *Heart and Lung: The Journal of Acute and Critical Care*, 25(5), pp. 352-366.
- Burns, E. (2005), Teen, college students are most active cell phone users. Available online: [www.clickz.com/3530886](http://www.clickz.com/3530886). Accessed on 5<sup>th</sup> October 2013.
- Cant, M.C., Machado, R. (2005), *Marketing success stories*. 5th ed. Oxford, Cape Town, South Africa.
- Cassidy, S. (2006), Using social identity to explore the link between a decline in adolescent smoking and an increase in mobile phone use. *Health Education*, 106, pp. 238-250.
- Cawley, A., Hynes, D. (2010), Evolving mobile communication practices of Irish teenagers. *Aslib Proceedings, New Information Perspectives*, 62(1), pp. 29-45.
- Chiu, S-I., Hong, F-Y., Chiu, S-L. (2013), An analysis on the correlation and gender difference between college students' Internet addiction and mobile phone addiction in Taiwan. *ISRN Addiction*, 2013(360607): doi:10.1155/2013/360607.
- Choi, Y.K., Hwang, J.S., McMillan, S.J. (2008), Gearing up for Mobile Advertising: A cross-cultural examination of key factors that drive mobile messages home to consumers. *Psychology and Marketing Journal*, 25(8), pp. 756-768.
- Chow, S.L., Leung, G.M., Ng, C., Yu, E. (2008), A screen for identifying maladaptive Internet use. *International Journal of Mental Health and Addiction*, 7, pp. 324-332.
- Dhurup, M., Surujlal, J. (2009), Social support for health related leisure activity of the elderly and the relationship with health status and life satisfaction. *African Journal for Physical, Health Education, Recreation and Dance*, September (supplement), pp. 16-32.
- Dimmick, J., Feaster, J.C., Hoplamazian, G.J. (2011), News in the interstices: The niches of mobile media in space and time. *New Media and Society*, 13(1), pp. 23-39.
- Dlodlo, N., Mahlangu, H.B. (2013), Usage of mobile devices for recreation among the millennial generation. *African Journal for Physical Health Education, Recreation and Dance*, 19(4/2), pp. 874-890.
- Donner, J. (2008), Research Approaches to Mobile Use in the Developing World: A Review of the Literature. *The information Society*, 24(4), pp. 140-159.

- Edgington, C.R., Hanson, C.J., Edgington, S.R. (1992), *Leisure programming: concepts, trends and professional practise*. (2<sup>nd</sup> ed). WC Brown publishers: USA.
- Elphick, K. (2007), The role of mobile phone web utilisation in creating economic growth in South Africa. MBA Dissertation. University of Pretoria, South Africa.
- Floyd, F.J., Widaman, K.F. (1995), Factor analysis in the development and refinement of clinical assessment instruments. *Psychological Assessment*, 7(3), pp. 286-299.
- Fulk, J. (1993), Social Construction of Communication Technology, *Academy of Management Journal*, 36(5), pp. 921-950.
- Gao, T.T., Sultan, F., Rohm, A.J. (2010), Factors influencing Chinese youth consumers' acceptance of mobile marketing. *Journal of Consumer Marketing*, 27 (7), pp. 574-583.
- Griffiths, M.D. (1998), Internet addiction: does it really exist? In J. Gackenbach, J. (Ed.), *Psychology and the Internet: intrapersonal, interpersonal and transpersonal applications* (Pp. 61-75). Academic Press, New York.
- Hair, J.F., William, C.B., Babin, B.J., Anderson, R.E. (2010), *Multivariate data analysis*. Prentice Hall, Englewood Cliffs, New Jersey.
- Han, J.L., Hur, G.H. (2004), Construction and validation of mobile phone addiction scale. *Korean Journal of Journalism and Communication Studies*, 48(1), pp. 138-165.
- Hanley, A., Wilhelm, M.S. (1992), Compulsive buying: An exploration into self-esteem and money attitudes. *Journal of Economics and Psychology*, 13(5), pp. 5-18.
- Hodge, J. (2005), Tariff Structures and Access Substitution of Mobile Cellular for Fixed Line in South Africa. *Telecommunications Policy*, 29(7), pp. 493–505.
- Hooper, V., Zhou, Y. (2007), Addictive, dependent, compulsive? A study of mobile phone usage. Conference Proceedings of the 20th Bled eConference eMergence: Merging and Emerging Technologies, Processes, and Institutions held in Bled, Slovenia, June 4 – 6.
- Hsu, C.L., Lu, H.P. (2004), Why do people play on-line games? An extended TAM with social influences and flow experience. *Journal of Information and Management*, 41(1), pp. 853-868.
- Hutchinson, J.T. (1951), A Realistic Approach to Education for Recreation. *The High School Journal*, 34 (2), pp. 37-42.
- Igarashi, T., Motoyoshi, T., Takai, J., Yoshida, T. (2008), No mobile, no life: Self-perception and text-message dependency among Japanese high school students. *Computers in Human Behavior*, 24(5), pp. 2311-2324.
- International Telecommunications Union (ITU) (2011), Yearbook of statistics: Telecommunication services, 1990–1999. Geneva. Available online: <http://www.itu.int.pdf>. (Accessed on 30/09/2011). In brief: digital broadcasting goes global by 2015. Accessed on 16<sup>th</sup> August 2013.
- James, D., Drennan, J. (2005), *Exploring addictive consumption of mobile phone technology*. Paper presented at the Australian and New Zealand Marketing Academy conference, Perth, Australia.



- Kaplan W. A. (2006), Can the ubiquitous power of mobile phones be used to improve health outcomes in developing countries? *Globalisation and Health Journal*, 2(9), pp. 1-14.
- Kaiser, H.F. (1956), A second generation little jiffy. *Psychometrika*, 35, pp. 401-415.
- Kaplan, A.M. (2011), If you love something, let it go mobile: Mobile marketing and mobile social media 4x4. *Business Horizons*, 93(8), pp. 1-11.
- Kraut, R., Patterson, M., Lundmark, V., Kiesler, S., Mukopadhyay, T., Scherlis, W. (1998), Internet paradox: A social technology that reduces social involvement and psychological well-being? *American Psychologist*, 53(9), pp.1017-1031.
- Kumar, A., Lim, H. (2008), Age differences in mobile service perceptions: comparison of Generation Y and baby boomers. *Journal of Services Marketing*, 22 (7), pp. 568-577.
- Leung, L. (2007), Leisure boredom, sensation seeking, self-esteem, addiction symptoms and patterns of cell phone use. In E. A. Konijn, M. A. Tanis, S. Utz and A. Linden. (Eds.), *Mediated interpersonal communication* (pp 359-381). Lawrence Erlbaum Associates, USA.
- Leung, L., Wei R. (2000), More than just talk on the move: uses and gratifications of the cellular phone. *Journalism and Mass Communication Quarterly*, 77(2), pp. 308-321.
- Li, D., Chau, P.Y.K., Lou, H. (2005), Understanding Individual Adoption of Instant Messaging: An Empirical Investigation. *Journal of the Association for Information Systems*, 6(4), pp. 102-129.
- Lin, S.S. J., Tsai, C-C. (2002), Sensation seeking and Internet dependence of Taiwanese high school adolescents. *Computers in Human Behavior*, 18, pp. 411-426.
- Ling, R. (2000), We will be reached: The use of mobile telephony among Norwegian youth. *Journal of Information Technology and People*, 13(2), pp. 102-120.
- Liu, F.S. (2010), Wired for fun: Narratives from members of China's e-generation. *Young: Nordic Journal of Youth Studies*, 19(1), pp. 69-89.
- Livingstone, S. (2008), Taking risky opportunities in youthful content creation: teenagers' use of social networking sites for intimacy, privacy and self-expression. *New Media Society*, 10(3), pp. 393-411.
- Lou, H., Luo W., Strong, D. (2000), Perceived Critical Mass Effect on Groupware Acceptance. *European Journal of Information Systems*, 9(2), pp. 91-103.
- Madrid, A (2003), Mobile phones becoming a major addiction [Online]. Available online: <http://www.smh.com.au/articles/2003/12/10/1070732250532.html?from=storyrhs.html>. Accessed on 15<sup>th</sup> September 2013.
- Malhotra, N.K. (2010), *Marketing research, an applied orientation*. Eaglewood Cliffs, Prentice-Hall, New Jersey, USA.
- Markus, M.L. (1987), Toward a Critical Mass Theory of Interactive Media: Universal Access, Interdependence and Diffusion. *Communication Research*, 14(5), pp. 491-511.
- Mclaren, A, (2007), Online intimacy in a Chinese setting. *Asian Studies Review*, 31(4), pp. 409-22.

- Mence, V.H. (2003), The relation between everyday activities and successful aging: A 6-year longitudinal study. *Journal of Gerontology, Series B: Psychological Sciences and Social Sciences*, 58(1), pp. 74-82.
- Morahan-Martin, J., Schumacher, P. (2000), Incidence and correlates of pathological Internet use among college students. *Computers in Human Behavior*, 16, pp. 13-29.
- Murphy, J.F. (1974), *Concepts of leisure: Philosophical implications*. Eaglewood Cliffs, Prentice-Hall, New Jersey, USA.
- Neumeyer, M., Neumeyer, E. (1958), *Leisure and recreation*. Ronald Press, New York.
- Noble, S.M., Haytko, D.L., Phillips, J. P. (2009), What drives college-age Generation Y consumers? *Journal of Business Research*, 62(6), pp. 617-628.
- Nolan, V.T., Surujlal, J. (2009), Assessment of working women's perception and pursuit of recreation. *African Journal for Physical, Health Education, Recreation and Dance*, September (supplement), pp. 1-15.
- O'Guinn, T.C., Faber, R.J. (1989), Compulsive Buying: A Phenomenological Exploration. *Journal of Consumer Research*, 16(2), pp. 147-150.
- Oliver, P.E., Marwell, G., Teixeira, R. (1985), A Theory of the Critical Mass. Interdependence, Group Heterogeneity, and the Production of Collective Action, *American Journal of Sociology*, 91(3), pp. 522-556.
- Orford, P. (2001), *Excessive appetites: A psychological view of addictions* (2<sup>nd</sup> ed.). Chichester, Wiley Publishing House, United Kingdom.
- Ondrus, J., Pigneur, Y. (2007), Towards a holistic analysis of mobile payments: A multiple perspectives approach. *Electronic Commerce Research and Applications*, 5(3), pp. 246-257.
- Partarelli, M.E., Browne, B. (2002), Confirmatory factor analysis of Internet use and addiction. *CyberPsychology and Behavior*, 5(3), pp. 53-64.
- Potgieter, F. (2014), The mass market engages with mobile: Marketing Mobile Association. Available online: [www.bizcommunity.com/Print.aspx?Accessed](http://www.bizcommunity.com/Print.aspx?Accessed) on 12 January 2014.
- Ray, C.M., Sormunen, C., Harris, T.M. (1999), Men's and women's attitudes toward computer technology: a comparison. *Information, Technology, Learning and Performance Journal*, 17(1), pp. 1-8.
- Salo, J., Karjaluoto, H. (2007), Mobile games as an advertising medium: Towards a new research agenda. *Innovative Marketing Journal*, 3(1), pp. 71-84.
- Schiffman, L.G., Kanuk, L.L. (2010), *Consumer behaviour*. (10th ed.), Prentice Hall, New Jersey, USA.
- Schiano, D.J., Elliot, A.M.E., Bellotti, J. (2007), A Look at Tokyo Youth at Leisure: Towards the Design of New Media to Support Leisure Outings. *Journal of Computer Supported Cooperative Work*, 16, pp. 45-73.
- Shaffer, H.J. (1996), Understanding the means and objects of addiction: Technology, the Internet and gambling. *Journal of Gambling Studies*, 12, pp. 461-469.
- Shambare, R., Rugimbana, R., Zhoua, T. (2012), Are mobile phones the 21st century addiction? *African Journal of Business Management*, 6(2), pp. 573-577.

- Shaw, M., Black, D.W. (2008), Internet addiction: Definition, assessment, epidemiology and clinical management. *CNS Drugs*, 22(5), pp. 353-365.
- Soe, L., Markus, M.L. (1993), Technological or social utility? unraveling explanations of email, vmail and fax use. *The Information Society*, 9(3), pp. 231-236.
- Sports Council Report (1969) *Professional training for recreation Management* (Chairman, D. D. Molyneux), Sports Council, London, United Kingdom.
- Srivastava, L. (2005), Mobile phones and the evolution of social behaviour and Information Technology, 24 (2), pp. 111-129.
- Surujlal, J., Dhurup, M. (2009), Parental involvement in recreational activities of children with intellectual disabilities: A case study of the Thabo Vuyo School for learners with special educational needs. *African Journal for Physical Health Education, Recreation and Dance*, September (supplement), pp. 33-47.
- Torkildsen, G. (2005), *Leisure and recreation management*. Routledge, New York, USA.
- UNICEF, (2012), South African mobile generation Study on South African young people on mobiles. *Working Paper of the Division of Communication. Digital Citizenship Safety Project*, Division of Communication, Social and Civic Media Section, New York.
- Venkatesh, V. (2000), Determinants of Perceived Ease of Use: Integrating Control, Intrinsic Motivation and Emotion into the Technology Acceptance Model. *Information Systems Research*, 11(4), pp. 342-365.
- Venkatesh, V., Speier, C., Morris, M.G. (2002), User Acceptance enablers in individual decision making about technology: toward an integrated model, *Decision Sciences*, 33 (2), pp. 297-315.
- Walsh, S.P., White, K.M., Young, R.M. (2010), Needing to connect: the effect of self and others on young people's involvement with their mobile phones. *Australian Journal of Psychology*, 62(4), pp. 194-203.
- Welman, J.C., Kruger, S.J. (2001), *Research Methodology*, 2<sup>nd</sup> ed. Oxford University Press, United Kingdom.
- Wilska, T.A. (2003), Mobile phone use as part of young people's consumption styles. *Journal of Consumer Policy*, 26(4), pp. 441-463.
- Wolburg, J.M., Pokrywczynski, J. (2001), A psychographic analysis of generation Y college students. *Journal of Advertising Research*, 41(5), pp. 33-49.
- Yang, H-D., Choi, I. (2001), Revisiting Technology Acceptance Model with Social Influence Factors. *PACIS 2001 Proceedings*. Paper 35. [Online] Available online: <http://aisel.aisnet.org/pacis2001/35>. Accessed on 8<sup>th</sup> May 2013.
- Young, K.S. (2004), Internet addiction: A new clinical phenomenon and its consequences. *American behavioural scientist*, 48(4), pp. 402-415.
- Young, K.S. (2007), Cognitive behavior therapy with Internet addicts: treatment outcomes and implications. *Cyber Psychology and Behavior*, 10(5), pp. 671-679.
- Zhou, T. (2011), Examining the critical success factors of mobile website adoption. *Online Information Review*, 35(4), pp. 636-652.
- Zikmund, W.G., Babin, B.J. (2007), *Exploring marketing research*. (9th ed.). Thomson South-Western Publishers, USA.

## THE ASSESSMENT OF INCOME CONVERGENCE HYPOTHESIS IN ROMANIAN COUNTIES USING THE PANEL UNIT ROOT APPROACH

**Mihaela SIMIONESCU\***

Institute for Economic Forecasting of the Romanian Academy, Romania

**Abstract.** In this study, various panel unit root tests are applied in order to examine the real income convergence and catching-up process in the 42 counties (capital included in the sample) from Romania towards average national GDP per capita. According to MW Fischer and Levin, Lin and Chu (LLC) tests, there is evidence of conditional convergence for logarithm of GDP per capita in Romanian countries during 2000-2012, but the absolute convergence and the catching-up process were not present. These results make us to conclude that the particularities of each county significantly contribute to the GDP disparities between counties.

**JEL classification:** F14, C23, C33, C12

**Keywords:** convergence, unit root tests, GDP per capita, catching-up

### 1. Introduction

In many studies the convergence problem is analysed in the context of European Union (EU) members, one of the policy goals of the new countries from EU being to get high growth rates that allow the catching up to developed economies from Western Europe. This study is interested in another area to analyse the convergence, using the counties of an Eastern Europe country: Romania. The panel unit root tests are applied to evaluate if there is evidence of convergence and catching-up in the 42 Romanian counties, including the capital of Romania - Bucharest.

There are only few studies that examine the presence of catching-up process and the real convergence in different regions of a large area. The distinction between real and nominal convergence is rarely made.

Sigma and beta indicators are suitable indicators for measuring the convergence degree and the speed for the convergence realization. Beta parameter indicates the speed for convergence process when the sign is negative. Beta is an unsuitable indicator for the economic growth real convergence. There are few beta approaches: club convergence, absolute beta convergence, and conditional beta convergence. The sigma and beta tools are related and reciprocal checked. Club convergence supposes that the steady state varies across groups of relatively homogenous economies.

---

\* Corresponding author. 13, Calea 13 Septembrie, District 5, Tel: 004021.318.81.48, E-mail: mihaela\_mb1@yahoo.com

The indicator called sigma convergence is used to characterize the level of convergence by measuring the variance of GDP per capita for one year, utilizing the cross-section data about regions and countries. The indicator is relevant when comparisons are made.

The relation between initial level of income and subsequent growth constitutes the basis of the modern approach in growth literature. The beta-convergence approach states that two regions exhibit convergence if that with lower income grows faster than the other one. If the GDP per capita of the two regions converges to a steady-state value, we are in the situation described by absolute convergence that implies catching-up process (tendency of income equilibration). Conditional convergence allows for different levels of income per capita of the two regions, each of them going to its level.

This article is structured as it follows. After this introduction, a short literature review is made for field of testing the convergence. The methodological part presents a brief description of panel unit root tests. The next section analysed the empirical results of the convergence approach for Romanian counties. The last section concludes.

The introduction should also provide the hypothesis addressed or the motivation of the present study.

## **2. Literature review**

The classical approach is based on cross-country regressions for the mean of growth rate over a period and the initial GDP per capita and particularities of the country. This approach was considered unsuitable by Friedman (1992) and Quah (1993), who showed that the cross-country result of convergence speed is actually an illusion.

Another approach that was used by Bernard and Durlauf (1996), Evans and Karras (1996), Li and Papell (1999) supposes that the convergence hypothesis is tested using time series methods with a direct assessment of the persistence in convergence differences.

Bourdin (2013) took into account the local approach in measuring the regional disparities. The author proposed an index local de convergence applied for GDP per capita.

Mora (2014) analyzed the regional GDP growth using the post-Keynesian and neoclassical approaches. He predicted the economic convergence in GDP per capita and he also anticipated the convergence clubs using the endogenous growth and the spatial economy.

Beyond the cross-country regressions, there is also another very used approach: spatial econometrics. Cuadraro Roura (2001) emphasized that the differences between countries regarding legislation, countries policy, tax system have an important impact regarding the convergence and regional growth.

Studies regarding the convergence are made for developed, emerging and in transition countries.

Estrin et al. (2001) analysed the GDP per capita convergence for some transition economies with respect to EU average, the convergence assumption not being checked over the period from 1970 to 1998. Kocenda (2001) analysed the convergence in transition economies for macroeconomic variables using the panel unit root tests, finding obvious real convergence. The same technique has been

employed by Kutan and Yigit (2004) for testing nominal and real convergence for some transition economies that were candidates for EU, concluding that there is no income convergence of these countries with overall EU income. The real convergence was assessed for industrial output by Brada et al. (2003), obtaining evidence of convergence for EU and some candidates. Kaitila (2004) examined the sigma and the beta convergence, but also the impact of EU membership. According to the author, there are two periods of GDP per capita convergence across the EU15 countries: from 1960 to 1973 and from 1986 to 2001. Ranjpour and Zahra (2008) used the panel unit root approach in order to assess the income convergence across the 10 new countries from EU. In the period from 1995 to 2005 the convergence income was detected and the catching up process was present. Pastor and Serrano (2012) computed an annual beta convergence rate of 2% in current income for EU-27, anticipating a reduction of the inequality in permanent income.

Guetat and Serranito (2007) checked the convergence hypothesis in MENA region by applying the panel unit root tests. The conditional convergence was verified for most of the countries from MENA region. Musai and Mehrara (2013) analyzed the causality between economic growth and capital formation in the MENA region. The authors used the panel cointegration analysis and the panel unit root tests proving that the higher economic growth generates higher investment.

Drennan et al. (2004) applied unit root tests for checking sigma income convergence across US metropolitan zones. The chronological series could be described like random walk with drift and the divergences between zones did not diminish.

BaafiAntwi (2010) assessed the convergence between Ghana and the Western Europe, obtaining a quite slow income convergence. The author showed that Ghana is not on a balanced growth path.

Rasmidatta (2011) verified if Thailand is in the process of convergence and catching up over time with respect to some developed countries like United States, England and Singapore. In the period from 1970 to 2010, the convergence hypothesis was not checked for Thailand. Gomez and Ventosa (2007) applied the time series approach to evaluate the trade convergence in 30 Mexican regions.

Ucar and Omay (2009) proposed unit root tests for nonlinear heterogeneous panels, the alternative assumption being an exponential smooth transition model. These tests were used to check the income convergence in OECD countries.

### 3. Methodological background

The null assumption of the unit root tests can be formulated as the existence of unit root (for example, the Dickey Fuller test) or the stationary assumption (for example, the KPSS test). In case that the auto-correlation is eliminated parametrically, Augmented Dickey Fuller (ADF) test is used and if the elimination is made non-parametrically, the Phillips-Perron test is applied. We start from ADF test regression:

$$\Delta x_{i,t} = \alpha_i + (\rho_i - 1) \cdot x_{i,t-1} + \sum_{z=1}^{l_i} \beta_{i,z} \Delta x_{i,t-z} + \varepsilon_{i,t} \quad (1)$$

or

$$\Delta x_{i,t} = \alpha_i + b_i \cdot x_{i,t-1} + \sum_{z=1}^{L_i} \beta_{i,z} \Delta x_{i,t-z} + \varepsilon_{i,t} \quad (2)$$

$i = 1, 2, \dots, N$  and  $T = 1, 2, \dots, T$

Under the unit root assumption, for all  $i$  we have that  $\rho_i = 1$  which implies that  $b_i = 0$ . For large  $T$ , this hypothesis is checked using t ratio for each  $b$  and the critical values. Levin et al. (2002) restricted the coefficients as homogenous for all panel's units (for any  $i$ ,  $b_i = b$ ).

$$\Delta x_{i,t} = \alpha_i + b \cdot x_{i,t-1} + \sum_{z=1}^{L_i} \beta_{i,z} \Delta x_{i,t-z} + \varepsilon_{i,t} \quad (3)$$

If  $T$  and  $N$  tends to infinity and the ratio  $\frac{\sqrt{N}}{T}$  goes to zero, the null hypothesis is that  $b=0$ , while the alternative assumption is that  $b < 0$  for any  $i$  from 1 to  $N$ . The coefficient homogeneity may introduce the homogeneity bias of the fixed effect estimator as Maddala and Wu (1999) showed. In the IPS test case  $b_i$  differs (Im et al., 2003), the average ADF statistics being computed. A statistic based on Fischer observation was proposed by Maddala and Wu (1999):  $-2 \sum_{i=1}^N \ln p_i$ . In this case  $p_i$  is the p-value associated to the  $i$ -th test. The null hypothesis supposes a null value for  $p_i$ , the statistic following a chi-square distribution with  $2 \cdot N$  degrees of freedom. If  $y_{i,t}$  ( $t=1, \dots, T$  and  $i=1, \dots, N$ ) is the log real GDP per capita of county  $i$  at moment  $t$  and  $\bar{y}_t$  is the mean of Romanian GDP per capita at moment  $t$  in logs.

If  $y_{i,t}$  ( $i=1, \dots, N$  and  $t=1, \dots, T$ ) is the log real GDP per capita in the county  $i$  at the moment  $t$  and  $\bar{y}_t$  is the average log real GDP per capita in Romania at the moment  $t$ , the convergence assumption testing implies checking the unit root for  $(y_{i,t} - \bar{y}_t)$  in the 42 counties including Bucharest (Evans and Karras, 1996). The following model is used to test the convergence:

$$\Delta(y_{i,t} - \bar{y}_t) = \alpha_i + b_i \cdot (y_{i,t-1} - \bar{y}_{t-1}) + \sum_{z=1}^{L_i} \beta_{i,z} \Delta(y_{i,t-z} - \bar{y}_{t-z}) + \varepsilon_{i,t} \quad (4)$$

Individual unit root tests have limited power. The power of a test is the probability of rejecting the null when it is false and the null hypothesis is unit root. Levin, Lin and Chu test assumes that each individual unit in the panel shares the same AR(1) coefficient, but allows for individual effects, time effects and possibly a time trend. Lags of the dependent variable may be introduced to allow for serial correlation in the errors. The test may be viewed as a pooled Dickey-Fuller test, or an Augmented Dickey-Fuller (ADF) test when lags are included, with the null hypothesis that of nonstationarity ( $I(1)$  behavior). After transformation by factors provided by LLC, the t-star statistic is distributed standard normal under the null hypothesis of nonstationarity. The Im-Pesaran-Shin (IPS) test is not as restrictive as the Levin-Lin-Chu test, since it allows for heterogeneous coefficients. However, the tests have little power if deterministic terms are included in the analysis. The Fisher-type test uses p-values from unit root tests for each cross-section i.a huge

advantage of this type of test is that the test can handle unbalanced panels. Furthermore, the lag lengths of the individual augmented Dickey-Fuller tests are allowed to differ.

#### 4. Evidence of convergence for Romanian counties

The yearly GDP in constant prices and the population number are provided by the National Institute of Statistics from Romania for each county. Calculations are made by the author in order to get the GDP per capita. The data series covers the period from 2001 to 2012. The Romanian counties are different from the point of GDP values. There are rich regions like Bucharest (the capital of Romania), Cluj, Constanța and Timiș and very poor counties like Covasna, Vaslui and Mehedinți. The degree of economic development is influenced by the number of inhabitants and surface and by the counties geographical, industrial and commercial perspective. For example, a low GDP was observed for Covasna, but it has a small number of inhabitants. Counties like Constanța, Brașov, Iași have a very developed tourism regarding the relief (sea, mountain) or the presence of numerous religious attractions (monasteries, churches) in the case of counties from the north of Moldavia.

According to 2011 census organized by National Institute of Statistics from Romania, the most populous county is Iași and the least is Covasna. There is a consistent trend between low GDP and rates of growth.

Figure 1: The individual evolution of the log of GDP per capita in the Romanian counties during 2000-2012

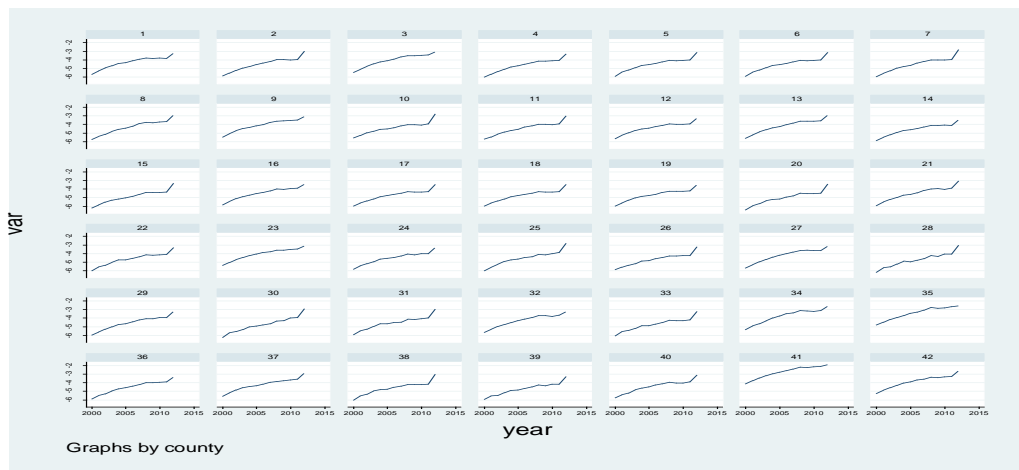

Source: author's graph

The individual evolution of the log of GDP per capita represented in the graph shows that there are not significant differences between the counties' GDP tendency of evolution. In 2010 a tendency of decrease was observed in all the regions because of the economic crisis started in 2009.



As the graph shows, there are many counties with close values of the log GDP per capita during 2000-2012. For Bucharest there is an obvious discrepancy of log of GDP per capita compared to the Romanian counties.

Figure 2: Average GDP rate and log of the initial GDP per capita in the Romania's counties

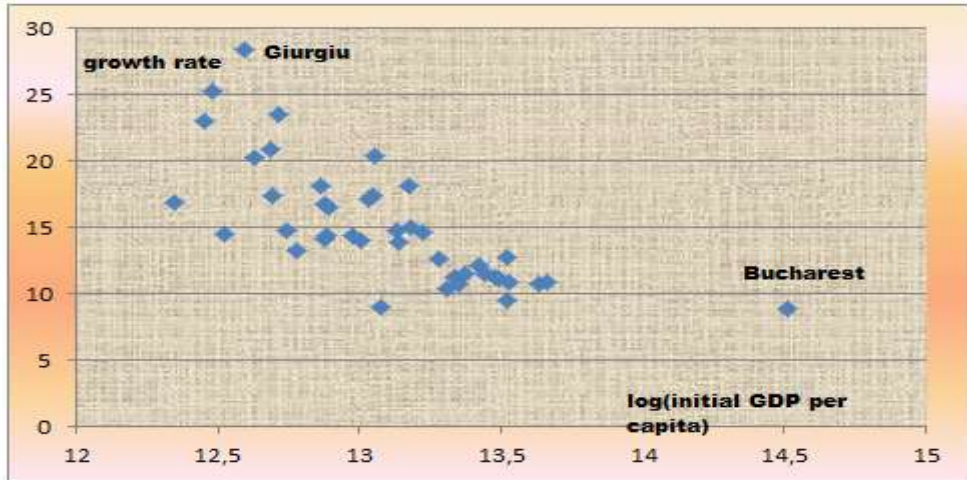

Source: author's graph

For Bucharest the variables presented different values compared to the other counties. The capital of Romania had the highest value for log of initial GDP per capita, but a very low growth rate. Giurgiu registered the maximum growth rate, but the log of initial GDP per capita is quite low.

The results of MW Fischer chi-square, Levin, Lin and Chu test(LLC) and Im, Pesaran and Shin test (IPS) are displayed in the following table for the convergence of the 42 cross-sections, the details being described in the Appendix. The null hypothesis is rejected at 5% significance level when LLC and MW tests are applied. However, according to IPS test, we do not have enough evidence to reject H0. So, there is evidence for conditional convergence in the Romanian counties. IPS has a little power in this case because the number of counties is relative large compared to the number of years in the mentioned period.

Table 1: The results of panel unit root tests for conditional convergence assumption (towards average Romania's GDP per capita)

Method	H0 (null hypothesis)	Statistic	Probability
Levin, Lin and Chu	Common unit root	-12.8856	0.000
Im, Pesaran and Shin	Individual unit root	1.2635	0.8968
MW Fischer chi-square	Individual unit root	10.1543	0.000

Source: author's computations

The absolute convergence hypothesis is checked by suppressing the intercept from the models associated to panel unit root tests. The results show clearly that the null hypothesis is not rejected at 5% level of significance. In other words, there is not significant absolute convergence towards the average GDP per capita of Romania and catching-up process does not exist in the 42 counties.

Table 2: The results of panel unit root tests for absolute convergence assumption (towards average Romania's GDP per capita)

Method	H0 (null hypothesis)	Statistic	Probability
Levin, Lin and Chu	Common unit root	7.9837	1.000
Im, Pesaran and Shin	Individual unit root	1.3514	0.9117
MW Fischer chi-square	Individual unit root	0.22	0.4129

Source: author's computation

All in all, the panel unit root tests showed that there is conditional convergence in Romanian counties, but not absolute convergence for logarithm of GDP per capita.

## 5. Conclusions

The purpose of this research is to provide information regarding regional convergence in Romanian counties, using as instruments the panel data unit root tests. In this study the real convergence was tested for the Romanian counties (42 cross-sections) to the Romanian average logarithm of GDP per capita using annual data from 2000 to 2012.

The application of various panel unit root tests reflected that the counties do not tend to move towards the Romanian average GDP per capita. However, the conditional convergence hypothesis was checked. The catching-up process is not existent in the Romanian counties, fact that implies an obvious economic diversity among counties. Even if the unit have been confronted with the same policy changes, there are particularities of each county that made the absolute convergence as non-significant.

The limit of this research is provided by the fact that the results might be contrary to those based on other methods. Each type of method has its specificity, following a certain perspective of the convergence process. Therefore, in order to have a multiple view of the convergence process, a future direction of research will suppose the computation of variability and inequality indicators for each county on the same horizon.

## APPENDIX

### The results of panel unit root tests

Levin-Lin-Chu unit-root test for var

---

Ho: Panels contain unit roots	Number of panels =	42
Ha: Panels are stationary	Number of periods =	13
AR parameter: Common	Asymptotics: root(N)/T -> 0	
Panel means: Not included		
Time trend: Not included		

ADF regressions: 1 lag

LR variance: Bartlett kernel, 7.00 lags average (chosen by LLC)

---

	Statistic	p-value
Unadjusted t	-13.4973	0.0000
Adjusted t*	-12.8856	0.0000

---

Im-Pesaran-Shin unit-root test for var

---

Ho: All panels contain unit roots	Number of panels =	42
Ha: Some panels are stationary	Number of periods =	13
AR parameter: Panel-specific	Asymptotics: T,N -> Infinity	
Panel means: Included	sequentially	
Time trend: Not included	Cross-sectional means removed	

ADF regressions: No lags included

---

	Statistic	p-value	Fixed-N exact critical values		
			1%	5%	10%
t-bar	-1.3462		-1.830	-1.740	-1.690
t-tilde-bar	-1.1747				
Z-t-tilde-bar	1.2635	0.8968			

---

Fisher-type unit-root test for var  
Based on augmented Dickey-Fuller tests

---

Ho: All panels contain unit roots	Number of panels =	42
Ha: At least one panel is stationary	Number of periods =	13
AR parameter: Panel-specific	Asymptotics: T -> Infinity	
Panel means: Included	Cross-sectional means removed	
Time trend: Not included	ADF regressions: 0 lags	
Drift term: Included		

---

		Statistic	p-value
Inverse chi-squared(84)	P	215.6150	0.0000
Inverse normal	Z	-7.7269	0.0000
Inverse logit t(214)	L*	-7.8660	0.0000
Modified inv. chi-squared Pm		10.1543	0.0000

---

P statistic requires number of panels to be finite.  
Other statistics are suitable for finite or infinite number of panels.

Fisher-type unit-root test for var  
Based on augmented Dickey-Fuller tests

---

Ho: All panels contain unit roots	Number of panels =	42
Ha: At least one panel is stationary	Number of periods =	13
AR parameter: Panel-specific	Asymptotics: T -> Infinity	
Panel means: Included		
Time trend: Not included	Cross-sectional means removed	
Drift term: Not included	ADF regressions: 0 lags	

---

		Statistic	p-value
Inverse chi-squared(84)	P	86.8518	0.3940
Inverse normal	Z	0.9024	0.8166
Inverse logit t(214)	L*	1.1290	0.8699
Modified inv. chi-squared	Pm	0.2200	0.4129

---

P statistic requires number of panels to be finite.

Other statistics are suitable for finite or infinite number of panels.

Im-Pesaran-Shin unit-root test for var

---

Ho: All panels contain unit roots	Number of panels =	42
Ha: Some panels are stationary	Number of periods =	13
AR parameter: Panel-specific	Asymptotics: T,N -> Infinity	
Panel means: Included	sequentially	
Time trend: Included	Cross-sectional means removed	

ADF regressions: No lags included

---

	Statistic	p-value	Fixed-N exact critical values		
			1%	5%	10%
t-bar	-1.4173		-2.480	-2.380	-2.330
t-tilde-bar	-1.1647				
Z-t-tilde-bar	1.3514	0.9117			

Levin-Lin-Chu unit-root test for var

---

Ho: Panels contain unit roots	Number of panels =	42
Ha: Panels are stationary	Number of periods =	13
AR parameter: Common	Asymptotics: N/T -> 0	
Panel means: Included		
Time trend: Included	Cross-sectional means removed	

ADF regressions: 1 lag

LR variance: Bartlett kernel, 7.00 lags average (chosen by LLC)

---

	Statistic	p-value
Unadjusted t	-8.1379	
Adjusted t*	7.9837	1.0000

---

## References

- BaafiAntwi, J. (2010), Ghana's Economic Growth in perspective: A time series approach to Convergence and Growth Determinants, MPRA Paper, 23455, pp. 2-72.
- Barro, R. J., Sala-i-Martin, X., Blanchard, O. J., Hall, R. E. (1992), Convergence across states and regions, *Brookings papers on economic activity*, 2(87), pp. 107-182.
- Bernard, A. B., Durlauf, S. N. (1996), Interpreting tests of the convergence hypothesis, *Journal of econometrics*, 71(1), pp. 161-173.
- Bourdin, S. (2013), Une mesure spatiale locale de la sigma-convergence pour évaluer les disparités régionales dans l'Union Européenne, *Region et Développement*, 3(37), pp. 1-18.
- Brada, J. C., Kutan, A. M. (2001), The convergence of monetary policy between candidate countries and the European Union, *Economic Systems*, 25(3), pp. 215-231.
- Brada, J. C., Kutan, A. M., Zhou, S. (2005), Real and monetary convergence between the European Union's core and recent member countries: a rolling cointegration approach, *Journal of Banking and Finance*, 29(1), pp. 249-270.
- Cuadrado-Roura, J. R. (2001). Regional convergence in the European Union: From hypothesis to the actual trends. *The Annals of Regional Science*, 35(3), 333-356.
- Drennan, M. P., Lobo, J., Strumsky, D. (2004), Unit root tests of sigma income convergence across US metropolitan areas. *Journal of Economic Geography*, 4(5), pp. 583-595.
- Estrin, S., Urga, G., Lazarova, S. (2001), Testing for ongoing convergence in transition economies, 1970 to 1998. *Journal of Comparative Economics*, 29(4), pp. 677-691.
- Evans, P., Karras, G. (1996), Convergence revisited, *Journal of monetary economics*, 37(2), pp. 249-265.
- Friedman, M. (1992), Do old fallacies ever die?, *Journal of Economic Literature*, 30(1), pp. 2129-2132.
- Gomez, M., Ventosa S. D. (2007), Trade liberalization and regional income convergence in Mexico: a time-series analysis, *School of Economics papers*, Universidad de Guanajuato.
- Guetat, I., Serranito, F. (2007). Income convergence within the MENA countries: A panel unit root approach, *The Quarterly Review of Economics and Finance*, 46(5), pp. 685-706.
- Im, K. S., Pesaran, M. H. Y. Shin, I. (1997), *Testing for Unit Roots in Heterogeneous Panels*, Cambridge: University of Cambridge, 456 pp.
- Im, K. S., Pesaran, M. H., Shin, Y. (2003), Testing for unit roots in heterogeneous panels, *Journal of econometrics*, 115(1), pp. 53-74.
- Kaitila, V. (2004), Convergence of Real GDP Per Capita in the EU15: How do the Accession Countries Fit In, *European Network of Economic Policy Research Institutes working paper*, 25, pp. 56-75.
- Kočenda, E. (2001), Macroeconomic convergence in transition countries, *Journal of Comparative Economics*, 29(1), pp. 1-23.

- Kutan, A. M., Yigit, T. M. (2004) Nominal and real stochastic convergence of transition economies, *Journal of Comparative Economics*, 32(1), pp. 23-36.
- Levin, A., Lin, C. F., James Chu, C. S. (2002) Unit root tests in panel data: asymptotic and finite-sample properties, *Journal of econometrics*, 108(1), 1-24.
- Li, Q., Papell, D. (1999), Convergence of international output time series evidence for 16 OECD countries, *International review of economics & finance*, 8(3), pp. 267-280.
- Maddala, G. S., Wu, S. (1999), A comparative study of unit root tests with panel data and a new simple test, *Oxford Bulletin of Economics and statistics*, 61(S1), pp. 631-652.
- Mora, T. (2014), Convergence Clubs and Spatial Externalities. Models and Applications of Regional Convergence in Europe, *Regional Studies*, 48(5), pp. 937-938.
- Musai, M., Musai, M. (2013), The Causality between Capital Formation and Economic Growth in MENA Region, *International Letters of Social and Humanistic Sciences*, 1(08), pp. 1-7.
- Pastor, J. M., Serrano, L. (2012), European integration and inequality among countries: a lifecycle income analysis, *Review of International Economics*, 20(1), pp. 186-199.
- Quah, D. T. (1996), Empirics for economic growth and convergence, *European economic review*, 40(6), pp. 1353-1375.
- Ranjpour, R., & Zahra, T. K. (2008), Evaluation of the income convergence hypothesis in ten new members of the European union: A panel unit root approach, *Panoeconomicus*, 55(2), pp. 157-166.
- Rasmidatta, P. (2011), The Relationship Between Domestic Saving and Economic Growth and Convergence Hypothesis: Case Study of Thailand.
- Ucar, N., Omay, T. (2009), Testing for unit root in nonlinear heterogeneous panels, *Economics Letters*, 104(1), pp. 5-8.

## **Acknowledgments**

This article includes some results from the study “Convergence in the European Union. Theory and applications”, part of the research programme for 2014 of the Institute for Economic Forecasting of the Romanian Academy, coordinated by Academician Lucian-Liviu Albu.

## **AN EMPIRICAL INVESTIGATION OF ENTREPRENEURIAL INTENTIONS AMONG BUSINESS STUDENTS OF PAKISTAN**

**Shahbaz HUSSAIN\***

University of Education, Pakistan

**Hafiza Hafsa NAYAB**

University of Education, Pakistan

**Farrukh SHAHZAD**

Lahore Leads University, Pakistan

**Zeeshan FAREED**

COMSATS Institute of Information Technology, Pakistan

**Zain ul ABIDAN**

University of Education, Pakistan

**Abstract.** Trends of small businesses and entrepreneurship are rapidly gaining popularity all over the world because these can contribute to economic uplift of any country. The aim of present study is to investigate the impact of personality traits on entrepreneurial intentions among business students of Pakistan. Different personality traits such as need for achievement, risk taking, internal locus of control, openness to experience, and extraversion have been taken as independent variables and entrepreneurial intentions have been taken as dependent variable. Sample of 350 business students has been chosen from 5 public universities of Pakistan by using cluster sampling approach. Data has been collected through structured questionnaire and analyzed by using AMOS 19 (Analysis of Moment Structures) software. Results of path analysis indicated that need for achievement, internal locus of control and openness to experience have significant impact on entrepreneurial intentions among business students of Pakistan. It has also been found that risk taking and extraversion does not have significant impact on entrepreneurial intentions among business students of Pakistan. It has been suggested that government should identify and train potential entrepreneurs to attain economic growth and reduce unemployment rate.

**JEL Classification:** M13, M19

**Keyword:** Entrepreneurial intentions, Extraversion, Internal locus of control, Need for achievement, Openness to experience

---

\* Corresponding author address, University of Education, Lahore (Multan Campus) Bosan Road Multan. *Tel:*+92-321-7090062, *Email:* rai\_shahbaz\_hussain@ue.edu.pk

## **1. Introduction**

World is experiencing economic downfall and many large organizations are shrinking their size to enhance business effectiveness. This has created employment uncertainty and made entrepreneurship a need of the hour. A lot of people are now thinking to own their business and “being their own boss”. The importance of entrepreneurship and small businesses has been discussed at different forums around the globe and different sectors of community are adopting entrepreneurship as their career in many developing and developed countries.

Small business owners or entrepreneurs can play a substantial role in economic growth and elevate economy by involving in business operations at micro level. Entrepreneurs bring innovation and change already set business patterns by bringing something new to market. A number of universities are providing entrepreneurial education to create entrepreneurial desires among students and are offering different courses of entrepreneurship. Despite of such a high emphasis on entrepreneurship and self-employment, not every human being thinks to be an entrepreneur. There are some characteristics that create desires among people to be self-employed and differentiate entrepreneurs from others. The desire to be self-employed and starting one’s own business are termed as entrepreneurial intentions.

Pakistan is a developing country and it has high rate of unemployment. A large number of students pass out every year but there are not enough job opportunities to accommodate such a large bulk of fresh graduates that’s why entrepreneurship is gaining popularity in this country also. Different educational institutions are moreover contributing in this respect by offering entrepreneurship education. In Pakistan there is a strong need to inquire that which factors really contribute in creating entrepreneurial intentions among people living here in order to respond to entrepreneurial trends and uplift of economy by reducing unemployment and through enhanced business transactions.

The intent of present study is to investigate impact of different personality traits on entrepreneurial intentions among business students in Pakistan. It will also inspect differences in entrepreneurial intentions on the basis of gender, educational qualification and city of origin. This study is quantitative in nature, sample will be chosen by using probability sampling and data will be collected with the help of structured questionnaire. For data analysis structural equation modeling technique will be applied by using Amos 19 software. The last section of the paper will cover findings, discussion, conclusion and recommendations.

## **Research Objectives**

The objectives of the study are:

- To investigate the impact of need for achievement on entrepreneurial intentions among business students of Pakistan
- To investigate the impact of risk taking on entrepreneurial intentions among business students of Pakistan
- To investigate the impact of internal locus of control on entrepreneurial intentions among business students of Pakistan



- To investigate the impact of openness to experience on entrepreneurial intentions among business students of Pakistan
- To investigate the impact of extraversion on entrepreneurial intentions among business students of Pakistan

## 2. Literature Review

Entrepreneurship provides new ways to innovation and creativity which provides new insights for doing business, creating new jobs and also contributes to increase the national wealth. Purpose of entrepreneurship is to discover new insights, finding gaps and searching new opportunities (Luca & Cazan, 2011).

In 1970's western countries experienced that large organizations were not contributing in reducing rate of unemployment as it was desired. During 1980's these countries also evidenced that large organizations were reducing jobs and laying off large number of employees as a part of their cost cutting strategies. In this time the developed countries realized importance of entrepreneurial intentions and small businesses proved that these are potential sources of elevating economy by creating new job opportunities. In the course of this time following theories about entrepreneurial intentions were emerged: Bird's (1988) theory of entrepreneurial intentions, Ajzen & Fishbein (1980) Theory of Reasoned Action and Ajzen's (1991) Theory of Planned Behavior. Ajzen (1991) based his Theory of Planned Behavior on his earlier concept Theory of Reasoned Action. In theory of Reasoned Action Ajzen & Fishbein (1980) stated that entrepreneurial intentions are based on individual's perception about suitability of career as entrepreneur. But in later version Ajzen (1991) proposed that entrepreneurial intentions are very crucial in making a decision of starting one's own business. Bagozzi & Bluedorn (1989) described that entrepreneurial intentions are very important factor in describing the succeeding intended behavior. Krueger, *et al.* (2000) further elaborated and stated that entrepreneurial intentions are the deliberate and planned decisions regarding start of new venture. Some individuals have the confidence and ability to start a new venture but they lack the entrepreneurial intentions to start a new venture. So it can be claimed that entrepreneurial intentions are the planned decisions regarding start of one's own business that differentiate entrepreneurs from non-entrepreneurs.

On important way of identifying entrepreneurial intentions is the trait approach which states that entrepreneurs have certain inherent psychological and God gifted characteristics (Fisher & Koch, 2008). According to Sommer and Haug (2011) and Gelderen, *et al.* (2008) personality traits are significant contributors of entrepreneurial intentions. The logic behind using personality traits to identify entrepreneurial intentions is as given by (Luca & Cazan, 2011) that certain personality traits affect individual's level of motivation to start something new and thus in turn affects entrepreneurial intentions. Therefore it can be claimed that certain personality traits affect individual's intention to start business.

Personality traits have been further categorized into broad and narrow approaches. Broad approach of personality traits includes Big-Five personality traits whereas narrow approach includes all personality traits other than Big-Five traits. Tett, *et al.* (2003) stated that it is important to identify which personality traits really contribute to entrepreneurial intentions. Therefore the present study will focus on both broad and narrow approach of personality traits to determine entrepreneurial intentions.

In narrow approach of personality traits, the most influential traits identified are need for achievement, risk taking propensity and internal locus of control. McClelland, (1961) given the concept of need for achievement and stated that it affects a person's level of motivation. Littunen (2000) stated that need for achievement pushes a person to pursue entrepreneurial actions. Other researchers have also concluded that need of achievement contributes in making decisions regarding start of business venture (Ward, 2005; Weitzel, *et al.*, 2010).

Kihlstrom. & J. (1979) proposed that risk taking is a basic characteristic of entrepreneur. Cramer, *et al.* (2002) further elaborated that risk taking propensity differentiates entrepreneurs from others. It has been recognized that tolerance of ambiguity and risk propensity play vital role in creating entrepreneurial intentions (Kickul & Gundry, 2002). According to Zhao, *et al.* (2010), to start a new business the most important is the ability to bear ambiguity and risk propensity. Caliendo *et al.* (2009, 2010) also reported that risk taking is an essential trait of entrepreneurs. Entrepreneurs are risk lovers and it is positively related to the intention of entrepreneur. But risk must be within certain limits as identified by Chell, *et al.* (1991).

Rotter (1966) stated that some individuals think that they are masters of their own fate. He termed this phenomenon as internal locus of control. Different researchers including Pandey and Tewary (1979), Brockhaus (1982), Brockhaus and Horowitz (1986), Begley and Boid (1987), Evans and Leighton (1989), (Perry, 1990) and Mueller and Thomas (2000), Beverland and Locksin (2001) and (Chell, 2008) investigated the impact of internal locus of control on entrepreneurial intentions and found that persons who make decisions in their own way and believe that what happens to them is just because of their own actions have more entrepreneurial intentions.

The Broad approach or Big-Five personality traits have been identified McCrae and John (1992). Big-Five personality traits are extraversion, emotional stability, openness to experience, agreeableness and conscientiousness. Some researchers have investigated impact of Big-Five personality traits on entrepreneurial intentions such as McCare (1987) and Zhao and Seibert (2006). It has been evidenced that among all Big-Five personality traits only extraversion and openness to experience were significantly contributing to entrepreneurial intentions.

In earlier studies it has been evidenced that some factors can create differences in entrepreneurial intentions of potential entrepreneurs such as Wang & Wong (2004) and Keong (2008) specified that gender affects the relation between personality traits and entrepreneurial intentions and that male students have more intentions to start their business than females. Souitaris (2007) stated that entrepreneurial intentions are also affected by business education. Students who have acquired the business education may have more entrepreneurial intentions than others.

Entrepreneurial intentions have also been investigated in Pakistan such as Ahmed, *et al.* (2010), Ahmad (2010), Ali, *et al.* (2011), Aslam, *et al.* (2012) and Tanveer, *et al.* (2013) examined the relation between certain personality traits and entrepreneurial intentions and concluded that in Pakistan there is a large bulk of potential entrepreneurs that can be developed and groomed by using appropriate measures.

### 3. Theoretical Framework

This study is aimed at investigating the impact of personality traits on entrepreneurial intentions among business students of Pakistan. Following section will cover theoretical framework and research model and hypotheses are a part of this section.

#### 3.1 Research Model

Figure-1 depicts research model of the study. On the left side of the model are different personality traits such as need for achievement, risk taking, internal locus of control, extraversion and openness to experience. These are taken as independent variables. On the right side is entrepreneurial intention that is the dependent variable. Although prior researches have been conducted on entrepreneurial intentions in the same context but the present study is novel in terms of the variables and the research model. This study will investigate the impact of both broad and narrow personality traits to depict entrepreneurial intentions.

Figure 1: Research Model

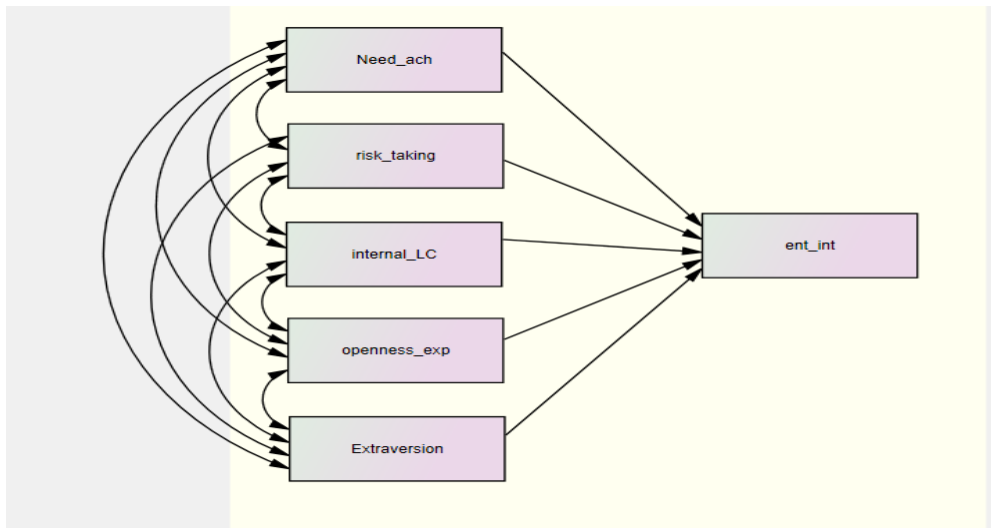

#### 3.2 Hypotheses

Previous research work provides evidence regarding impact of personality traits on entrepreneurial intentions. Previous literature provides us a base to develop different hypothesis.

Need for achievement and entrepreneurial intentions:

Need for Achievement as described by McClelland, (1961) creates desire and persistence among individuals to attain something. Littunen (2000), Ward, 2005 and Weitzel, *et al.*, 2010 investigated the relationship between need for achievement and entrepreneurial intentions and reported significant association. So based on the previous evidence it is assumed that:

**H1:** Need for achievement significantly affects entrepreneurial intentions among business students of Pakistan

Risk taking and entrepreneurial intentions:

Kihlstrom. & J. (1979) proposed that risk taking is essential trait of an entrepreneur. After that Cramer, *et al.* (2002), (Kickul& Gundry, 2002), Zhao, *et al.* (2010), Caliendo *et al.* (2009, 2010) and Chell, *et al.* (1991) reported significant impact of risk taking on entrepreneurial intentions. Therefore based on this evidence it is supposed that:

**H2:** Risk taking has significant impact of entrepreneurial intentions among business students of Pakistan

Internal locus of control and entrepreneurial intentions:

Rotter (1966) gave the concept of internal locus of control and proposed that some individuals have natural tendency to make decisions in their own way and assuming resulting success and failures as a result of their own actions. Different researchers including Pandey and Tewary (1979), Brockhaus (1982), Brockhaus and Horowitz (1986), Begley and Boid (1987), Evans and Leighton (1989), (Perry, 1990), Mueller and Thomas (2000), Beverland and Locksin (2001) and (Chell, 2008) investigated the impact of internal locus of control on entrepreneurial intentions and reported significant relation. Therefore it is assumed that:

**H3:** Internal locus of control has significant impact on entrepreneurial intentions among business students of Pakistan

Extraversion, openness to experience and entrepreneurial intentions:

McCrae and John (1992) identified that extraversion is the degree to which a person is communal and talkative. McCare (1987) and Zhao and Seibert (2006) stated that people having extraversion and openness to experience trait have more entrepreneurial intentions. Entrepreneurs have to deal with different stakeholders to carry out their business operations and they must be ready to experience new things therefore it is assumed that:

**H4:** Extraversion significantly affects entrepreneurial intentions among business students of Pakistan

**H5:** Openness to experience significantly affects entrepreneurial intentions among business students of Pakistan

#### **4. Research Methodology**

Methodology describes the process of research used in the study. It includes target population, sampling procedure and sample, data collection methods and procedures, and finally data analysis methods. Following are the details.

##### **Target population**

This study is aimed at investigating entrepreneurial intentions among business students of Pakistan but the target populations are the business students of public sector universities operating in Punjab. Punjab is the largest province of Pakistan

in terms of its population therefore it has been selected as target population because it has more generalizability.

**Sampling procedure and sample**

From 23 public sector universities of Punjab (Pakistan) we have selected a sample of 5 universities by using probability sampling approach. Instrument was distributed among 350 business students.

**Data Collection Method and Procedure**

Data collection method implied in the study is structured questionnaire. The researcher has personally visited 3 universities. In order to avoid biases and despite of directly going to classes for data collection, researcher conducted a meeting with relevant head of the departments and handed over the questionnaires to class lecturers. The class lecturers collected data and returned back the questionnaires immediately to the researcher. In remaining 2 universities questionnaires were sent by post and were returned back within one week. It has been observed that response rate was higher in the case where researcher personally administered questionnaire and data collection time was also lesser in this case. Overall 322 questionnaires were collected back so the total response rate is 92%.

**Data analysis method**

Data has been analyzed using structural equation modeling technique and AMOS 19 (Analysis of Moment Structures) software has been used for this purpose. The upcoming section will cover findings and discussions.

**5. Findings and Discussion**

Table 1 summarizes the results of reliability coefficients. The value of Chronbach alpha that is considered acceptable is 0.7. It has been shown that all variables are meeting and exceeding the criteria of reliability.

Table 1: Reliability Coefficients (Chronbach alpha)

<b>Need for achievement</b>	<b>0.905</b>
<b>Risk taking</b>	0.886
<b>Internal locus of control</b>	0.907
<b>Openness to experience</b>	0.917
<b>Extraversion</b>	0.889
<b>Entrepreneurial intentions</b>	0.907

Table 2 summarizes the results of descriptive statistics. Out of total 320 respondents, 59.4% respondents are male and 40.6% of the respondents are female. Similarly business graduates having different academic qualifications participated in survey. Among them 38.4% have bachelor business degree, 52.8% have MBA degree and remaining 8.8% are doing MS in business. Participants belong to different areas. Punjab (Pakistan) has 9 divisions. It has been observed

that participants are representing 8 out of 9 divisions. So again it is indicating a level of good generalizability. It has also been investigated that whether gender, academic qualification and area/division of origin affects entrepreneurial intentions? It has been found that all these three variables are not affecting entrepreneurial intentions.

Table 2: Data Frequency

Variable		Frequency	Valid Percent
<b>1. Gender</b>	Male	190	59.4
	Female	130	40.6
<b>2. Academic qualification</b>	BBA Hons./B.com	123	38.4
	MBA	169	52.8
	MSMS	28	8.8
<b>3. Division</b>	Sahiwal	107	33.4
	Lahore	75	23.4
	Multan	49	15.3
	Bahawalpur	16	5.0
	DG Khan	21	6.6
	Gujranwala	12	3.8
	Faisalabad	22	6.9
	Sargodha	18	5.6

Table 3 summarizes the results of path-analysis. It indicates that need for achievement has direct positive impact (H1: estimate=0.209, t=3.306, p<0.001) on entrepreneurial intentions supports H1. Risk taking does not have significant impact (H2: estimate=0.030, t=0.729, p>0.001) on entrepreneurial intentions does not support H2. Internal locus of control has direct positive impact (H3: estimate=0.578, t=11.642, p<0.001) on entrepreneurial intentions support H3. Openness to experience has direct positive impact (H4: estimate=0.140, t=2.608, p<0.001) on entrepreneurial intentions support H4. Extraversion does not have significant impact (H5: estimate=0.017, t=0.356, p>0.001) on entrepreneurial intentions does not support H5. It has been further analyzed that either attitude towards entrepreneurship plays a mediating role between personality traits and entrepreneurial intentions as investigated by Nishantha (2008) in the context of Sri Lanka. Path analysis did not support this argument in the context of business graduates of Pakistan and indicated that the direct effects were higher than the indirect effects which showed that attitude towards entrepreneurship has not a mediating impact between personality traits and entrepreneurial intentions among business students of Pakistan due to the social and economic conditions.

Table 3: Regression Weights

			Estimate	S.E.	C.R.	P	Label
Entrepreneurial intentions	<-----	Need for achievement	.209	.063	3.306	***	Accept
Entrepreneurial intentions	<-----	Risk taking	.030	.041	.729	.466	Reject
Entrepreneurial intentions	<-----	Internal locus of control	.578	.050	11.642	***	Accept
Entrepreneurial intentions	<-----	Openness to experience	.140	.054	2.608	.009	Accept
Entrepreneurial intentions	<-----	Extraversion	.017	.047	.356	.722	Reject

\*\*\*: P<0.001

Table 4 summarizes the model fit statistics. The values of Goodness of Fit index (GFI), Reliability Must Return (RMR), Normalized Fit Index (NFI), Informed Fit Index (IFI), Comparative Fit Index (CFI) and CMIN/df are all meeting the mentioned criteria so it is appropriate to say that the model is fit in this research context.

Table 4: Model Fit Statistics

Fit indices	Recommended value	Actual value
GFI	≥0.90	0.90
RMR	<0.10	0.025
NFI	≥0.90	0.949
IFI	≥0.90	0.950
CFI	≥0.90	0.950
CMIN/df	<3	2.875

Figure 2: SEM Results

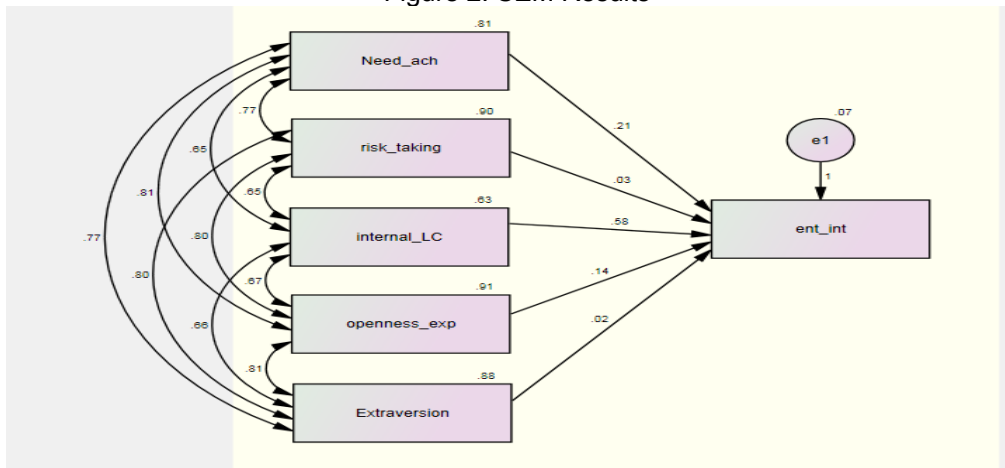

## 6. Conclusion

Entrepreneurship is gaining popularity all over the world and entrepreneurs are considered as “engines of growth”. This study aimed at investigating the impact of personality traits on entrepreneurial intentions among business students of Pakistan. Five personality traits need for achievement, risk taking, internal locus of control, openness to experience and extraversion were taken as independent variables and dependent variable was entrepreneurial intentions. It was supposed that need for achievement significantly affects entrepreneurial intentions among business students of Pakistan which has been accepted. It was also supposed that risk taking significantly affects entrepreneurial intentions among business students of Pakistan which has not been accepted. Further it was supposed that internal locus of control and openness to experience significantly affect entrepreneurial intentions among business students of Pakistan which have been accepted.

At the end it was supposed that extraversion significantly affects entrepreneurial intentions among business students of Pakistan which has not been accepted. Results of path analysis indicated that need for achievement, internal locus of control and openness to experience have significant impact on entrepreneurial intentions among business students of Pakistan. It has also been found that risk taking and extraversion does not have significant impact on entrepreneurial intentions among business students of Pakistan. So it is concluded that need for achievement, internal locus of control and openness to experience significantly affect entrepreneurial intentions among business students of Pakistan as depicted in table 5.

Table 5: Summary of Hypotheses Results

<b>H1 = Need for achievement significantly affects entrepreneurial intentions among business students of Pakistan</b>	Accepted
<b>H2 = Risk taking has significant impact of entrepreneurial intentions among business students of Pakistan</b>	Not Accepted
<b>H3 = Internal locus of control has significant impact on entrepreneurial intentions among business students of Pakistan</b>	Accepted
<b>H4 = Extraversion significantly affects entrepreneurial intentions among business students of Pakistan</b>	Not Accepted
<b>H5 = Openness to experience significantly affects entrepreneurial intentions among business students of Pakistan</b>	Accepted



## 7. Recommendation and limitations

Pakistan is a developing country and rate of unemployment is high so government of Pakistan can get benefit by properly identifying potential entrepreneurs and then providing them the means to start their own business. This study is beneficial in identifying the personality traits that can be helpful in recognizing entrepreneurial intentions among business students of Pakistan.

Like other studies, this study has also a limitation that it is only confined to business students in Pakistan. But there is also a possibility that students other than business education may have entrepreneurial intentions. So in future, research can be carried out to assess entrepreneurial intentions among non-business students and then comparing the entrepreneurial intentions of business and non-business students.

## References

- Ahmed, I., Nawaz, M. M., Ahmad, Z., Shaukat, M. Z., Usman, A., Rehman, W.-u., et al. (2010). Determinants of Students' Entrepreneurial Career Intentions: Evidence from Business Graduates. *European Journal of Social Sciences*, 15, 14-22.
- Ahmad, H. M. (2010). Personality Traits among Entrepreneurial and Professional CEOs in SMEs. *International Journal of Business and Management*, 5, 203-213.
- Ajzen, I. (1991), *The Theory of Planned Behavior*, *Organizational Behavior and Human Decision Processes*, 50, 176-211.
- Ajzen, I. & M.Fishbein (1980), *Understanding Attitudes and Predicting Social Behavior*, Eaglewood Cliffs, NJ. Prentice Hall
- Ali, A., Topping, K. J., Tariq, R. H., & Wakefield, P. (2011). Entrepreneurial Attitudes among Potential Entrepreneurs. *Pak. J. Commer. Soc. Sci*, 5 (1), 12-46.
- Aslam, T. M., Awan, A. S., & Khan, T. M. (2012). Entrepreneurial Intentions among University students of Punjab a Province of Pakistan. *International Journal of Humanities and Social Science*, 2, 114-120.
- Bagozzi, B.R. Bluedorn (1989), *The Relationship Between Corporate Entrepreneurship And Entrepreneurial Intention*, *Strategic Management Journal*, 20, 21-44
- Begley,, T., & D.B., b. (1987). Psychological Characteristics Associated with Performance in Entrepreneurial Firms and Small Business. *Journal of Business Venturing*, (2), 79-93.
- Beverland, M. and Lockshin, L (2001), Organizational life cycle in small New Zealand wineries, *Journal of Small Business Management*, 39(4), 354-362.
- Bird, B. (1988), Implementing Entrepreneurial Idea: The Case for Intention, *Academic of Management Review*, 13, 442-453
- Brockhaus, R.H. (1982). *The Psychology Of The Entrepreneur*. In *Encyclopedia of Entrepreneurship*, ed. C.A. Kent, D.L. Sexton, And K.H. Vesper. Englewood Cliffs, NJ: Prentice Hall.

- Brockhaus, R.H. and Horwitz, P.S. (1986). *The Psychology Of The Entrepreneur*. In *The Art And Science Of Entrepreneurship*, ed. D.L. Sexton And R.W. Smilor. Cambridge, MA: Ballinger.
- Begley, T., & D.B., b. (1987). Psychological Characteristics Associated with Performance in Entrepreneurial Firms and Small Business. *Journal of Business Venturing*, (2), 79-93.
- Caliendo, M., F.M., F., & A.S., K. (2009). Risk Attitudes of Nascent Entrepreneurs-New Evidence from an Experimentally-Validated Survey. *Small Business Economics*, 32(2), 153-167.
- Caliendo, M., F.M., F., & A.S., K. (2010). The Impact of Risk Attitudes on Entrepreneurial Survival. *Journal of Economic Behavior and Organization*, 76, 45-63.
- Chell, E., J. Harworth, and S. Brearley (1991). The search for entrepreneurial traits. In E. Chell, J. Harworth, and S. Brearley (Eds.), *The Entrepreneurial Personality: Concepts Cases and Categories*, Routledge Small Business Series, 29–53. London: Thomson.
- Chell, E. (2008). *The Entrepreneurial personality. A social construction* (2<sup>nd</sup> ed.). London: Routledge.
- Cramer, J., J. Hartog, N. Jonker, and C. Van Praag (2002). Low Risk Aversion Encourages the Choice for Entrepreneurship: An Empirical Test of a Truism. *Journal of Economic Behavior and Organization* 48, 29–36.
- Evans, D., & L.S., L. (1989). Some Empirical Aspects of Entrepreneurship. *American Economic Review*, 79(3), 519-535.
- Fisher, J. L. & Koch, J. V. (2008). *Born, not made. The entrepreneurial personality*. London: Praeger.
- Keong, L. C. (2008). *Entrepreneurial Intention: An empirical Study among Open University Malaysia Students*.
- Kickul, J. & Gundry, L.K. (2002). Prospecting for strategic advantage: the proactive entrepreneurial personality and small firm innovation. *Journal of Small Business Management*, 40, 85–97.
- Kihlstrom, R., & J., I. (1979). A General Equilibrium Theory of Firm Formation Based on Risk Aversion. *Journal of Political Economy*, 87, 719-748.
- Krueger, N. (2000), *Strategic Optimism: Antecedents of Perceived Probabilities of New Venture Success*, paper presented at The Academy of Management Meetings
- Littunen, H. (2000), *Entrepreneurship and the characteristics of the entrepreneurial personality*, *International Journal of Entrepreneurial Behavior & Research*, 6(6), pp. 295-309.
- Luca, M. R., & Cazan, A. M. (2011). *Involvement in Entrepreneurial Training & Personality*. Sciverse Science Direct, 1251-1256.
- McClelland, D. (1961). The Achievement Motive in Economic Growth. *American Economic Review*, 51, 179-189.
- McCrae, R., & John, O. (1992). An introduction to five-factor model and its applications. *Journal of Personality*, 60, 175-215.
- McCrae, R. (1987). Creativity, Divergent Thinking and Openness to Experience. *Journal of Personality and Social Psychology*, 52, 1258-1265.

- Mueller, S., & A.S., T. (2000). Culture and Entrepreneurial Potential: a Nine Country Study of Locus of Control and Innovativeness. *Journal of Business Venturing*, 16, 51-75.
- Nishantha, B. (2008). Influence of Personality Traits and Socio-demographic Background of Undergraduate Students on Motivation for Entrepreneurial Career: The Case of Sri Lanka. Doshisha Business School, Kyoto, Japan.
- Pandey, J. and Tewary, N.B. (1979). Locus of Control and Achievement Values of Entrepreneurs. *Journal of Occupational Psychology* 50: 107–111
- Perry, C. (1990). After Further Sightings Of The Heffalump. *Journal of Managerial Psychology* 5(2), 22–31.
- Rotter, J. (1966). Generalized Expectancies for Internal versus External Control of Reinforcement. *Psychological Monographs*, 80, 1-2.
- Sommer, L. and Haug, M. (2011), Intention as a Cognitive Antecedent to International Entrepreneurship: Understanding the Moderating Roles of Knowledge and Experience. *International Entrepreneurship Management Journal*, 7:111-142
- Souitaris, V., Zerbinati, S., Al-Laham, A. (2007). Do entrepreneurship programmes raise entrepreneurial intention of science and engineering students? The effect of learning, inspiration and resources. *Journal of Business Venturing*, 22, 566–591.
- Tanveer, M. A., Shafique, O., Akbar, S., & Rizvi, S. (2013). Intentions of Business Graduate and Undergraduate to Become Entrepreneur: A Study from Pakistan. *Journal of Basic and Applied Science*, 3(1), 718-725.
- Tett, R., J.R., S., & R.S., B. (2003). Broad and narrow measures on both sides of the personality-Job performance relationship. *Journal of Organizational Behavior*, 24, 335-356.
- Van Gelderen, M., Brand, M., van Praag, M., Bodewes, W., Poutsma, E. and van Gils, A. (2008), Explaining Entrepreneurial Intentions by Means of the Theory of Planned Behavior, *Career Development International*, 13(6): 538-559.
- Ward, T.B. (2005). Cognition, creativity, and entrepreneurship. *Journal of Business Venturing*, 19, 173–188.
- Wang, C.K. & Wong, P-K.(2004). Entrepreneurial interest of university students in Singapore. *Technovation*, 24 (2004) 163–172.
- Weitzel, U., Urbig, D., Desai, S., Sanders, M. & Acs, Z. (2010). The good, the bad, and the talented: Entrepreneurial talent and selfish behavior. *Journal of Economic Behavior & Organization*, 76, 64–81.
- Zhao, H., & S.E., S. (2006). the Big five Personality Dimensions and Entrepreneurial Status: A Meta-Analytical Review. *Journal of Applied Psychology*, 91(2), 259-271.
- Zhao, Z., Seibert, S.E. & Lumpkin, G.T. (2010). The relationship of personality to entrepreneurial intentions and performance: A meta-analytic review. *Journal of Management*, 36 (2), 381-404.