

Crimping Tool Wear and Tear Analysis

Dacian Ilca, Tiberiu Manescu*, Cristian Tufisi

Abstract. *This paper represents an investigation into spare parts longevity in the context of automotive production. By systematically examining the accuracy of the crimping process, our research unveils the potential for cost reduction by pushing the limits of the usage of crimping tooling, while maintaining production efficiency and quality. Preliminary findings reveal encouraging prospects, but underscore the necessity for further examinations, maintenance strategies, and the development of predictive models. Through the tests described in this paper and the obtained results, it has been concluded that the limits imposed by the procedure can be extended (thus reducing production interruptions and associated costs). Extending these limits cannot be determined by a universally applicable rule, therefore, additional analyses are necessary, analyses that will be the subject of further research.*

Keywords: *crimping process, spare parts lifetime, anvil, crimper, value engineering*

1. Introduction

The automotive industry faces relentless competition, evolving market demands, and stringent regulations, which drive the constant quest to cut production costs while upholding product quality and performance. This drive has given rise to the practice of value engineering, focusing on enhancing product efficiency while minimizing expenses [1], [2].

Within this context, a critical factor to consider is the longevity of spare parts used in specialized machinery. These often-overlooked components wield significant influence over cost-efficiency and productivity within automotive plants.

This paper aims to evaluate cost reduction possibilities in an electrical harness production plant by investigating the lifespan of spare parts employed in the crimping process. The crimping process is fundamental to electrical and electronic assembly, vital for creating reliable wire-to-connector connections in various industries, including automotive manufacturing.

©2023 Studia UBB Engineering. Published by Babeș-Bolyai University.



This work is licensed under a [Creative Commons Attribution-NonCommercial-NoDerivatives 4.0 International License](https://creativecommons.org/licenses/by-nc-nd/4.0/)

As the crimping tool's active parts endure wear and tear during regular use, they require replacement, impacting overall project costs. Standard maintenance protocols given by the crimping equipment suppliers typically recommend active part replacement when wear or damage is detected. Internally, work instructions dictate replacement after ½ years or at 200000 crimps (strokes). While efforts have been undertaken, there are presently no accurate methods for predicting the failure of spare parts [3], [4].

Our objective is to conduct tests to assess the validity of the 200000-stroke reference point for active part replacement and explore alternative methods for determining replacement, potentially extending the tooling's lifespan. We hypothesize that significant differences in spare parts wear exist among various crimping tools, which may necessitate a reconsideration of the current internal instructions.

This study aims to advance the current state of the field by introducing novel insights based on empirical analyses, thus opening up space for an integrated body of knowledge. By meticulously examining the accuracy of the crimping process in automotive production, our research not only extends the established boundaries but also suggest cost-effective methodologies to minimize production interruptions and expenses. This work's paramount contribution lies in its revelation of unexplored opportunities for enhancing longevity in spare parts, thereby fortifying the foundation for more efficient and economical manufacturing practices. The imperative necessity to optimize maintenance strategies and develop predictive models is underscored, highlighting the indispensable relevance of this research in steering the industry towards more robust and forward-thinking methodologies.

2. Methodology

The machine used for this study is a Schaefer eps 2000 (Fig. 1), used alternatively with two different crimping tools (applicators) from TE. The two critical tooling inserts within an applicator are the wire crimper and the anvil, commonly known as the active parts or spare parts (Fig.2).

The wear of the applicator active parts can be determined indirectly by examining the results of a crimp. In the context of this investigation, we have evaluated two distinct applicator types belonging to the same family (designated App_01 and App_02). We have used a cable with cross section 0.35mm² type FLRY-A and two terminals with the same material (CuNiSi).



Figure 1. Schaefer eps 2000 crimping machine

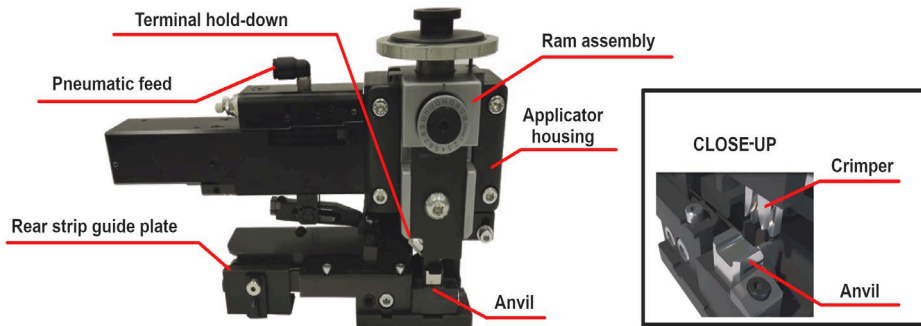

Figure 2. Crimp tooling: applicator parts and close-up of inserts

Our initial step involved recording the baseline value, as documented by the strokes-meter of each applicator. Given the extended duration of the testing, we introduced a protocol for measurement intervals, set at either every 5 working days or when the cumulative strokes reached 60000, depending on whichever milestone occurred first. At each of these designated points in time, we conducted assessments and measurements of the quality of the crimps, recording the results in a table. If the measured parameters were off scale, the experiment stopped and the final value on the meter was recorded. If no deviation was found after twenty iterations of testing, provided that the limit of 200000-strokes has been exceeded, the experiment was also stopped and the value on the meter recorded.

Evaluating the crimp quality is a method commonly used in the industry [5]-[7] and consists of specific steps and measurements, such as visual inspection: correct crimp (Fig. 3) or incorrect crimp (Fig. 4), cross section analysis (Fig. 5) and others.

In essence, a quality crimp ensures that the wire maintains the right shape and size without any excess material, deformities, or damage that might lead to connection failures [8].

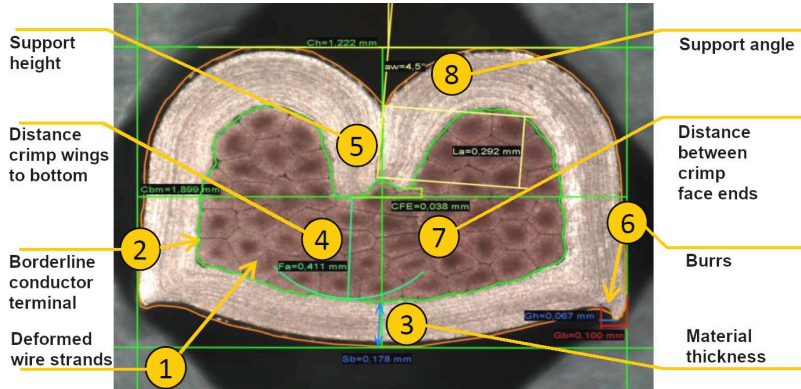

Figure 3. Microsection of the crimp, showing measurable parameters

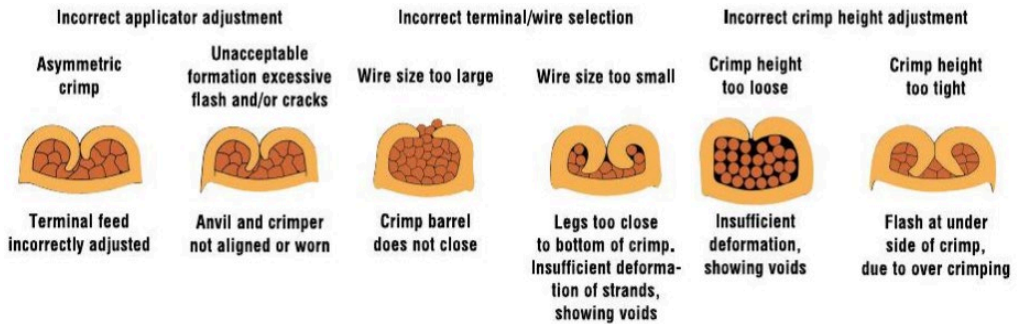

Figure 4. Incorrect crimp quality

A high-quality crimp should achieve the necessary area reduction without causing issues like flash (burr), over-crimping, under-crimping, or bending, respecting the nominal intervals for given value measurements (Fig. 5).

We applied the previously outlined methods to evaluate the crimp's quality and generated a dataset of values that were analyzed in Minitab software. The most significant parameters in our study are wire crimp height (CH), wire crimp width (CW), burr height (Gh) and burr width (Gb). Especially the latest two are indicative of spare parts wear or damage.

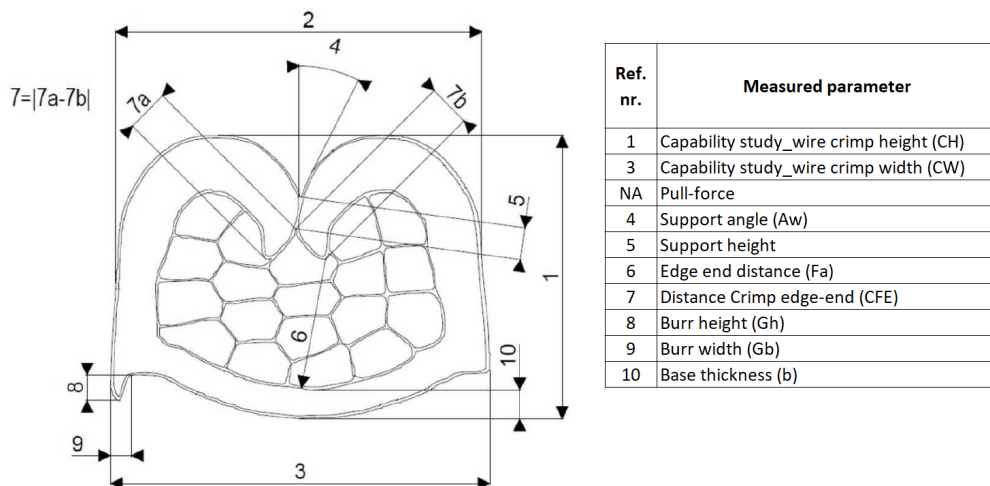

Figure 5. Crimp cross section measurable parameters

3. Data analysis and discussion

The dataset presented in Table 1 was collected through a series of test iterations focusing on the resulted crimps of two applicators, App_01 and App_02, with the aim of drawing insights and conclusions about their active parts wear and tear.

In line with our study's design, we concluded the experiment for App_01 after twenty recorded instances, even though the achieved crimps remained within the specified range (Fig. 6, 7). The initial meter reading of App_01 was 9308462, and the final reading reached 10163418, resulting in a cumulative total of 854956 strokes performed for quality crimps.

Table 1. App_01 Tests iterations and measured values of parameters

Nr. Crt.	Strokes number	Capability study wire crimp height CH 0.76 ± 0.03 mm	Capability study wire crimp width CW $1.40 + 0.15$ mm	Burr height Gh ≤ 0.20 mm	Burr width Gb ≤ 0.10 mm
1	9308462	0.7580	1.4070	0.0000	0.0000
2	9336012	0.7730	1.4210	0.0000	0.0000
3	9362092	0.7630	1.4640	0.0000	0.0000
4	9381825	0.7770	1.4540	0.0000	0.0000
5	9404857	0.7770	1.4510	0.0000	0.0000
6	9441572	0.7730	1.4450	0.0540	0.0000

Nr. Crt.	Strokes number	Capability study wire crimp height CH 0.76 ±0.03 mm	Capability study wire crimp width CW 1.40+0.15 mm	Burr height Gh ≤0.20 mm	Burr width Gb ≤0.10 mm
7	9479197	0.7810	1.4500	0.0000	0.0000
8	9519222	0.7550	1.4280	0.0400	0.0770
9	9544204	0.7670	1.4360	0.0500	0.0500
10	9569809	0.7730	1.4440	0.0000	0.0000
11	9630170	0.7740	1.4420	0.0000	0.0000
12	9690192	0.7560	1.4230	0.0260	0.0880
13	9750445	0.7780	1.4280	0.0000	0.0000
14	9777968	0.7650	1.4250	0.0000	0.0000
15	9822351	0.7730	1.4440	0.0000	0.0000
16	9882407	0.7640	1.4620	0.0000	0.0000
17	9931873	0.7600	1.4320	0.0330	0.0980
18	9956797	0.7790	1.4380	0.0000	0.0000
19	10051447	0.7840	1.4410	0.0800	0.0330
20	10163418	0.7860	1.4390	0.0210	0.0880

Remarkably, the cumulative number of strokes, which reached 854956, greatly exceeded the reference point of 200000 strokes as per the recommended spare parts exchange. This significant surplus in the number of strokes observed suggests a potential for extending the operational lifespan of the equipment.

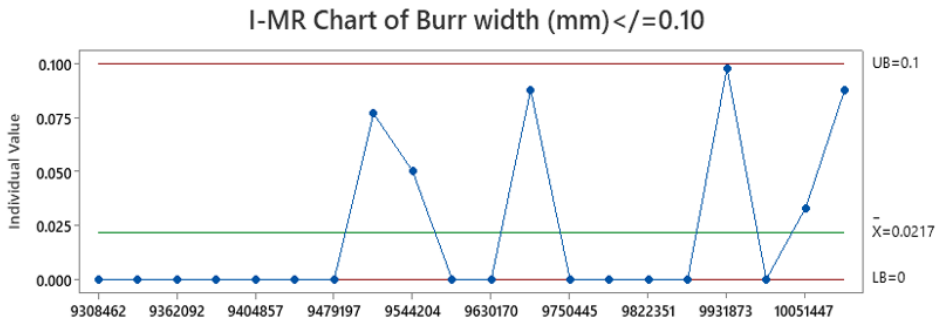

Figure 6. Control chart of the burr width for App_01

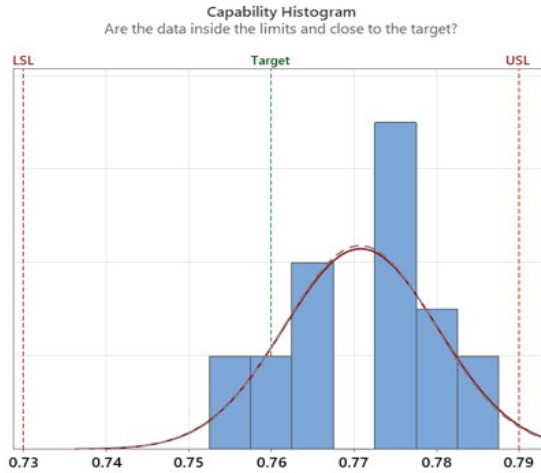

Figure 7. Histogram analysis of crimp height for App_01

Concerning App_02, the experiment was concluded after sixteen iterations (see Table 2) due to an observed defect.

Table 2. App_02 Tests iterations and measured values of parameters

Nr. Crt.	Strokes number	Capability study wire crimp height CH 0.78 ±0.02 mm	Capability study wire crimp width CW 1.07+0.11 mm	Burr height Gh ≤0.20 mm	Burr width Gb ≤0.10 mm
1	2299978	0.7800	1.0990	0.0000	0.0000
2	2312128	0.7970	1.1400	0.0000	0.0000
3	2325693	0.7750	1.1620	0.0000	0.0000
4	2336993	0.7650	1.1350	0.0000	0.0000
5	2358030	0.7730	1.1510	0.0000	0.0000
6	2380845	0.7850	1.1490	0.0000	0.0000
7	2397279	0.7970	1.1630	0.0000	0.0000
8	2406379	0.7880	1.1520	0.0340	0.0520
9	2429907	0.7970	1.1400	0.0000	0.0000
10	2447082	0.7730	1.1510	0.0000	0.0000
11	2471040	0.7650	1.1400	0.0000	0.0000
12	2485118	0.7970	1.1630	0.0000	0.0000
13	2491843	0.7710	1.1380	0.0210	0.0370
14	2505343	0.7840	1.1620	0.0000	0.0000
15	2522143	0.7980	1.1750	0.0000	0.0000
16	2553490	0.7860	1.1480	0.0640	0.1050

The deviation from the anticipated values was identified through the measurement of the burr width (Fig. 8). While the measurements for crimp height and width remained within acceptable ranges (Fig. 9), the observed deviation in burr width suggests a potential concern regarding the wear and tear of the anvil (as depicted in Fig. 10).

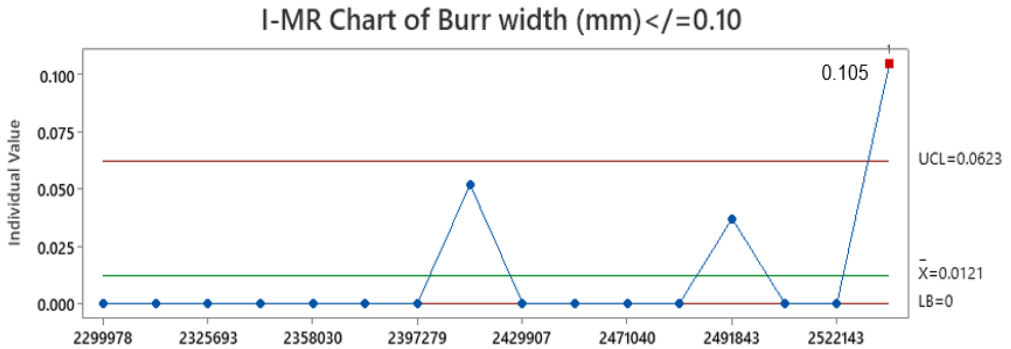

Figure 8. Control chart of the burr width for App_02

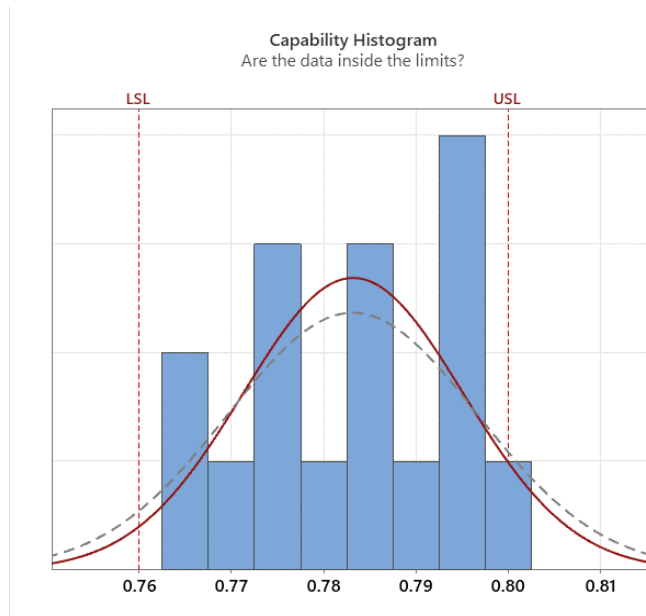

Figure 9. Histogram analysis of crimp height for App_02

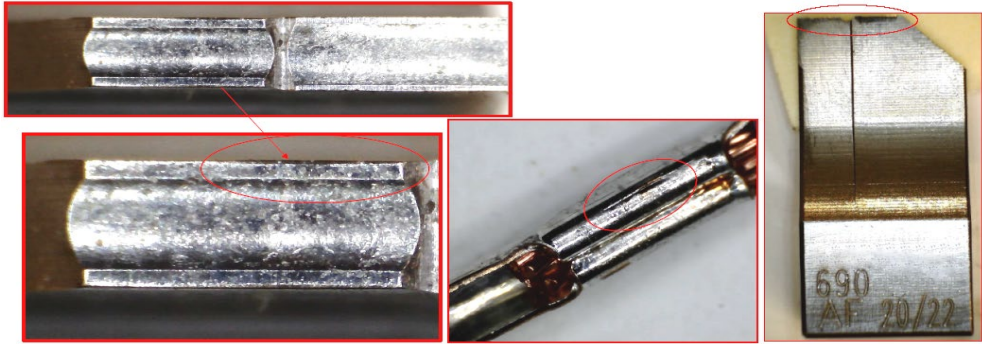

Figure 10. Damage on the anvil and the resulted crimp

The initial meter reading for App_02 stood at 2299978, while the final reading marked 2553490, reflecting a total of 253512 strokes. This cumulative stroke count, totaling 253512, surpassed the recommended spare parts exchange threshold of 200000 strokes, but not to the same extent as in case of App_01.

In light of our hypothesis that substantial variations in spare parts wear may exist among different crimping tools, the surplus of strokes, exceeding the recommended maintenance threshold, underscores the potential validity of our hypothesis. This outcome suggests that there may indeed be significant differences in wear patterns among these tools, necessitating a reevaluation of the existing internal maintenance instructions, while also stressing the need for further study in an attempt to be able to predict the lifespan of the spare parts.

4. Conclusions

Analyzing spare part longevity indicates potential for cost reduction in automotive production. While our initial findings are encouraging, it is evident that further testing is imperative to ascertain the complete lifecycle of these spare components.

Regular maintenance schedules and monitoring of spare part lifetimes can further enhance cost reduction efforts. A proactive approach in this regard is essential for enhancing production efficiency and cost-effectiveness.

Moreover, introducing a predictive model capable of simulating tests and extrapolating insights from empirical results represents a progressive avenue. Such a model could furnish valuable predictive tools, further refining cost-reduction strategies and potentially revolutionizing the management of spare parts in the automotive production process.

This study's significance lies in its immediate applicability within the automotive industry, where the delicate balance between cost reduction, quality maintenance, and operational efficiency is paramount. The potential implementation of these findings

could significantly impact production processes, leading to tangible reductions in costs and notable improvements in efficiency. However, the need for continued research is evident, beckoning further analyses and the development of predictive tools to refine maintenance strategies and deepen our understanding of spare parts management. Ultimately, this study not only identifies critical avenues for cost reduction but also lays the groundwork for the proactive, predictive methodologies that will shape the future of automotive production, establishing itself as a cornerstone in the ongoing evolution of the field.

References

- 1 Rachwan R., Abotaleb I., Elgazouli M., The Influence of Value Engineering and Sustainability Considerations on the Project Value, *Procedia Environmental Sciences*, 34, 2016, pp. 431-438, <https://doi.org/10.1016/j.proenv.2016.04.038>
- 2 Behncke F., Maisenbacher S., Maurer M., Extended Model for Integrated Value Engineering. *Procedia Computer Science*, 28, 2014, pp. 781-788, <https://doi.org/10.1016/j.procs.2014.03.093>
- 3 Mocellin K., Petitprez M., Experimental and Numerical Analysis of Electrical Contact Crimping to Predict Mechanical Strength, *Procedia Engineering*, 81, 2014, <https://doi.org/10.1016/j.proeng.2014.10.274>
- 4 Morgado L., Teixeira A., Sá, J. Pinto Ferreira L., Almeida F.D., Analysis and Development of a Failure Prediction Model for Electrical Terminals Used in the Automotive Industry, *Procedia Manufacturing*, 51, 2020, pp. 207-214, <https://doi.org/10.1016/j.promfg.2020.10.030>
- 5 Jongwuttanaruk K., Thavornwat C., Optimization of Mechanical Crimping in the Terminal Crimping Process Using a Response Surface Methodology, *Advances in Materials Science and Engineering*, Article ID 6508289, 2022, <https://doi.org/10.1155/2022/6508289>
- 6 Dragomir F., Manescu T., Gillich G.-R, Korca Z. Tufisi C., Influence of vibration and environmental factors on a crimped assembly resistivity, *Vibroengineering Procedia*, 51, 2023, pp. 173-178, <https://doi.org/10.21595/vp.2023.23681>
- 7 Castro T.A.M., Campilho R., Optimising a Specific Tool for Electrical Terminals Crimping Process, *Procedia Manufacturing*, 11, 2017, pp. 1438-1447, <https://doi.org/10.1016/j.promfg.2017.07.274>
- 8 SAE International, *Performance Specification for Cable-to-Terminal Electrical Crimps. SAE/USCAR-21*, 4th SAE International, U.S. and Canada, 2020. https://global.ihs.com/doc_detail.cfm?document_name=SAE%20USCAR%2D21&item_s_key=00407431.

Addresses:

- Ph.D. Stud. Eng. Dacian Ilca, Doctoral School of Engineering, Babeş-Bolyai University, Cluj-Napoca, Romania, Faculty of Engineering, Piața Traian Vuia, nr. 1-4, 320085, Reșița, Romania
florin.dragomir@ubbcluj.com
- Assoc. Prof. PhD. Habil. Eng. Tiberiu Manescu, Doctoral School of Engineering, Babeş-Bolyai University, Cluj-Napoca, Romania, Department of Automation, Industrial Engineering, Textiles and Transportation, Aurel Vlaicu University, Bd. Revoluției 77, 310032, Arad, Romania
manescu.tiberiu@gmail.com
(* *corresponding author*)
- Lect. Ph.D. Eng. Cristian Tufisi, Babeş-Bolyai University, Cluj-Napoca, Romania, Department of Engineering Science, Babeş-Bolyai University, Cluj-Napoca, Babeş-Bolyai University, Faculty of Engineering, Piața Traian Vuia, nr. 1-4, 320085, Reșița, Romania, tufisi.cristian@ubbcluj.ro