

DRAMATICA

STUDIA UNIVERSITATIS BABEȘ-BOLYAI

2/2015

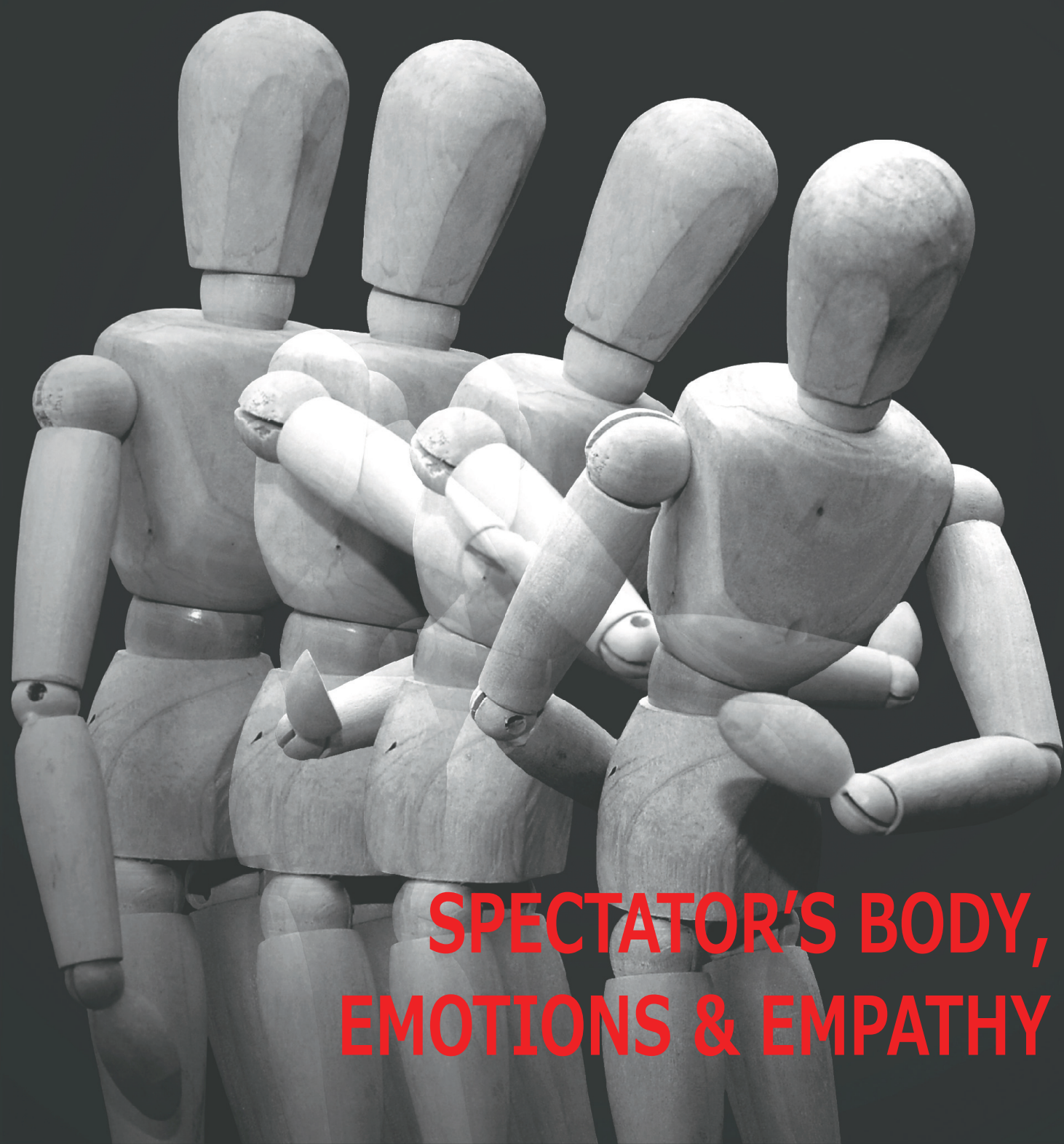

**SPECTATOR'S BODY,
EMOTIONS & EMPATHY**

**STUDIA
UNIVERSITATIS BABEȘ-BOLYAI
DRAMATICA**

**2/2015
October**

STUDIA UNIVERSITATIS BABEȘ-BOLYAI DRAMATICA

EDITOR-IN-CHIEF:

ȘTEFANA POP-CURȘEU, Babeș-Bolyai University, Cluj-Napoca

HONORIFIC BOARD:

GEORGE BANU, Université Paris 3-Sorbonne Nouvelle

ION VARTIC, Babeș-Bolyai University, Cluj-Napoca

MICHAEL PAGE, Calvin College

EDITORIAL BOARD:

LIVIU MALIȚA, Babeș-Bolyai University, Cluj-Napoca

ANCA MĂNIUȚIU, Babeș-Bolyai University, Cluj-Napoca

MIRUNA RUNCAN, Babeș-Bolyai University, Cluj-Napoca

LAURA PAVEL-TEUȚIȘAN, Babeș-Bolyai University, Cluj-Napoca

VISKY ANDRÁS, Babeș-Bolyai University, Cluj-Napoca

ANDREA TOMPA, Babeș-Bolyai University, Cluj-Napoca

IOAN POP-CURȘEU, Babeș-Bolyai University, Cluj-Napoca

DELIA ENYEDI, Babeș-Bolyai University, Cluj-Napoca

RALUCA SAS-MARINESCU, Babeș-Bolyai University, Cluj-Napoca

ANCA HAȚIEGAN, Babeș-Bolyai University, Cluj-Napoca

MIHAI PEDESTRU, Babeș-Bolyai University, Cluj-Napoca

INTERNATIONAL REFEREES:

DOMNICA RĂDULESCU, Washington and Lee University

PETER P. MÜLLER, University of Pécs

TOM SELLAR, Editor of *Theatre Journal*, Duke University Press, Yale University

JEAN-PIERRE SARRAZAC, Université Paris 3-Sorbonne Nouvelle

GILLES DECLERCQ, Université Paris 3-Sorbonne Nouvelle

PATRIZIA LOMBARDO, Geneva University

LAURA CARETTI, Università degli Studi di Siena

LIVIU DOSPINESCU, Université Laval, Québec

ISSUE EDITORS (2/2015):

MIRUNA RUNCAN and RALUCA SAS-MARINESCU, Babeș-Bolyai University, Cluj-Napoca

SECRETARY OF THE EDITORIAL BOARD:

IOAN POP-CURȘEU, Babeș-Bolyai University, Cluj-Napoca

EDITORIAL OFFICE: 4th Kogălniceanu Street, Cluj-Napoca, Romania,
Phone: +40 264 590066,

Web site: <http://studia.ubbcluj.ro/serii/dramatica>,

Contact: studia.dramatica@ubbcluj.ro

Cover design: Ileana Maier, *Tranzit teatral*, ilustrație, 2015

STUDIA UBB EDITORIAL OFFICE: B.P. Hasdeu no. 51, 400371 Cluj-Napoca, Romania,
Phone + 40 264 405352, office@studia.ubbcluj.ro

Thematic issue

Spectator's Body, Emotions & Empathy

CONTENT / SOMMAIRE

STUDIES AND ARTICLES

Miruna RUNCAN, Strategies for the Embodiment and Disembodiment of Spectatorship: <i>Don't Cry Baby</i> and <i>Hotel</i> by Eugen Jebeleanu.....	9
Debra LEVINE, Trisomic Stages: Theater Hora and Jerome Bel's Genetically Modified Theater	27
Laurelann PORTER, "Why Won't You Help Me ... Shave My Head?" Critical Autoethnography and Understanding Affective Response to an Act of Critical Vulnerability in Solo Performance.....	55
Iulia POPOVICI, Shame. Spectatorship Strategies in Historical Documentary Theatre.....	67
Alex BERCEANU, Cătălin CREȚU, Grigore BURLOIU, Dragoș CÂRNECI, Extension of Performativity by a BCI	77
Beatrice LEPADAT, Paradissolution – Ritual Communion within the Spectator- Performer Frame in <i>Parallel</i>	101
Ana PAIS, From Effect to Affect. Narratives of Passivity and Modes of Participation of the Contemporary Spectator	123
Claudia BLOUIN, Analyse sémiotique, identification kinesthésique, engagement du spectateur : quelle réception pour la danse-théâtre ? * <i>Semiotic Analysis, Kinaesthetic Identification, Spectator's Engagement: what Kind of Reception for the Dance-Theatre?</i>	151
Ramunė BALEVIČIŪTĖ, Towards Embodied Spectatorship	161
Alex CAHILL, The Theatrical Double Reflexivity Complex: How the Spectator Creates Metatheatre	173

Marina CRISTEA, Dramatic Space and Performer's Body, a Case Study	189
Andrei Tiberiu MAJERI, Mug Shot: Transraciality - Analysing the Race with Race in Art	199
Raluca BLAGA, The Battle for the Neuron's Wings	217

CREATION, INTERVIEWS, MISCELLANEA

MARIAN POPESCU, Spectators or Participants? A Major Creative Shift in Performing Arts or a Change of Status? (Remarks on a Process).....	233
MIHAI PEDESTRU, Who is the Audience? (And what is Theater?).....	239
ANDA CADARIU, Alternative Theatre in Poland and the Communist Dystopia	247
DIANA ALDEA, The Casting or the Two Headed Spectator – a Give and Take Process –.....	259
EUGEN WOHL, "Each of Us at Cricot-2 Had Their Own Personal Kantor". Interview with Teresa and Andrzej Welmiński, Renowned Actors of the Cricot-2 Theatre	273

PERFORMANCE, FILM AND BOOK REVIEWS

RALUCA SAS-MARINESCU, The End of Directing – A Foundation Study for Contemporary European Theatre Making	289
EUGEN WOHL, "MEMORY ... is Worth Thinking About!" – Transylvania in a Kantorian Key	293
IOANA PETCU, The Critic of Critique and Her Unrests.....	297
EUGEN WOHL, A Year of Celebration: The Centenary Birthday of Tadeusz Kantor (1915-1990)	301

STUDIES AND ARTICLES

Strategies for the Embodiment and Disembodiment of Spectatorship: Don't Cry Baby and Hotel by Eugen Jebeleanu

MIRUNA RUNCAN*

Abstract: This paper will emphasize a series of negotiation and renegotiation strategies for the corporeal-cognitive relationship between the actor and the spectator in contemporary experimental theatre. To this end, I have chosen two performances with totally different narrative and performative structures (a verbal one and a nonverbal one both staged by the same director, Eugen Jebeleanu and his team Compagnie 28: *Don't Cry Baby*, a play by Catinca Drăgănescu, based on the typologies/situations in Charles Perrault's *Little Red Riding Hood*, and *Hotel*, a free adaptation on F.X. Kroetz's *Wunschkonzert*). The paper mixes the descriptive analysis of Jebeleanu's performances with theoretical and applied perspectives from the fields of cognitive psychology and neurosciences, as well as of semiotics and pragmatics. The hypothesis I am trying to verify is that experimental shows performed in small spaces combine the corporeal-empathic and the cognitive challenges exerted on the spectator, sometimes turning the experience of the latter into a participatory game that involves an enhancement of one's proprioceptive internal sensations, a stronger perception of one's own body being alive and a participatory attendance.

Keywords: Spectatorship, Theatre, Performing Arts, Body Perception, Audience Response, Neurosciences

*"Things have an internal equivalent in me; they
arouse in me a carnal formula of their presence."
(Merlau-Ponty 1964, 164)*

The simplest conceptual description of the experience of theatrical action is perhaps the semiotic structure proposed by Erika Fischer-Lichte (1992, 401). The *Spectator* (S), by using the *Character* interface (X – a semiotic

* Professor PhD at Babeş-Bolyai University, Faculty of Theatre and Television, Cluj-Napoca, Romania;
e-mail: runcan.miruna@ubbcluj.ro

construct), engages in communication with the *Actor/Performer* (A – who “embodies” the fictional entity X). In an article published several years later (Fischer-Lichte 2008), the prominent theorist elaborates upon the simple equation S-X-A, by stressing that the semiotic perspective is limited only to the mechanisms of meaning production. This perspective is completed by various univocal or combined angles of investigation which, in the last three decades, have tried to circumscribe spectatorship from historical, sociological, phenomenological, pragmatic and especially neuro-psychological points of view.

It is indeed noteworthy that the last decades have generated huge changes in the field of reception studies, with the most spectacular ones produced by the exceptional headway made by neuro-sciences and mainly those dedicated to the brain functions, which were the immediate beneficiary of the advantages prompted by the new technologies. By means of applied research and by theoretical syntheses, neurologists themselves eagerly approached the spectator’s experiences, especially in the field of visual arts and of cinema, with outcomes that can be described as at least interesting (and often even revelatory) (see, for example, Freedberg D. and Gallese, C., 2007 and Raz, G. et alii, 2013). Researchers and analysts specialized in cinema or other arts showed a mutually increasing interest for using the new theories founded on the findings of neurosciences or even for taking part in interdisciplinary projects. From this point of view, the environment of theatrical research turned out to be, paradoxically, slow in joining in – unlike dance, where studies, colloquia and conferences on corporeality, perception and empathy in the performer-spectator pair are numerous. We must nonetheless admit that psychological-neurological experiences and applied studies that focused on the theatre spectator have been, until recently, almost inexistent: while complex equipment and computer programs were designed (see, for example, Raz, G. et alii 2013) for the measurement of the empathic processes experienced by the film spectator, the exploration of theatre spectatorship continues to be problematic. The space dedicated to the theatre audience is a shared one, while film can be watched in isolation, and the equipment will not bother other spectators. Furthermore, technological management seems more difficult in the live reception of a show. For this reason, the theatrical researchers’ and theorists’ references to this field of knowledge are still largely speculative.

We will try, however, to examine the empathically corporeal involvement processes experienced by the theatre spectator, using multi-tiered references that converge towards a (hopefully as clear as possible) picture of the interactions of sensations, emotions and meaning creation. For this analysis, we have chosen as

applicative models two markedly experimental independent performances of the same company - Compagnie 28, and of the same Romanian director - Eugen Jebeleanu.

*Two performances, two opposed spatial and narrative strategies.
A brief description*

Don't Cry Baby and *Hotel* were created successively, in 2013 and, respectively, in the second half of 2014; the former is based on a text written by Catinca Drăgănescu (herself a director, but also a playwright) and it starts from the situations and characters in Perrault's *Little Red Riding Hood*. Nevertheless, it has nothing to do with a children's play; instead, it is a tragic and biting satire, with a particularly dynamic writing, of (Proppian) archetypal situations occurring in Romanian society: At the head of a single-parent family is the mother, a high-ranking civil servant who runs all sorts of shady affairs and neglects her child. Little Red Riding Hood / Sonia is a disoriented teenager who is constantly in search of money and who tries to get her mother's attention by opposing her demonstratively and even coming to loathe her. The Wolf is a small time crook who sells to the mother a stolen telephone which he later, by coincidence, tries to buy again from Sonia; this is the start of a series of events that will eventually lead to the tragic ending. The Hunter is a wretched unemployed man with a sick wife. He works several unofficial jobs, among which that of driver and handyman for the mother. Grandmother lives in another city; she is paralyzed and senile, which is why the Hunter is required to drive Riding Hood/Sonia, at weekends, to visit the old lady. At the end of such a visit, the Hunter catches the Wolf in the act of robbing the house and abusing the old woman and Sonia: in the struggle, the Wolf is accidentally killed. The media jump on the juicy drama, Sonia is in shock and does not want to recount what actually happened, which leads to the Hunter being convicted for murder. Sonia is forced by her mother to go study abroad, while the scandal expires.

Aside from these characters, the play has a presenter/commentator, whose role is both lyrical and structuring in relation to the mechanisms of the theatrical convention: he/she (Nicoleta Lefter) introduces him/herself with the director's name, announces the brief scenes and the characters who will engage one another, comments expressively on the characters' and, potentially, the spectators' frame of mind; he/she refers to current social and political circumstances, asks questions or suggests topics the audience could contemplate.

The playing field/stage space is narrow, a path of several meters in-between the two audience rows. The actors move in this field on wheeled office chairs; all of them wear black (with the exception of the commentator who stands at one of the ends of the playing alley). The performers are two women and three men and their clothes are as simple as they are mixed: one of the women wears trousers, one of the men a plunging blouse and high heels. The actors will exchange roles several times, from one scene to another, without taking into account the character's gender or they will confess, at a certain point, their own civil identities, in comments on the colleagues' acting or on the topics and secondary topics of the performance.



Fig. 1: *Don't Cry Baby*, © Adi Bulboaca

Hotel is a fully distinct nonverbal performance, a free adaptation of *Wunschkonzert* (*Concert on demand*) by F.X. Kroetz. In a small space, surrounded on three sides by spectators, a hotel room is almost naturalistically reconstructed. In the beginning, a young woman lives there (Camelia Pintilie); she is eagerly waiting for someone, but this person (lover?) is not showing up. At a point, an older woman (Emilia Dobrin) appears in the hotel room; she is someone

devoted to their own routines and excessively calm, who will try on several times the same new dress or will make her bed, prepare her medicines, glass of water, while trying in vain to fall asleep. The two women do not interact and do not see each other, their activities are simultaneous and parallel, which suggests different temporalities and manifestations that are overlapping in the same space. After a while, a third character enters the room: a transvestite (Ștefan Huluba), who seems to soothe his extenuation and depression in mechanical, unhurried, almost hallucinatory actions. The three characters materialize their existence, invisible to one another, through minor and natural actions that generate increasing tension. In the end, the young girl leaves unhappy, while the remaining characters discretely suggest, each, a planned/possible suicide.



Fig. 2: *Hotel*, © Ruth Borgfjord

Engaging the character: embodiment and disembodiment of the spectator

In the already classic book *Engaging Characters. Fiction, Emotion and the Cinema* (1995) Murray Smith proposes, in manifest contradiction with previous theories on the processes of the spectator's identification with the

character¹, a formula for triggering cognition, emotion and imagination, structured on three tiers. The first step is *Recognition*, "... (the) spectator's construction of the character: the perception of a set of textual elements, in film typically cohering around the image of a body, as an individuated and continuous human agent"; the second step is *Alignment*, stemming from recognition, but meaning the spectator's harmonization with the character's credible structural coherence in the imaginary context. According to Smith, *Alignment* is obtained by, "...two interlocking functions, spatio-temporal attachment and subjective access..." (Smith, 1995, 83). Finally, the third tier is that of the investment of trust, *Allegiance*, which "pertains to the moral evaluation of characters by the spectator" (Smith, 84). This means the exploration and assessment of the character's actions, based on the moral coordinates and the level of knowledge displayed by the character in relation to one or another dramatic situation. I believe that, if we look closely, this three-tier organization of engagement could equally be applied to theatre and not only to cinema.

In *Hotel*, the spectator's processes of engaging the characters are linear, on the one hand – the same actor plays one character, which means the established "*one actor: one character*" convention is maintained, and the stage actions are not interrupted by breaks or changes of setting. On the other hand, the absence of speech and the strictly chronologic observation of these actions unfolding, most of the times, in complete silence, lay a markedly high claim on the spectator's imaginative possibilities (in the narrative plane, the spectator is forced "to fill the blanks", between recognition and alignment). The spectator will have the freedom of (but will also be responsible for) inventing, step by step, an outer stage context and a virtual individual destiny that precedes the actions seen in the "present time" of the representation, which should allow him to reach a certain degree of *allegiance*. However, the apparently naturalistic convention gradually requires him to renegotiate the "realism" premises of this third tier, as long as the three characters do not engage with one another. The spectator's voyeurism is also overinvested and compelled to produce an additional convention, i.e. space oneness in a temporal discontinuity.

However, the performance does not prompt only this twofold semiological challenge: to a considerably more prominent extent, we perceive the occurrence of an open shift from the area of observation focused on the production of

¹ In the initial part of the volume, the author carefully contradicts the theses proposed by Noël Carroll, 1988.

meaning by interpreting the observed actions, to the area of empathic, psycho-physical reaction, between the spectator and the actor; which means that, here, the character operates, to a great extent, as a mobile, unstable interface. When taking part, by means of perception and imagination, in the movements and actions of the characters embodied by the actors – several meters away – the spectator has an involuntary reaction which is both deeply subjective and intensely physicalized.

Neurologic theories on embodied simulation – ES – (Rizzolatti, G., Fogassi, L., & Gallese, V., 2001; Schwoebel J, Coslett HB; Freedberg, David; Gallese, Vittorio, 2007 etc.) help us understand from a more profound perspective that the reception of a (theatre, film) performance is not only an encoded game of searching for the global meaning layers of the artistic work, but also, to an amazing extent, an empathic induction that has both a physical and an imaginary response.

Our capacity to pre-rationally make sense of the actions, emotions and sensations of others depends on embodied simulation, a functional mechanism through which the actions, emotions or sensations we see activate our own internal representations of the body states that are associated with these social stimuli, as if we were engaged in a similar action or experiencing a similar emotion or sensation. Activation of the same brain region during first- and third-person experience of actions, emotions and sensations suggests that, as well as explicit cognitive evaluation of social stimuli, there is probably a phylogenetically older mechanism that enables direct experiential understanding of objects and the inner world of others. (Freedberg and Gallese, 2007, 198)

In this light it appears that the so-called “passivity of the spectator”, a long-term unchallenged assumption of reception theories (as well as of late modernity artists) in performing arts, is devoid of any ground. Spectatorship can no longer be seen as a passive activity, but as a complex process of fully systemic activation of the mind and body together. It would therefore be appropriate to abandon for good the demeaning postulate of “passivity”, as long as perception itself is conceived of as “simulated action”. (Berthoz 2000, 10)

Action observation causes in the observer the automatic activation of the same neural mechanism triggered by action execution. The novelty of these findings is the fact that, for the first time, a neural mechanism allowing a direct mapping between the visual description of a motor act and its execution has been identified. This mapping system provides a parsimonious solution to the problem of translating the results of the visual analysis of an observed movement – in principle, devoid of meaning for the observer – into something that the observer is able to understand. (Freedberg, D.; Gallese, V., 2007, 520-21)

In the relationship between the spectator and the actors in *Hotel*, the absence of any communication among the latter and the constant suggestion that the characters are not aware of each other's presence strongly enhance the embodied simulation reactions. Successively, the spectator (also "unobserved" by the actors) receives by transfer each character's anxious corporeality and he/she becomes hyper-sensitive to interception². The spectator drinks the actress's tea, feels the touch of the make-up brush and the thickness of cream spreading on the cheek, smells the rose or feels the silk slide on the skin when the performer dresses in it. The feeling of "observable", immediate solitude, multiplied by three simultaneously imagined destinies, increases the personalized effect of materiality (and of guilty frustration) of the contact between the one who sees and the one who lets themselves be seen. This *physical analogue* which is the character (Smith, 26) becomes almost permeable for the spectator, in a both enticing and somewhat obscene way:

We see that we are acted upon and we know that as part of this dialogical contract of interanimation we too are doing the acting. In seeing acting we are also acting seeing. (Fenemore, 2007, 2).

As a result such a performing discourse strategy, I, the spectator, become, almost unknowingly, not only cognitively empathic toward the other's desperate loneliness, but also sensitive, by imaginative and mimetic transfer, to my own secluded corporeality. We do, however, note that the extent of *embodied simulation* (ES), like, in general, the empathic predispositions, are considerably different from one spectator to another and they are generally controlled/compensated by the neurologic systems accounted for in *Theory of Mind* (ToM)³.

² "Interception works along with proprioception and exteroception to provide the brain with a complete information about the rest of the body, and its cortical representation in the insula is thought to be part of a system for emotional expression and self-consciousness" (Berlucchi and Aglioti, 2009, 31)

³ For a comprehensive applied exemplification with a potential for theory development, see Gal, Raz et alii (2013, 35): "Particularly – and to our knowledge, unprecedentedly – we found the dynamic patterns of connectivity of these circuits to be associated with empathy experienced under realistic situations. Furthermore, our data indicate a growing interaction of these circuits with a set of subcortical limbic structures during the intensification of empathic engagement. However, these findings also evince a context-dependent dissociation between empathy-related brain processes, suggesting that emotional sharing is based on the interplay between ES- or ToM-related processes, which may alternatively dominate empathic engagement."



Fig. 3: Hotel, © Ruth Borgfjord

While, with *Hotel*, the construction of significance is overtly and deliberately subject to the spectator's reactions of emotional transfer and unconscious embodiment, with *Don't Cry Baby* the aesthetic and communicational strategy comes from the opposite end. First, since the spoken text is extremely important here, its construction (with brief scenes, each of them illustrating only one situation, usually with two characters) is meant to organize the "cognitive act" witnessed by the spectator. The latter is challenged to use interactively the recognition and alignment processes, like pieces of a puzzle, while trusting in their own ready-shaped judgment (allegiance) of the fairy tale character's archetypal position. As we were saying, the titles of each scene and the characters' identity are (in a markedly Brechtian procedure) announced by the commentator. Thus, the character's identity is "stated" and wrapped into the archetype, and the purpose of this challenge is for the spectator to travel the reverse path: from the cultural meme to the social and psychological "embodiment" that relates to the local day-to-day life.

If the text and the performance had had only this target, they wouldn't have been unusual at all. The rewriting of myths and fairy tale situations from a contemporary perspective is a constant exercise of European modernity in prose,

theatre and in filmmaking. But in *Don't Cry Baby*, Eugen Jebeleanu proposes an additional challenge to engaging the character. He breaks the continuity of the actor-character relationship, going against the classic rule of "one character: one actor". Any of the actors can become, in turn, the Grandmother or the Wolf, the Hunter or the Mother, irrespective of their gender.

Of course, given the 'one performer: one character' convention has been almost universally upheld throughout the history of cinema, it is, for us, second nature: but it is *second* nature, a convention. The convention is not, however, arbitrary, it is motivated by both the function it performs and the material conditions of its making. If the goal is the presentation of concrete persons, then the 'one performer: one character' convention suits the task well, since it fits with the assumption that concrete individuals are possessed of one body and only one body. But other conventions can perform this function, and certain conditions will lead to the adoption of a different convention, even where the same representational goals prevails. Small theatre companies, for example, often use a 'single performer: multiple character' convention, in which each performer undertakes a number of roles... (Smith, 28-29)

Certainly, in the performance we are considering, the small number of actors and the strategy of role exchange from one scene to the next are not dictated by "economic" reasons, but by reasons that are equally aesthetic and ethic. Following the mental negotiation of the trans-realistic convention (one character: multiple bodies), the spectator will focus, this time, on each actor's performative ability to reconstruct without causing discontinuities in logic, in the narrative or in relational verisimilitude the character left behind by another actor. This "physical analogue", this interface that is the character will also obtain each time a new image-dimension that will not dissolve, but, quite the opposite, will add to the archetype's "material" (social, pragmatic, experientially "recognizable") weight. Or, to quote Murray Smith again;

These texts do not attempt simply to re-create the conventions of medieval allegory, but rather set up a field of tension between the very different functions of the individual human figure in realist fiction, on one hand, and allegory, on the other. Form, in these instances, 'roughens' our perception of function. (29)

Here, the process of enhancing the plasticity of our capacity of perception overlaps, I believe, with a rewriting of the relationship of induction and transfer from the actor to the spectator. This time, the spectator is constantly invited to participate in the hide-and-seek game with the character, that becomes more than an interface meant for the empathic transfer: the character's successive re-embodiment displaces the spectator's attention from the ES controlled empathic zone to the one controlled by ToM: in other words, from the natural-

unconscious tendency to “experience” the character to the observational control of one's own opinions, beliefs and cognitive decisions regarding the “solution” given to the plot by its performance. We could say we are dealing with an extreme application of Brechtian theses on distancing: the spectator goes, together with the actor, towards the reconstruction of the contact “with the character”, without falling deeply, cathartically, “in the character”⁴.

Caught in the web of theatrical action, the spectator empathizes with the ethic-aesthetic construction model, without denying his own interoceptive reaction, but merely placing it in parentheses, disembodying it. He/she does not necessarily reject a sympathetic relationship with the actor, but his/her reception focuses on the interpretative challenge of the incredibly dynamic two-layer game proposed to him. Thus, the performance introduces a strategy of fractal-like representation of the artefact that is the character; through this strategy (which alludes to the one in a Role Playing Game), we go back,



Fig. 4: *Don't Cry Baby*, © Claudiu Popescu

⁴ To this end, see the final hypotheses of the experience by Gal, Raz et alii (37), based on the measurement and comparison of brain reactions to viewing two films with tragic topics, *Stepmom* and *Sophie's Choice*.

on the one hand, to the allegoric generalization, and, on the other hand, to the perception of the unstable survival values of our everyday life. Anyone can be the executioner, even the very victim, irrespective of gender or of the prefabricated image. Paradoxically, it is precisely by the successive role reallocations that the character packs a strong abstract-symbolic aura, and the actor-spectator relationship reaches a level of reciprocity, of honest and most unusual communication.

This is also why the authors (Drăgănescu/Jebeleanu) needed an apparently neutral character, the commentator. Although her role is unique (in line with the established convention “one character: one performer”), her functions are multiple, in reverse agreement with the entire structure of the play. From the very beginning, the commentator introduces the rule of the game of symbolic “indifference” to gender: she is played by an actress who introduces herself as Eugen Jebeleanu, the director. Successively, she is charged with introducing the scene titles and characters (with an effect of maximum “bookish” distancing, that builds the theatrical discourse in plain sight); she also voices a series of personal, often nearly poetic thoughts on the other characters, on political events or on how they are approached in the media, on statistics and their significance, on the heroes’ later fate etc. The strategies of “in gaming” disembodiment and distancing proposed by the fictional/dramatic context of the plot are thus countered and compensated by this declaredly subjective voice, which produces an invisible bridge “in progress” between the author (in the end, also an artefact) and the spectator. The spectator’s self-reflexive “power” position is, therefore, assimilated to the auctorial one: the author’s assumed voice has become a possible embodiment of the spectator’s (inner) voice, in the shared space of the theatrical representation.

Space, hyper-proxemics and body movement

Most of the time, we give only a fleeting thought to the fact that spectatorship is also, to a great extent, an experience of our body in space. In performance reviews, the spectator’s immersion in the fictional space of the representation is not the object of analysis; the critic may at most be interested in the stage design and the costumes. With the exception of the cases where, as spectators, we are required to physically cross a number of spaces of the performing action, traditionally we have only one fixed angle from where we can configure, by observation, the “place” or “places” of the dramatic context. Moreover, European theatre has kept a net separation between the

dynamic space of the representation and the audience's neutral/ static one, by favoring, until recently, the distribution of the performers and actors, as compact groups, on one side and on the other of the "stage mirror". Of course, the distinction between "space" and "place" relates to Certeau's thesis (1984, 117) according to which *space* is a vector field created by the movement of bodies/objects, while the *place* is a field of the view, which results from the coherent coexistence of some objects/bodies.

From such an angle, together with what we already know (experimentally or only theoretically) about the neuro-psychological mechanisms of perception and orientation of one's own body in space, spectatorship is neither univocal, nor passive. In fact, the relationship between the spectator and the space of the performative actions is both a specular one – of semiotic and empathic knowledge of the "place" – and a vector one – of placing an imaginary movement of one's own body in the "space" thus configured. Even if his studies relate to film only, I believe Antunes's observations on vestibular perception are as convincing as they are applicable to theatrical reception:

I infer that remaining still in a chair does not diminish our capacity to engage with a film in an embodied, and particularly vestibular, fashion. In a nutshell, the vestibular sense can help us understand the generation of meaning derived from the embodied relationship between the spectator and the film, between the mind and body, and between the self and the outside world. (Antunes, 2012, 526)

The only aspect shared by the two performances we are examining here is that they take place in small spaces rather than in traditional theatre halls; thus, the distance between the spectators and the actors is reasonably small (with *Don't Cry Baby* no more than 1.5m between the first row of spectators and the performers, on both sides of the acting space; with *Hotel*, a maximum of 2 meters on three sides between the first row of spectators and the configured limits of the room). We first need to consider the profound changes in reception prompted by this hyper-proximity between the actor and spectator:

To compensate for a reduced physical impression, the actor in a large space performs in larger-than-life manner.(...) Thus when a performance occurs in a small theatre, especially one where the ludic space is not architecturally divided from the watching space, the proximity of A's body is the dominant physical impression made upon S. While distant views of a proscenium performance normally affect only the eyes and ears, keeping the danger of A's body at bay, the corporeal contiguity of small space performance can affect the range of senses. The results are not necessarily pleasant –especially when touch and smell are involved – but they provoke the audience to recognize that the actor is not merely a walking shadow. (...) This is one of the chief reasons why a strictly

semiotic view of the spectator's condition is insufficient, since the intimate and adjacent presence of the actor conveys so clearly the paradox of the theatrical double: the actor's otherness is both aesthetic object and human incidence, both signifier and corpus. (Kennedy, 2009, 138)

Without lingering strictly in the semiotic field, we cannot but note, however, that hyper-proximity has immediate effects on both of the participants to the theatrical communication: the actor is required to control more rigorously his verbal discourse, voice amplitude and corporal/mimic discourse, because any detail of his acting and presence is visible and significant, the spectator's eye operating like a camera lens that frames either in wide angles or in close-up. The spectator is also subject to greater corporal and mimic constraints, whether being aware of it or not. While in a 500-seat room the spectator could fidget, or nibble (discreetly, we hope!) on a piece of candy or wave a hand-held fan – let alone receive and send text messages –, in a small space any such gesture would disturb the stage action and would divert the other spectators' attention. Hyper-proximity has an effect that triggers in the spectator, to a consistent extent, the suspicion that he/she also is (or could also be) the object of another's gaze, be it that of the actor or of the other spectators. This doubly oriented tenseness does not only have semiotic-aesthetic effects, it also has neuro-psychological, corporeal effects on the general proprioceptive processes in the spectator's mind.

In *Hotel*, hyper-proximity to the naturalistic design of the room, as well as the natural, silent movement of the actors markedly suggest that the characters do not expose themselves, but they are caught at the deepest level of intimacy and mechanical routines. Focused, tensed attention acts almost directly, analogically, by embodied simulation (ES) mechanisms on the spectator's body and on his vestibular system, which makes him/her move, at an imaginary level, both "with the character" and "in the character", to paraphrase Gal et alii.

Embodiment theories of perception hold that this action-directed mode of visual perception is actually the dominant orientation we have to the world: "perception is simulated action" (Berthoz 2000, 10) (...) Simulated actions involve motor images, which are schemata of motor activity stored in memory. There are motor images for everything from the formation of one's hand needed for grasping a teacup to the lowering of one's legs into a cold swimming pool. Carried along with the motor processes in the how mode of visual perception are associated sensory qualities – the smooth texture of the teacup handle you grasp and the frigidity of the water into which you plunge your reluctant legs. (Esrock, 2010, 226)

On the other hand, the linear continuity of stage action and the rhythms of its unfolding (the characters are not hurried, their small gestures – undressing, dressing, putting on make-up, reading e-mails or a book, obsessive fitting of the new dress, combing, preparing and using necessary objects etc.) prompt in the spectator unconscious tactile urges, which we could validly enter in the category of the haptic dimension of images, as theorized – again in relation to cinema – by Laura Matks (2002):

Haptic images invite the viewer to dissolve his or her subjectivity in the close and bodily contact with the image. The oscillation between the two creates an erotic relationship, a shifting between distance and closeness. But haptic images have a particular erotic quality, one involving giving up visual control. The viewer is called to fill in the gaps in the image, engage with the traces the image leaves. (Marks, 13)

Thus, by merging the motoric simulation that configures the space (turning it into a “place” that includes the viewer) with the haptic dimension of the images, the spectator is overwhelmingly “absorbed” in the characters whose prehistory and future he envisages simultaneously. The “place” becomes an epitome of his/her own (fleeting) occupancy not only of an ordinary hotel room, but of his/her own body: that which belongs to us, but it is also foreign to us, it is ours and, analogically, it is also the Other’s. From this point of view, the spectator’s experience in *Hotel* seems to prove, overall, the working hypothesis of Ellen Esrock’s article:

I suggest that the most obvious quality we associate with our inner body is the feeling of being alive, for interoceptive awareness of the body is an awareness of that which is animate, living. Integral to being alive is the capacity for self-initiated movement. There is also a self-referential quality to interoception. When we project the inner body and a sense of ourselves that goes along with this, we might feel ourselves located, in some fundamental way, in the artwork or reconstituted as the artwork. (229)

In *Don’t Cry Baby*, the spectator’s insertion in the space of the stage action is completely different from the one in *Hotel*; it is as (at first glance) simple as it is demanding and sophisticated. Here, the stage space is strictly conceptual (it looks like a very narrow alley between the two rows of spectators who can see one another) and there is no figurative element to visually suggest the “place” of the actions. Thus, the succession of scene-related “places” will be configured in full by the spectator, in an imaginary way, starting from the minimal information provided by the commentator

in the intertitles. The spectator's attention is focused, as we have shown in the previous chapter, on the text-contained and text-operation dramatic situations and on the actors' abilities to jump from one character to the next, as well as from the character to the exhibition of their own civil identity⁵.

To make it possible for this type of involvement in the game of construction of situations and significations to occur, the team chose the ingenious solution of "sitting movement". The spectator rows are ranged in a mirror layout, and not only is the distance between the spectators and the actors unusually small – but, just like the spectators, the actors are sitting on chairs. They will only stand up in the rare cases where the conflict requires them to change their position or elicits violent attitudes. From one scene to another, they will cross the alley and reposition themselves only helped by the wheeled office chairs. Moreover, when two actors are performing, the other ones are still and look at them, just like the spectators, displaying relaxed, off-stage attitudes, and even sometimes commenting gesturally the acting of those who are involved directly.

This double constraint of the actor, who is thus coerced to build the successive character identities extremely carefully, with a very economic inventory of bodily-gestural means, reflects directly also on the spectator's system of motor/vestibular stimulation. On the one hand, to be able to perceive/observe correctly, the spectator will have to change successively the actual position of his head and even of his body, moving involuntarily according to the positions of the actors who, at this or that moment, are in focus, closer or farther away from him, at the right side, at the center or at the left side. On the other hand, the minimization of the space that separates the spectators' area and the performing area produces, within the spectator, interoceptive and proprioceptive reactions of embodied simulation, where the movement and spatial (vestibular) perceptions are transferred directly from the actor. Thus, the character has become some sort of transparent window where the spectator's physical analogue is the actor himself, as such. Metaphorically, the moving chairs in *Don't Cry Baby* do more than provide the spectator with an RPG space with multiple (disembodied/re-embodied) avatars; they also offer the experience of "occupying" the stage and of performing in his/her imaginary, at the same time with the actors.

⁵ ".....the actor on a bare stage, especially when partly surrounded by spectators and untrammelled by decorations, is chiefly perceived as a body speaking text. In a small theatre the spoken word becomes as intimate as environment, insidious, urgent and intrusive". (Kennedy, 139)

To sum up, we could state that the performances we chose to analyze bring forward, effectively, by their purposefully different aesthetic strategies, some of the deepest motivations that bring the spectator inside the space of theatrical communication: the pleasure of the mental-cognitive game and the pleasure of experiencing alterity, physically and emotionally. The latter, as we hopefully have demonstrated, is equivalent, to a great extent, with taking possession of one's own body, even at an unconscious level. Therefore, the aesthetic experience is proven to be a fundamentally existential one: when the performance is vibrant and incisive, it does not only make us "witnesses" to the story in progress in front of us, but it also increases the plasticity of our self-perception. It challenges us to perform it, because we own it.

References

- ANTUNES, Luis Rocha, 2012, "The Vestibular in Film: Orientation and Balance in Gus Van Sant's Cinema of Walking," *Essays in Philosophy*: Vol. 13: Iss. 2
- BERTHOZ, Alain, 2000, *The Brain's Sense of Movement*, translated by Giselle Weis, Cambridge, MA, Harvard University Press
- BERLUCCHI, Giovanni; Aglioti, Salvatore M., 2009, „The body in the brain revisited“, *Expanded Brain Research*, Springer-Verlag, p. 25-35
- CARROLL, Noël, 1988, *Mystifying Movies: Fads and Fallacies in Contemporary Film Theory*, New York, Columbia University Press
- De CERTEAU, M., 1984, *The Practice of Everyday Life*, Berkeley, Los Angeles and London, University of California Press
- ESROCK, Ellen J., 2010, *Embodying Art: The Spectator and the Inner Body*, *Poetics Today*, 31:2
- FENEMORE, Anna, 2007, „On Objects' The Pleasure of Objectification: A Spectator's Guide“, *Performance Research* Vol. 12, No. 4
- FISHER-LICHTE, Erika, 1992. *The Semiotics of Theatre*, Bloomington, Indiana University Press
- FISHER-LICHTE, Erika, 2008. "Sense and Sensation: Exploring the Interplay between the Semiotic and Performative Dimensions of Theatre", *Journal of Dramatic Theory and Criticism*, Vol XXII, no 2
- FREEDBERG, David; Gallese, Vittorio, 2007, „Motion, emotion and empathy in esthetic experience“, *TRENDS in Cognitive Sciences*, Vol.11, No.5
- Gal RAZ; Yael Jacob; Tal Gonen; Yonatan Winetraub; Tamar Flash; Eyal SOREQ; and Talma Hendler, 2013, „Cry for her or cry with her: context-dependent dissociation of two modes of cinematic empathy reflected in network cohesion dynamics“, *Social Cognitive and Affective Neurosciences*, (7) 2013, p. 30-41

- KENNEDY, Denis, *The Spectator and the Spectacle. Audiences in Modernity and Postmodernity*, Cambridge University Press
- MARKS, Laura, 2002, *Touch: Sensuous Theory and Multisensory Media*, University of Minnesota Press
- SMITH, Murray, 1995, *Engaging Characters. Fiction, Emotion, and the Cinema*, Oxford University Press

MIRUNA RUNCAN is a writer, a theatre critic and a Professor PhD of the Theatre and Television Faculty at "Babeş-Bolyai" University Cluj, Romania. Co-founder (with C.C. Buricea-Mlinarcic) of Everyday Life Drama Research and Creation Laboratory (awarded with a three year National Grant for Research in 2009). Author of Modelul teatral românesc (The Romanian Theatre Model), Bucharest: Unitext Publishing House, 2001, Teatralizarea și reteatralizarea în România. 1920-1960 (The Theatricalisation of Romanian Theatre.1920-1960), Cluj: Eikon Publishing House, 2003, Pentru o semiotică a spectacolului teatral (For a Semiotics of the Theatrical Performance), Cluj: Eikon Publishing House, 2005, Fotoliul scepticului spectator (The Sceptical's Spectator's Armchair), Bucharest: Unitext Publishing House, 2007. Universul spectacolelor lui Alexandru Dabija (The Universe of Alexandru Dabija's Performances), Limes Publishing House and Camil Petrescu Foundation, Bucharest 2010. Bunjee-Jumping. Short Stories, Cluj: Limes Publishing House, 2011; Actori care ard fără rest (Enlove with Acting: 12 Actor's Portraits), Bucharest: Limes Publishing House and Camil Petrescu Foundation, 2011; Signore Misterioso: anatomia spectatorului (Signore Misterioso: An Anatomy of the Spectator), Bucharest: Unitext, 2011; Critica de teatru încotro? (Theatre Criticism. Where to?) Cluj University Press, 2015

Trisomic Stages: Theater Hora and Jerome Bel's Genetically Modified Theater

DEBRA LEVINE*

Abstract: *Disabled Theater* (2012) is choreographer Jérôme Bel's performance-based investigation into "how theater is modified when it is done by actors with a learning disability and what theater does to actors with a learning disability" (Bel) By proliferating the codes of theatricality *Disabled Theater* succeeds in intertwining critical reflection and intensive affect. Audiences become uncomfortably aware of how the seemingly mimetic failure of the performers and their child-like vulnerability produce the quality of "presence" that is currently fetishized in live performance. Alongside Bel and Theater Hora, this paper asks whether *Disabled Theater's* production of a trisomic stage and its capacity as a critical affect mechanism might expand theater's disciplinary and disciplining genetic composition in order to homeopathically relieve the art form of its complicity in the project of social normalization.

Keywords: Disabled Theater, seduction, Bel, spectator

*I define the Neutral as that which outplays [d  jouer] the paradigm,
or rather what I call Neutral, everything that baffles the paradigm.*

*For I am not trying to define a word; I am trying to name a thing:
I gather under a name, which here is the Neutral.*

Roland Barthes (2005:6)

During rehearsals, a term that theater scholar Natalie Crohn Schmidt reminds us literally means to "reharrow, [to] go over old ground," (78) choreographer Jerome Bel asked the actors appearing in what eventually became *Disabled Theater* to complete six tasks: stand in the front of the stage without speaking for one minute; say your name, age and profession; name your handicap; create a dance solo and perform it; tell what you think about this performance bow.

* Assistant Professor of Theater, NYU Abu Dhabi, e-mail: debra.levine@nyu.edu

Bel was invited by dramaturge Marcel Bugiel to collaborate with Theater Hora, a Zurich-based theater company composed of professional actors who self-define as cognitively impaired, and perform in Swiss-German. Bel's standard interview reply to the question of why he agreed to collaborate with Theater Hora, is an answer that he rehearses at every press event where *Disabled Theater* is performed. He tells the story of how he was reluctant to engage with Theater Hora and with the theme of "mental disabilities." In the classic Aristotelian structure of reversal and recognition, Bel then tells of his compulsion to collaborate because he, as the spectator, was so affectively overcome upon viewing video documentation of Theater Hora's previous work. That reiterated commentary, circulated worldwide via the internet, functions as the spectator's periperformative introduction to *Disabled Theater*, a staged meta-reflection on the mechanics of how theater produces affective attachments via spectatorship, and the personal, social, and political ramifications of feeling these entanglements. Bel's answer privileges how he was moved and how that affection precipitated an action—it led to his decision to spend time – as he says, "becoming tied up" – in presence of the company even though he had no experience or skills in working with neurodivergent actors. *Disabled Theater* is Bel's effort to cognitively master what moved him.

Jérôme Bel: I [Bel] didn't know anything about mentally disabled people. I knew it [the process of creation] would be very difficult because of political correctness. I would be tied up; it would be very slippery as I have no expertise on this issue. A few days later, I watched the DVDs, and I was speechless. I couldn't believe what I was seeing. Their [the actors in Theater Hora] ways to be onstage were very surprising and overwhelming. I wrote them that as I was coming to perform in Zurich in three months, I would be interested to meet the actors for three hours. After those three hours, I asked for five days. And after those five days, I said I would like to make a piece with them.

Time Out New York: Have you worked with learning-disabled performers before?

Jérôme Bel: Never.

Time Out New York: Could you describe what your ideas were for this piece?

Jérôme Bel: I didn't have any idea at all. I knew I was there because of this emotion I had watching the DVDs. I wanted to know why I had been so deeply moved, I was crying watching them perform. I couldn't explain this emotion to myself, so I needed to work with them to try to understand this totally unexpected reaction. (2014)

The event of *Disabled Theater's* conception is coded differently however for Bugiel, Theater Hora's dramaturge, who publicly represents the company. Bugiel's narrative begins with his exposure to Bel's repertoire and Theater Hora's desire to work with the avant-garde performance maker – Bugiel's is an outreach narrative that precedes theatrical collaboration. One could hypothesize that Theater Hora might have desired to be associated with the avant-garde cultural capital Bel brings to the party, or feels an affinity with his aesthetic. But that would be mere speculation, for Theater Hora's perspective has not circulated like Bel's does. The spectator does not hear it beforehand; the company did not participate in shaping the periperformative narrative on the public stage that Bel was afforded at various performance venues. Already fractured into dissynchronous narratives that are unequally valued and circulated, obstacles that disability studies analysis takes up as critique,¹ biosocial discourse also tells us that dissynchronicity like the operation of these unaligned narratives, when intensively experienced in an individual, is an indicator of mental illness.²

To his credit, Bel foregrounds dissynchronicity in the very dramaturgy of *Disabled Theater* and critically refracts it through a biosocial lens. Using his encounter with the actors of Theater Hora as the paradigm, Bel reharrows how dissynchronicity is coded into the apparatus of theater and refigured as

¹ In particular, see David T. Mitchell and Sharon L. Snyder. *Narrative Prosthesis: Disability and the Dependencies of Discourse*. University of Michigan Press, 2000.

² Dissynchronicity is a term in medical discourse that is identified as a possible symptom of mental illness. What is pertinent to this argument is that in rendering of dissynchronicity in the discourse of human biosociality, the standard literature informs us that "people experience uneasiness or anxiety when the analogic and digital readout of their information coding processes, that is their non-verbal and verbal communication patterns are out of synchrony with those around them. This dissynchronicity may lead to a confusion in the definition of relationships and a lack of predictability in the information exchange system. But, as emphasized Spradlin in *Human Biosociology*, "all information coding systems, ranging from complex social interactions to equally complex inter- and intracellular activity, are continually changing data. The data move from one mode of coding to another, with continuous feedback loops.

http://download.springer.com/static/pdf/468/chp%253A10.1007%252F978-1-4612-6148-3_10.pdf?auth66=1414927476_75d680d04517c3c42d9b76e90fb71dad&ext=.pdf

neutral rather than a social pathology. As a personally felt disjuncture of temporality, dissynchronicity instantiates the leap to a pathologizing diagnoses. But in taking it up theatrically to demonstrate it as a structure, it is foregrounded as the “problem” that Bel understands that he will be entangled.

Following Roland Barthes meditations on *The Neutral*, I will offer an analysis of *Disabled Theater* as an anecdote, antidote, bafflement and feedback loop – a performed and performance-based essay – that detours dissynchronicity and isomorphism. Rather than the viewer finding those qualities through the performer as embodying the disabled subject, the location of the drama shifts. What is enacted on stage instead compels, intensifies, and stages all the processes that consolidate affect into knowledge formation. What happens on stage prompts the spectator to become conscious of the speed, temporality and other mechanism of theater that direct the spectator to judge and evaluate – in essence produce “the problem” that Bel references. Affect is an internal bodied movement that is also a re-harrowing. It happens first for Bel and then in the body of the audience as his proxy.

Because little happens in *Disabled Theater*. Instead the primary theatrical event happens in the mind of the cerebral spectator. *Disabled Theater* transforms the audience member into the “cerebral subject” of the play, a neurocultural term attributed to activist Judy Singer that points to an event – the nexus of “self, sociocultural interaction and behavior” (Ortega 426). Here it is the bodied experience of feeling how judgments and assumptions about the onstage performers proliferate and oscillate, speeding forward to discredited histories and integrating themselves into the present. In sites other than the theater, persistent dissynchronous felt thoughts like what happens to the spectator when watching *Disabled Theater* would be actionable and of great concern. The spectator understands that. So too would thoughts that dizzily individuate, aggregate, and then individuate once again like the fast forwarding the repetitions of a soloist emerging from the chorus and returning to the group and becoming indistinct.

But theater is malleable in its capacities to work with and against itself as Bel demonstrates, for it is lauded as an apparatus that can mobilize thought’s dynamics, and in different mixtures and quantities. The skill that Bel brings to it is that his project is to think about recoding to destabilize the pathologizing subjectivization and social devaluation. Bel, Bugiel and the actors appearing in *Disabled Theater* collaborate to refigure theatrical conventions so that they entangle and baffle the spectator in the knottiness of her or his own thoughts. In using the theater to cognitively overload the spectator to the point of paralysis, Bel also makes an opening for the subjects of the dispositif or the theatrical

apparatus that makes disability a habitus to shift their position within it. Some performers make their way to its margins either voluntarily; others are moved out forcibly. Others, more or less like Bel (more) and Bugiel (less), who ally artistically ally themselves might change coordinates. The work offers modalities of theater that conceive of an aperture in which to imagine the theatrical equivalent of the aphoristic writing in Giorgio Agamben's coming community – where the formal techniques can muddle subjectivization so that valuation and classification are drained of their political utility.

Disabled Theater takes up cognition as its subject. What happens on stage with actors who labor under the broad category of cognitive disability compels the audience members, like Bel before them, to become conscious of the speed and variability of our own mental processes. The production places neural self-awareness on an intimate and personal stage. It is structured to create a reaction in each spectator where her thoughts become spectacular and singular to the thinker. But the experience happens communally and synchronously, to each among others. Reversing the material stage as the location of action and making it immaterial, while and affective heightening temporal consciousness in each spectator's mind before it coheres into a discursive feeling, baffles any common interpretation or easy reduction of the work. The force generated by becoming conscious that this meta-reflection is all taking place in one's mind, enervates rather than mobilizes. The work creates a paralytic affect state where the energy of the audience members is directed to conscious contemplation of the interdependence of culture and cognition. What the spectator "sees" and "perceives" in her own mind is how theater assists biology and genetics by showing performing bodies that instantiate the conventions and behaviors the sciences have identified.

Disabled Theater genetically modifies the theatrical freak show by sidestepping the normative carnivalesque and the avant-garde genres through which historically it is most often cast, constructed and critiqued. Quite startlingly instead, *Disabled Theater* uncannily replicates the ontological, aesthetic and economic theatrical model of the backstage Broadway musical *A Chorus Line*, a work that isomorphically reiterates and proliferates theatrical coding. Bel's formal aesthetic interventions act to confound – not invert – the bright lines of genre paradigms. The redirection makes a claim for a wider contemplation of theater's unmarked normativity as a freak show and as technology that assists biological and genetic discourses in becoming coherent merely through the everyday display of selecting, grouping and individuating social subjects.

While theater becomes the exemplary mechanism to naturalize the social effects of disciplinary discourses, Bel is not content to merely reiterate that Foucauldian critique or settle for Judith Butler's assessment that the effects of performativity on stage do not engender the same social impact. Attentive to Butler, the collaboration between Bel and Theater Hora undoes code with more code – highlighting the importance of shifting quantities. This strategy alters what singular or foregrounded codes compose. Bel adds in theatrical codes in homeopathic doses to alter historical dramaturgical structures. During the performance, the audience becomes destabilized – they experience a qualitative change in themselves which occurs when different applications and quantities of genetic modification are performed to theatrical conventions that usually set to default to a primary action—that of reducing singularities to categorizable subjects when bodies appear on the stage.

How does code disable code by proliferation? In *Disabled Theater*, Bel takes up the actors of Theater Hora because they are overdetermined. Over determination depends on coding quantities, proliferation and terminology muddles. The actors' association with Theater Hora already classifies them as subjects of and foregrounded through neurodivergence; in the show the performers are made to speak of their materiality through the conventions of confession, analysis, and audition. Some, but not all, speak of their genetics, and self diagnose. All these conventions are theatrical conventions – coding mechanisms that classify, group and reduce subjects. Actors and translators are made to tell and exemplify how distinctive stage identities are embodied and where they are located under the sign of divergence. They reiterate how varying diagnoses cohere through past discredited observational measurements (like phrenology or phenotype) and that progress in science and medicine depends on other still validated measurements such as kinesthetic and specular evaluation. Without comment or judgment, *Disabled Theater* calls upon the proliferation of pathologizing historical and contemporary diagnostic discourses still in play to show that while conventions of valuation may change over time, demonstrating the value of valuation that is theater's genetics.

But when code is unspooled on the stage, activating a proliferation of both discredited and validated, their quantity and adjacency baffles any one's singular programming. Proliferating cognitive frameworks shift where stage action locates itself, concomitantly unspooling in the mind of spectator. And by happening all at once, valid and invalid bleed into each other. That

indistinction veers toward the pathological; allowing synchronous thoughts to appear as adjacent. The outwards spatialization and flattening also unspools the logic of their irrationality. The spectator feels how the mechanics theatrical organization calls upon appearances, sorts and individuates in order to confer normative value. *Disabled Theater* invalidates that paradigm – at least somewhat – for it shows and invests in codes that capaciously include paradoxes and aphorism; showing how theater is *not yet fully* determined or determining of truth and still produces it. The production also suggests that as codes become transparent, adding others can disarm them. From this formal operation, *Disabled Theater* suggests how there may be a possibility of refiguring neurodiverse biosociality. Acting as a pedagogical coding machine, *Disabled Theater* demonstrates some of the operations that can be done on, with and beside the theater – within singular performances an/or periperformatively – and that these operations also produce different framings and outcomes that baffle the unidirectional choreography of singular focus and individuation that sends spectatorial thought hurtling toward diagnosis and prescription.

The effects of these code proliferations can alter the circumstances for the performers – but differently than the spectator. The exercises that shift and affectively overwhelm the audience can also function as a diversionary tactic for the overdetermined performing subject to revise modes of embodiment and self-presentation. *Disabled Theater* foregrounds a score over a fixed script, to accommodate for improvisatory isomorphic shifts between being and performing. Although the show is bounded, who retains the authority that determines those boundaries seems to be a constant negotiation. I noticed that the performance makes no physical disciplinary requirements of the performers like the commercial theater, which sets and freezes the actions and the visual appearance of bodies performing those actions.

An observation: Over the first year's run of the show, original *Disabled Theater* cast member Miranda Hossle appears to have lost half of her body weight between performances in Kassel Germany in 2012 and when I saw her perform in Milan in 2013. I interpreted those changes in embodiment as profound, and connected them to how she authored and altered her projected stage image. In the fourth action of the show, when Hossle is called upon to dance the Orientalist solo she choreographed for herself, using a shawl as a prop, her work in Kassel uncannily reminiscent of the dances American choreographer Ruth St. Denis's created for herself after seeing the image of the Egyptian goddess Isis on a poster of a Turkish cigarette ad. Dance critic

Deborah Jowitt explains this for St. Denis as a “becoming an icon of her imagined other self” (130). Hossle’s dance – the first of the seven in the fourth sequence – destabilizes the canard that an individual’s true singularity – or presence – can be accessed through kinesthetic expression. But movement can also be read as the means toward an aspirational embodiment. Hossle does not disclose whether her reiteration of a colonial fantasy is a conscious comment on Orientalism or on femininity – and as an audience member, my default mode of cognition is to question her reflexive capacity merely because I am seeing the work in the context of *Disabled Theater*. I have never applied the same mode of questioning to queer avant-garde performer Jack Smith whose own “presence” in his Orientalist kinesthetic embodiment was drawn from Maria Montez’s B movies, for unconsciously I grant Smith “normative” cognitive function.

But while I am wrapped up in my own reactions, other things happen that most audience members would not seek out. In the Kassel performances, I linked the amateurish mimicry in Hossle’s dance performed at twice her later weight to her neurological capacity. In Milan, where I first saw Hossle in person, before the show began, I was unclear as to whether she was even an actor in the company. I could not read any visible presentation of neurodivergence, and her dance, I experienced that that performance like dance karaoke – more like imitation Shakira derived from repeated Youtube viewing than St. Dennis. My linkages speak only to my own projections and systems of aesthetic valuation – many of which I find somewhat shameful and which this production forces me to reflect upon. Bel later told me that Hossle’s effort to lose weight was deliberate and part of her strategy to separate herself from the company. In the time between the first performance and the last, I don’t know if Hossle’s self-diagnosed “handicap” has changed – it didn’t when she said it in the third action of the show, but because of my repeated viewing over the run, I was privileged to watch a cognitive process occur, where being on stage and touring the world with the company allowed Hossle to determine how to become normatively indistinguishable and extract herself from the paradigm she performed – from being primarily valued for her capacity to express the over determinedness of “disabled” or “handicapped.” Not everyone has the luxury to become indeterminate by means of camouflage because of the similarity of observable external features and bodied movements that have been linked to genetic coding. But neither is that flexibility is not afforded most performers in the commercial theater either who are cast by “type.”

So many codes cannot be neutralized quite as easily through the collaboration's modifications—that is the limit of this production – not just to refigure the social but in the practices of theater. But the labor speaks to the becoming more conscious of theater's varieties of possibility. By concentrating on the set of conventions and practices of theater as a *dispositif*. I was able to fashion a “non-normative” spectatorial engagement with this piece. I slowed down my rush to judgment and saw the production three times over the course of a year and a half. What I write here cycles through the observations I accumulated by seeing *Disabled Theater* as a show that “runs” over the course of time and what is performed in the first evening is reiterated in two different locations, in first in Milan and later Singapore. I also interviewed Bel at the Frieze Art Fair in London in 2013, and read several recent scholarly analyses of the work. I admit right off, from the moment I heard about the production, I was captivated. And I continue to think and write from that position. In Milan, before I saw the show, I spent several hours in the café engaged in a chance meeting with the actors and felt entirely welcomed – enchanted by the company. That feeling lingers and it feels rueful and sweet.

In the year between my first viewing of the show in Milan and my second and third in Singapore, Hossle and Lorraine Meier, the latter whose wild-eyed and angry speech about her handicap was probably the most singular shocking moment in the show every time it was performed, have disappeared from the production. While Hossle left of her own volition as her body thinned and became more aligned with normative standards of beauty, I don't know what happened to Meier. Meier was one of the older members of the cast. Onstage, she identified herself as in her forties, and presented as a difficult and tendentious stage personality. In Milan, when asked to say her handicap, Meier was the only one that made me flinch. As she stepped up to the microphone, she uttered, “mongoloid... I am a fucking mongol, or sometimes not... It hurts me.”

The complex racialized effects of that perjorative term were palpable; the utterance did not offer the audience some intellectual breathing room. Instead the speech act interpellates an observation—my knee-jerk response was to stare at Meier's facial features. She masterfully directed the audience to participate in the *dispositif* which exposes itself in this encounter. The phenotypological kind of staring Meier commanded a stream of mental associations for me – in essence it made me soliloquize, and I became the performer in my mind. But I was also aware of my impulse control and that I repressed speaking my thoughts aloud. I thought about how that mode of

looking has been the source of great historical injury. I thought about how looking back at Meier made me feel awful – and even worse now as I write and time passes. Rationalizations still sped through my brain to quell the waves of anxiety. But I also ask myself about my desire for Maier to repress her act, and conclude that my wish for her to mask her enacted response stems from my keen absorption and compliance with my own normative theatrical comportment. Meier was so far afield from how I identify or value her act as mimetic. What she did broke the rules of the stage that allowed audiences to comfortably engage with the action without enduring real consequences.

Meier's reply most likely did pain me more it did her at that moment, for Meier was felicitously doing her job, which was to replay herself in her first encounter with Bel. Miranda Hossle tells us as much in the fifth operation of the Disabled Theater scenario where Bel asks the actors to tell what they think of the play. Hossle said her job as an actor was to play herself. But I am sure Meier would not get cast if she was only an actor. Bel needed a double threat (in the Broadway musical a double threat is a dancer who could sing, a triple threat which often made one an individual star is a person who could "do it all" – sing, dance and act. Following this logic, all Theater Hora actors are triple threats. The other collaborators like Bel and Bugiel are not.). The double threat (which can be taken as a social threat or challenge to the social norm) of this particular production called for all performers to be legible as specific genetic material *and* to act. This was indeed threatening; my discomfort persisted, as I struggled to remain present to the multiple sensations, which included nagging doubt and the unquantifiable feeling that Meier was at least able to make a living as a professional actor – not just because of neurodivergence but because she looked her age, and female actors this old in the commercial theater are not afforded longevity unless they are virtuosic. I did not speak my internal thoughts aloud then. I do so now in this scholarly paper, the arguably proper venue to release these concerns and still appear "normal."

Observation. When I went back to see the show a year later in Singapore, Meier and Hossle been replaced with two much younger and sweeter looking performers, Fabienne Villiger and Remo Zarentonello. Villiger and Zarentonello both identify their handicap as Down's Syndrome. Neurodivergence doesn't seem to be a limit to what normalizes this work as much as age and specular gender conformity. And, although the structure of the work does not compel the new performers to repeat the words and acts

of the older departed performers, they retain and lim the initial performers' styles and attitudes. But in this new iteration, the wild improvisatory quality of Hossle's disdain and boredom and Meier's anger are tempered. Villiger and Zarentonello fit almost too easily into the performance style that has already consolidated itself and become normalized – so much so that the third new addition, an older actor, Nikolai Gralak in the “tell what you think of this piece scene” offers a masterful deconstruction of the work that is far better than the piece of writing you are reading right now. The adapted performance seems to have settled with the new coding of Villiger, Zarentonello and Gralak, detouring the work back to a now comprehensible theatrical model. The odder racial and colonial traces in dances and choices of music in the dance solos are evacuated – Zarentonello virtuosically dances a Cossak number that looks like the break out solo after a few drinks at a wedding, and Villenger's crowd-pleaser echoes Miley Cyrus's coming of age rebelliousness in her performed boxstep to the Abba hit, “Money, Money, Money.” Villinger chose Abba as did Meier in her dance solo choreographed to “Dancing Queen.” But while Villenger dances in a restrained fashion and her capitalist critique is an easy crowdpleaser, Meier intensified the spectators's uneasy pleasure of enjoying her unrestrained and ecstatic dance because she complexly coded disorder and bafflement into the trajectory of her stage persona and again in her choreography.

Substituting Zarentonello and Villinger for Hossle and Meier, drained the affective charge of the work that seems to have been encoded in the original rehearsal. The rehearsal was a process which Bel conceived as an encounter – for him it was a – which in reflection cannot merely be a rehearsal for it seems, from what the show has lost, that the initial even was one where everyone struggled with Agamben's “whatever singularity” of all who were adjacent to one another in that room, during that period. But Hossle's transformation in plain sight over the course of the run indicated that this was not her objective nor what she most valued – for Hossle this work became a mechanism through which she could become physically indistinguishable outside of the theater and performatively illegible.

This goal sits uncomfortably on the spectrum of disabilities culture, for a genetically modified theater offers the opportunity to become less recognizable in relation to prior subjectivisation. As the spectator's cognitive circuits are scrambled – or at least and consciously felt as such – and simultaneously heightened as kinesthetically the body becomes less mobile – the spectator (and the critic's) preoccupation with neurological introspection and concomitant

paralysis provides an obscured and potential opening for the performers. What performers do with those opportunities may not be considered either normatively liberating or progressive. But because the performance directs the spectator to contemplate the proliferating codes without hierarchical value in a concentrated metaeflexive rush that directs the spectator to a present experience of how past cultural influences are neurologically embedded – some performers take advantage of that arrest to performatively obscure and un-differentiate themselves and become less recognizably “divergent”. Feminist scholar Gayle Rubin mined this territory to propose the term “benign variation” as a way to radically revalue stigmatized acts and the bodies who perform them.³ This radical notion seems necessary and unachievable. I what I am instead arguing here is that the genetic modifications of the theater by *Disabled Theater* provide for fugitive strategies of camouflage and flight because of the obscuring expressions associated with overdetermination. There is a choice to risk engaging these strategies like Hossle did, or submit to their lure like Maier. And both become cautionary anecdotes that demonstrate some values, practices and risks of indistinction and of the logic of capture.

Observation. *Disabled Theater* is organized as a series of anecdotes, much like the musical theater production it most resembles, the original 1975 Broadway production of *A Chorus Line*. The anecdote is a form, according to Roland Barthes, that relates something that is “impossible to put better” – in this performance it is also a confessional (36). And, what baffles us most in an age where irony still is the default of the avant-garde in the theater, is that the show is sweet. Sweetness, Barthes writes in *The Neutral*, is a form of tact. *Disabled Theater* seeks out a form of nonviolent refusals of reductive and actionable critique and instead grapples with neutralizing codes of performance in order to expose a twinkle (Barthes’ term) of singularity. Tact’s hallmark is

³ Feminist scholar Gayle Rubin, in her 1993 article, “Thinking Sex: Notes for a Radical Theory of a Politics of Sexuality,” argued for political necessity of reordering the hierarchical system of sexual value as the possibility of political and social change where specific behaviors are linked to social status through “an excess of significance.” The radical solution that Rubin envisions is a pluralistic “benign spectrum” of consensual acts in which all are allowed to “exhibit the full range of human experience” and none are “still viewed as unmodulated horrors incapable of affection, love, free choice or transcendence.” Following Rubin’s logic, appears that Bel with Theater Hora is experimenting with the ways in which to excavate all the impediments to Rubin’s vision of a benign spectrum through his constant reharrowing of the apparatus of the theatrical chorus line and the individuation of the soloist (which marks the emergence of Western theater from the Dionysian dithyramb) to envision a trisomic stage as the means to its production.

inventiveness and particularity toward the intersubjective encounter. Barthes writes, "each time in my pleasure, or my desire, or my distress, the others discourse (often well-meaning, innocent) reduces me to a case that fits an all purpose explanation or classification in the most normal way, I feel there is a breach of the principle of tact" (36). *Disabled Theater* becomes a mechanism that demonstrates and navigates the expressive apparatuses of tact's breach as well as how it might be modeled – while it paradoxically tangles with the slipperiness of how those discursive and nondiscursive operations are naturalized as and in theater's genetic codes. What confuses me still is whether, thinking with *Disabled Theater*, one can modify theater enough to remedy it homeopathically.

The slipperiness of this endeavor, as Bel notes, comes an avant-garde wariness or refusal – to become captive to something. In the recent history, the "normative" aesthetics of theater veered far closer to what Brecht outlined (but evacuated of his politics) which dovetail with a neoliberal doctrine that espouses and values the autonomy of parts, shows that can be excised from their context or even their original medium, and an alienated stance between the creators to the work. A first or any superficial glance at *Disabled Theater* can easily find the locus of objectionable content as Petra Kupperts does in her recent TDR article, "Outsider Histories, Insider Artists, Cross-Cultural Ensembles: Visiting with Disability Presences in Contemporary Art Environments" (2014). But Kupperts begins the article by an elision, to which the publication lends scholarly validity, that she has not experienced the work firsthand.

Alienated from the scene of the theatrical event, Kupperts takes up the privilege of the post-modern scholar, grounding her decision to abjure seeing the work by citing a proxy contact, Nadja Sayej who (by my interpretation of Kupperts's quote), did not so much as dismiss the *Disabled Theater*, but instead carefully recorded how she and the other audience members were baffled, disturbed and angered by the experience. But Kupperts uses the description to validate her methodology, checking Sayej's narrative against other un-cited web accounts. For the time she spends on that investigation Kupperts could have attended the live show but instead concluded from that internet research that the production lacked "anything that is informed by disability culture values, by a questioning of medical diagnoses, or by an interest in disabled people as more than just the representatives of disability" (32).

I am not chastising Kupperts for her choice. In her footnote she clarifies that her earlier work has addressed the "'victim art' routine extensively and she is moving away from that mode of criticism in order to catalyze the

field of 'social practice art'" and, she does give herself "an out just in case I get to see this piece live, and am seduced by it" (36). She makes an energetic effort to avoid seduction and the decision to avoid the project but put it into discursive play then depends on excised public relations videotaped documentation available to be taken up and circulated in an alienated manner and mediated form. The validity of this method and the questions it raises – how does the theatrical event become rendered into dislocatable parts? Does that circulation effect a new reality? Is it a different or extended event?

The dramaturgy and mechanics that enable us to ask those questions about Kupper's methodology can be traced back to Brecht and Walter Benjamin. Theater as a live and synchronous event, where what is shared is shared all at the same time among those in attendance can be thought otherwise through dramaturgical conventions and new media technologies. Because *Disabled Theater* insists upon the playing out of all the mechanisms and conventions both internal and seemingly external but adjacent to the theatrical event that sanction exclusionary behaviors, Kuppers becomes entangled too – she is caught up in the theatrical dispositif that Bel exposes. Dispositives depend on binary associations to create modes of and allegiances to identification and identities – and so even as it critiques the paradigm, it produces evidence of its power. *Disabled Theater* and Bel become Kupper's straw dog against which she articulates the difference of cultural production where disability culture meets social practice art. But the utopian strategy in *Disabled Theater*, whose completion is always deferred, is that it labors to outwit binary paradigms by foregrounding the conventions upon which they depend, and exhausting them of their meaning, as Andre Lepecki writes of Bel's project in his earlier performance work.

And, why hold back for fear of being seduced or captivated? Why avoid the seduction, which in the case of *Disabled Theater* allows the spectator to experience the frantic tarantella of codes, histories and periperformatives of disability's dispositives that theater has produced and which dance in the mind of the spectator? Brecht is the fallback here – where alienation becomes the paradigmatic position from the spectator could analyze the information in a dialectical fashion and from that synthesis, formulate a logical social response. Better to begin to catalog the additional dangers to these uncomfortable pleasures that Brecht didn't flag, not the least is an almost masochistic spectatorial paralysis induced through these dizzying oscillations – and adjacent to that is pleasure of cohering as an ephemeral and temporary community bonded only by this experience of discomfort – not via Aristotelian

identification. For as Koppers relates, her informant sought refuge from the audience members around her, "looking at each other, wide-eyed in awe." And so the question becomes, if one remains captivated and captive to the production and as it was with me, revisiting the work over the course of its run, might I recode the exclusion of Bel from the field Koppers is working to promote?

In *Entanglements, or Transmedial Thinking about Capture*, Rey Chow looks back to Foucault and begins her text with a quote from *Dits and Ecrits*. Foucault notes the task the contemporary philosopher, and of philosophy itself, could well be to analyze the matrix of entrapment and reflect how philosophy is captured inside it. Chow asks, "What are these relations of power in which we are caught and in which philosophy itself... has been entangled? (Foucault in Chow: 1). For Bel, theater, becomes the exemplary dispositif through which to process that question, for it gathers together heterogeneous elements and historically it has been the mechanism that consolidates and performatively naturalizes concepts, categories and identities on real bodies through specularly, embodiment, affect, and discursivity. Theater produces and instantiates categories by means of visible, speaking and dynamic bodies and is reiterative over time; theater also comes to represent and reiterate those categories and structure. Dispositives such as theater are spectacular conjoining mechanisms.

But Chow presses her reader to consider entanglement differently, where "entanglements might be conceivable through partition and partiality rather than conjunction and intersection, and through disparity rather than equivalence" (2). This refiguration of association follows dispersions, lines of flight, and recaptivations at paradigmatic sites like theater, where someone – perhaps that would be Bel or myself – willingly submits to becoming captivated and captive. This submission allows us to ask whether theatrical reharrowing might reframe or offer up different ways to follow or pose the consequences of the dispositif? Via readings of stories and films where, "we encounter fictional characters who can easily be labeled mad but whose madness, or state of being captivated lends the stories their perverse psychological textures," Chow revisits these cultural productions to investigate how proliferating, baffling and paradoxical entanglements of forms immobilize against good logic or even self-preservation (6-7).

Kafka invented the most famous harrow, an imaginary wooden contraption that immobilized the condemned, and was designed to puncture their bodies, draw blood that spelled out their specific juridical sentence.

The prisoner was unable to see the written text on her body. Instead, knowledge was conferred by the piercing of the needles slowly over time. The mechanism's pedagogical function was linked to the way that it functioned as theater. Without the body of the sovereign present, the harrow was an instrument of governmentality that depended on theatrical spectatorship. In the story, both audience and the prisoner became enchanted over a long *durée*. The mechanism broke down (an early case of planned obsolescence, upon which commodity fetishism depends) close to the story's conclusion but not before the prisoner's body (in which the final captive is the harrow's former designer and operator) expired in a state of agonized transcendence. The story concludes with the citizen's call for a better and more compassionate technology and the narrator's, narrow escape from the town, first to the island's perimeter, inhabited by the town's outcasts, and then to a boat which we presume takes him to somewhere different so that he can recount this strangeness of this tale. Kafka's rendering of captivation, capture, self-annihilation and a singular a line of flight made possible by means of narration poses the question of how or even whether to outplay a paradigm via a mechanics of narration? How does Kafka's anecdote reveal the effect of discursivity and coding, but refuse the companion fantasy of explaining them away or fully evading capture? Kafka's story is memorable because it reveals all the codes of the paradigm and is neither a story of progress or uplift or morality. Instead, and almost clinically, it describes a paradigm where justice, writing and bodies come together and we readers, as the narrator's proxies, circulate within and around that lure.

In *Disabled Theater*, Bel reharrows theatrical mechanisms for the purpose of bafflement. It isn't a question of *how* to experience Bel's coding and circulation of how he took on the company's actors as theatrical subjects and adopted the audition format as a dramaturgical structure to rehearse his project of investigating the theater as an affect mechanism and an apparatus of cognition. It is whether the leap can be made to recognize it as a poetics of captivation and to ask whether that position enables or allows all imbricated in that matrix to approach what Agamben calls the "whatever" being (1.1). For example, Kupper allows herself to caught up in a normative economy of production and circulation where *Disabled Theater* is viewed only once and contemplated with a number of other works during one exhausting day at an art fair such as Documenta (where Koppers could be didn't see the work) or a performance festival like New York's Performa (where Leon Hilton, who writes a sympathetic and careful engagement with the work does) or the

Uovo Festival in Milan (where I first saw it and which programs “unruly” works) or at the Singapore Festival of the Arts (a city which is the antithesis of unruliness and where I last saw the performance). Those modes of presentation have their own will to political, cultural and economic power. But in the hit and run muchness of the festival or fair, the work has to be “gotten” for its content quickly. In that particular mode of reception, Bel’s complicated intent is reduced and the cognitive processes it interpellates is stunted. For me, engaging repeatedly with the *Disabled Theater* over the long dureé, I find that captivation multiplies and opposes the foreclosure of the experience.

Instead an open-ended engagement and captivation with theater’s subject, histories and mechanisms opens out to all those captivated in *Disabled Theater’s* isomorphic structure. There seems to be something of value – for all parties –including the value of risk – which is only afforded to subjects who have some agency in the situation. The long dureé also allowed me to experience how the production outwits a reductive reading of genetic discourse – both theatrical and human bodied – that eradicates the possibility of experiencing the glimmer and twinkle of singularity that may produce very concrete lines of flight. In this case I note that singularity is made through these isomorphic staged moments where, following Agamben’s quote in the epigraph, the common properties of all parties involved become more indistinct through this set of operations.

While the production of *Disabled Theater* retains a trace of dramatic plot, enhanced by Bel’s periperformative that directs the audience in Aristotelian fashion to emulate the journey of Bel’s reversal and recognition of devaluing value. (A cast member, Gianni Blumer, breaks the code of normal theater where one doesn’t publically complain about one’s director, and instead, uses his onstage confessional stage moment to complain about Bel’s elimination of his dance solo during rehearsal. What happens next, without explanation, is that the excised dance solos are reinstated right before the final bow). That reconsideration of a directorial choice seems to place Bel as the protagonist of the piece moving from that state of incomprehension to reconciliation or synchronization with his affective register. But the work takes the principles of performance to incorporate other structures that make an apparatus that is useful for the actors and not merely for Bel or for the spectator. Bel foregrounds those as well and so there are possibilities for the images and the performer’s release. Almost every moment of *Disabled Theater* is YouTube ready. Each time an actor steps up to the microphone to answer one of the questions above, or

takes the stage to perform a dance solo, the event could easily be extracted and circulate as a performance vignette. Each of the six operations listed above function independently. But Kupperts shows the significance of the partage's recapture.

Bel's choice of their order and aggregation hearkens back to the format of the Broadway musical, *A Chorus Line*, a work celebrated for its break with commercial musical theater's dependence on a progress narrative and for the original production's struggle to offer cultural and economic credit to the performers whose life stories served as the basis for the performed narratives. *Disabled Theater* and *A Chorus Line* share the same order: show oneself, identify oneself in terms of the state, confess to the way one self-identifies, display one's taste, virtuosity and spirit through movement, reflect and finally, cohere into a group. Because of *A Chorus Line*, this order appears natural and yet could easily be differently aggregated. This moment-to-moment assemblage is anti-Aristotelian and does align with Brecht's fractionalization of perspective that can be cut up, collaged and repurposed.

But Bel is too clever merely to reiterate the Brecht vs. Aristotle throwdown, or rework *A Chorus Line* into a neurodivergent rendition of the backstage musical. But Bel hearkens back to theater's genetics to play on the codes a *Chorus Line* naturalized. *A Chorus Line's* enormous popularity was partially attributable to its oscillation between actor and character, set and stage, life story and staged narrative. Bel, as in all his projects, foregrounds the codes of dramaturgy and theatrics to make its effects visible to the spectator whose will is brought to bear on the process – like the spectator's drive to make the disjunctive cohere and the artist's choice to work within a medium that synchronizes. Moving the isomorphic action from the stage and into the mind of the cerebral spectator is Bel's trisomic shift – a way to add more code to theater to create it as a machinery that can approach becoming indifferent to the common property that disability as a dispositif makes coherent through embodiment – it is his effort to address theater's effect on the bodies that are aggregated by thoughts that theater directs to reaction in a predetermined manner. This production expends a great effort to achieve that goal, and yet it still it can be read also as an uplift and progress narrative that cannot get to "the fragile moment of the individual" which is to say the presentation of singularity. The best the show can produce is that all professional actors as indifferently "special," – not as neurodivergent, but as actors – much like the principle dancer Cassie who retreats to become a member of the chorus in *A Chorus Line* insists.

Disabled Theater demonstrates that even the liberal and seemingly well intentioned gesture of direction is an exclusionary act that eradicates the drive to represent the "being such that it is" of Agamben's coming community. The spectator can only reflect on that idea by witnessing representation's failure – through the contemplation of Bel as protagonist's inventive efforts to baffle the theatrical codes and conventions and capture those flights. The contemplation of conventions becomes even more heightened for the spectator because in so much of this work Theater Hora's actors with Bel succeed in reconfiguring dramaturgy enough so that it moves the spectators closer to what we cannot capture – it almost but not quite touches the indifference that Agamben identifies via creative re-figuration of discredited and naturalized codes. The audience get a twinkle of how singularities might be valued only for their "being as such" and not in identity terms.

To make this happen fully, *Disabled Theater*, suggests that we leap into the machine. Bel almost, but not quite, makes that leap, and I follow, as Bel's proxy. We experience what happens when one consents or becomes willing to be mesmerized and captivated by the twinkle of discredited binding mechanisms such as identification, empathy and compassion. From this immobilized position and when captivated in this manner, what plays out in one's mind are one's own cognitive linkages between the stage action and discredited racist, sexist, ableist and cultural fantasies. Ugly feelings, as Sianne Ngai observes, may be understood as an index of how those logics linger in and emanate from in the realms of our consciousness because affect, when it rises to the level of discursive feelings, has come to be recognized via those very dreams and fantasies upon which our fantasy of self and identities rest.

Chow notes that a formation of community coheres, a singularity based on the annihilation of the fantasy of the subject that almost incomprehensibly depends on a deeper and deeper plunge into the logic of capital and neoliberalism and asks about its cause and its potential.

By what exactly are these characters so captivated (...)? Is it sheer coincidence that these memorable tales of captivation, with their protagonist's characteristic propinquity toward bondage, masochism, and self-annihilation, have emerged amid modern contexts of conflicting allegiances? Should such bondage, masochism and self-annihilation be taken for a final enclosure or an anarchical opening, a recoiling of the self into... the infinite? (7)

Then the question of *how* to experience Bel's coding and circulation of how he took on the company's actors as theatrical subjects and adopted the audition format as a dramaturgical structure to rehearse his project of

investigating the theater as an affect mechanism and an apparatus of cognition becomes a different task. From the vantage point of attraction and capture, it becomes easier to experience the fracturing of the fantasy of the autonomous self through a poetics of captivation. Then the apparatus better reveals itself. Without being captivated and paralyzed, all practices and discourses are automatically valued and ordered, upholding the paradigm that traps both spectator and critic in generating normative analyses. For me, engaging repeatedly with the *Disabled Theater* over the long durée, I experienced Bel's willingness to become captivated. It also allowed me to experience how the production outwits a reductive reading of genetics that eradicates the possibility of experiencing the glimmer and twinkle of singularity – one which may produce lines of flight where singularity, following Agamben, can become indistinct and valued as “a being such that it is” through this set of operations.

Moving from the abstract to the concrete, I will isolate one moment of this work – but there are so many others – that illustrates how Bel's effort to achieve this phenomenon operated. All of the dialogue I quote was scribbled in my notebook during the course of the third and last time I saw the production, in Singapore in 2014, which is important only because my method of remembering is indistinguishable from Remo Beuggert's.

In the third action, when Bel asks cast members to step up to the microphone one by one, and say what they believe their handicap to be, the translator, Chris Weinheimer first calls Beuggert. Beuggert steps downstage and says “my handicap is that I have a learning weakness. That means I can't remember a thing. For example, when I have to pass on information it gets lost. I leave something out. I mix it all up. What I started to do recently is write down into a little notebook so it doesn't get lost. Okay then, I am a bad messenger.” (After each speech, Weinheimer translates the actors' speech into English. He flags that mechanism at the beginning of the performance when he explains that Bel needed a translator in rehearsals because he did not speak Swiss-German, the actors' native tongue. That mechanism is reharrowed onstage through Weinheimer as Bel's proxy.) Next Matthias Brucker is called. He says, “I have trisomy 21 and I have as well a mentally handicap.” Fabienne Villiger follows. “Okay then. I have Down Syndrome. So what?” Tiziana Pagliaro. “I don't know.” Then Damian Bright steps up to the microphone – six more actors will succeed him after he steps away and rejoins the cast, who are all casually sitting upstage in a semicircle before and after their turn at the microphone. Bright says exactly the same words

as he did in 2013 when I first saw the show in Milan. He noted that his handicap is Down Syndrome. He tells the audience that it was named after John Langdown Down, and also called trisomy 21. Then he smirks and his eyes twinkle as he interprets those fact for our benefit: "That means I have one more chromosome than you."

From my vantagepoint in the audience and among the parade of disability's proliferating discursive frameworks, I think not in succession but so rapidly I cannot distinguish the overlapping thoughts: does Bright smirk because he does not comprehend how he misapplies capitalist values (where more is more) to the way most of us in the audience prize the fewer copies of the twenty-first chromosome which we value to maximize our cognitive capacity? Or is it just that Bright's timing is off? Maybe he is aware that he will get a laugh but he is not so virtuosic an actor that he can mask that anticipation by suppressing the smirk? And (or but), can one characterize bad acting as a disability, except when it happens in the theater? But (and, and) when one is in an avant-garde performance like say, Richard Maxwell's, that tenant doesn't really hold, right? Maybe Bright just doesn't value the comedic stage convention of acting "straight" like I do. Maybe it's Bel's logic. Or maybe I misinterpret that Bright's conflation of the logics of capitalism with the logic of genetics is deliberate and I should feel shame (which I do and which I feel emanating from those around me) for my assumption that irony is beyond Bright's capacity to convey. For the entire theatrical production, Bel depends on proliferation of associative thought which becomes a mode of bafflement. Bel works with theater's delight in isomorphic structures that too easily link to the logic of capital. I also feel delight in this junkie's rush of felt thought which for me is often is the delight of the theater.

This attempt to capture my cognitive loops and to make sense of how Bright, in collaboration with Bel, released what I would, at other times and in other places, view as obsessive and pathological knot of cognitive logic and a dense web of shame doesn't explain its effect on me as a viewer. The isomorphic tangle immobilizes me in and with felt logic and the logic of feelings. Over and over, what the staged actions of *Disabled Theater* elicits through an affective engagement with the actors who foreground how they are perceived through the discursive and nondiscursive linkages that genetic coding elicit, are these simultaneous cognitive operations. They prompt the spectators to contend with how the operations of the theater has naturalized and assigned value through a deployment with conventions that link to

other dispositifs, and how it does so through the specific coding of that elicits and names bodied expression. But the effect is getting caught in a trap – and quite possibly, while Bel cannot baffle enough to fully outwit the paradigm in which we are caught up, the work is a gesture toward the necessity of the effort and the future possibilities of theater's transformation.

Barthes notes that "The Neutral" is a fantasy and what may be most exciting in that figuration is its gesture to the utopian. In this case the gesture is filtered through Giorgio Agamben's insistence on reevaluation of value by Agamben's linking the "whatever being" to the indistinct figure of speech exemplified by the adjective "coming" and the undoing an identity based "community" that sorts value. It is in this space that *Disabled Theater* does not merely serve as critique but instead becomes productive – after Bright I would name this strategy, "trisomic" – an operation of augmentative genetics. "Coming," as gerund form, emphasizes formal indistinction (being a non-finite verb that can function as a noun or as an adverb or adjective and which, in its Latin root demands an action, for it means to be carried out) as a praxis. This coming of a different mode of inhabiting and navigating the tensions between distinguishing and becoming indistinct is "slippery" also when it comes to obliterating categories that have been socially and politically injurious and can be taken up to insist upon forms of redress. This goes to the heart of Petra Kuppers critique of Bel in particular, and the avant-garde in general, which has sought out the materiality and the embodied behaviors of actors that index neurocultures and physically divergent biosociality to think through aesthetic forms.

Linking these categories to embodied acts as evidence of symptoms that can devalue social status can be attributed in part to the theater as a visibility machine. The machine can recalibrate difference, but often doesn't eradicate or move past the paradigm. Whatever techniques Bel uses to baffle and neutralize, still retain properties made common by the proscenium frame. But Agamben offers the challenge that Bel takes up – to evince a structure that offers a shift or opening for a weak messianic proposition – a present movement toward an un-forclosed and always deferred futurity that finds different modes of social beings becoming indistinct through the repeated attempts and partial successes of disordering theater's dispositifs. Without that movement, and without the weak messianic impulse of any theater director or choreographer, there would be no grappling with forms of creation and abandonment that shifts theater's will to produce and reiterate hierarchies of relations and social and political subjects.

Thinking and feeling from the paralysis that overcame me during Damien Bright's response to Bel, in this essay I am trying to read *Disabled Theater* as a trisomic encounter or stage. It is an entanglement and a minute shift in the codes or the genetics of theater that might neutralize theater's exemplary capacity to performatively produce social subjects. A trisomic engagement succumbs to the theatrical lure and it baffles. Bel achieves that state by deploying the intensities of theatrical isomorphism. A trisomic entanglement also allows the historical racial, gendered, ethnic and ableist fantasies to irrupt like the logic of a joke, that arise not from the stage but from within the spectator. For me, the question then becomes what the trisomic encounter can do to all parties who allow themselves the experience of that produce different consequences for all entangled in the trap – in this case – of the discursive category of disability and the implications of abandoning the avant-garde's continual interrogation of forms.

An immersive engagement with the trisomic stage allows for flashpoints to emerge and expose the codes that maintain the paradigm's productivity. And a trisomic entanglement dislodges the formal gestures that allow disability to cohere together. Like that bad penny that keeps turning up, there are so many framing devices that insist on the positive property common to performers. From the vantagepoint of the trisomic I can understand Koppers dismissal of *Disabled Theater* in TDR as "being cued to boredom" (35). This framing calls up the histories of pronouncing onstage subjects who isomorphically appear close in performance to performing themselves as subjects of a historically stigmatizing category as "tired" and dismissing the attention to form as an elitist and therefore undemocratic property belonging to an the avant-garde and (or) paradoxically of low aesthetic value. But really, it comes from *A Chorus Line*, a popular work whose formal intervention had some of the most far-reaching effects on the evacuation of how the modern theatrical economy depended on the fantasy of the single author or director as the lone genius. The production and all of its collateral cultural products and productions also undermined the economic hierarchies of payment to principles and chorus members (although it didn't revolutionize or equalize the disparity of pay for different categories of artists).

And in the unapologetic structure of her formal critique, Koppers' avoidance of the scene of entanglement echoes the reactionary and socially damaging position of dance critic Arlene Croce who in 1994 declined to review Bill T. Jones' production of *Still/Here* because of its over determination

for Jones placed bodies onstage that Croce articulated as uber-potent surrogates of illness. Koppers writes that she has put “victim art” past her – but she repeats Croce’s act. And that act has its many historical precedents as well having overdetermined all that critique around overdetermined embodied materiality that has succeeded it. But Croce’s refusal is linked as a critique of the normative strategy of theater criticism circa 1974 by New York Magazine’s theater critic, John Simon, who quite violently dismissed Robert Wilson’s production of *A Letter To Queen Victoria* specifically because of his avant-garde enrapturement with categorical indeterminacy. Simon attended Wilson’s piece, but like Koppers and Croce, was stubbornly unwilling to become captivated or consider the potential of a trisomic stage (apparently unlike queer choreographer Jerome Robbins) precisely because disparate aesthetic categories, forms and histories were becoming indistinct and entangled. Simon also presaged the link between queer and categorical refusal. Simon wrote:

Though the work calls itself an opera, it is merely tableaux vivants done to monotonous nonmusic and accompanied by meaningless verbalizing and gyrations. The visuals are derived principally from Chirico, Magritte, and (except they are nowhere so heterosexual) Delvaux, and the words are Dada, but with the wit left out. That such things should succeed in the world that has lost all sense of what is art (to say nothing of all sense of what is sense) is not astonishing. But what is queer is that people who should know better, e.g. Jerome Robbins, should invoke the word genius for his mindless farrago. (John Simon on theater, 44)

What Simon really hates, and has no problems suppressing, is the use of Christopher Knowles by Wilson who “knows better.” What irks him is how Wilson succumbs to be captivated anyway and in fact, resorts to an isomorphic structure that imitates Knowles’ modes of embodiment. The sharing of credit regarding authorship offers cultural capital to Knowles to be sure, but it also acknowledges the indeterminacy of authorship that always exists in the making of forms and knowledge collaboratively.

What is truly pitiful though is that a fifteen-year old autistic boy should be a kind of co-author and main performer here, his sad condition put on tasteless display. Wilson has worked with handicapped children and his writing and cast may themselves be specimens of a dementedly self-induced autism, but all that does not justify having the poor boy whirl about like a deranged dervish and spout insensate and ill-articulated verbiage – even if Wilson

proclaims it genius and matches it with similar cavortings and a cacophony of his own. Unless we bring back bearbaiting and visits to the asylum for entertainment, this sort of thing, however cloaked in euphemism is not to be countenanced. I am also leery of Wilson's making his grandmother, aged 88, stay up late and fatiguingly in order to perform in this and other Wilson works: it is one thing to give one's life for art, another for autism. (44-45)

Simon's offhanded grandmother comment is also not at all tangential or extraneous – it is in fact central to the positioning of submission and captivity as a posture that can baffle hierarchal assumptions. There is no indication that Wilson's grandmother was "made" to do anything – that she could not consent to the conditions of her aesthetic labor. Indeed, who even knows if she did not initiate or ask to be included so to elevated her visibility, enable her to perform creative labor at a time when many women her age are confined to the home or an institution and whose inclusion staged a genetic and genealogical link. Read alongside Bel's embrace of neurodivergence but the disappearance of Hossle and Meier, it calls up what is still inadmissible in this isomorphic lure – aging female bodies whose aesthetic physical presentation in performance conjoins and expresses sexuality, affective unruliness and a resistance to the social effects of aging.

So much of this critique and the aporia that is not an aporia of *Disabled Theater* rests on anxieties of consent, which also become more hypervisible when isomorphism in the theater is hyper-intensified and the knots and entanglements between the subject and the subject as actor, playing herself onstage are tightened. Simon's critique of Wilson's grandmother's state doesn't accommodate for how the baroque stare might accommodate for differentiated ability and risk. The evening I saw Damian Bright dance in Milan, he seemed overcome and Chris Weinheimer, the onstage translator and stage manager who also serves as a proxy for Bel escorted him offstage. Bright later reappeared and nothing else was made of this incident. The isomorphic structure Bel formulates is flexible enough to allow for these lines of flight and recapture. In the trisomic stage, the spectator is immobilized but party to all the codes so that s/he can accept this partiality, and can recognize the necessity of the exit and disappearance. In TDR, Kupperts lauds the production of *Ganesh Versus the Third Reich* by Back to Back Theater at the expense of the more indeterminate *Disabled Theater* for its more definable structure which she posits as more pleasurable precisely because that work is far more recognizable as a play within a play with distinct qualitative differences rather than an isomorphic structure. As such it diminishes the

realm of the trisomic where the viewer consciously is overloaded in the work of discriminating, sorting valuing element. As such, although her intent is to celebrate and expand the notion of disability culture, the mode of her critique follows the dismissive logic of Croce and Simon and is a reharroing of old ground, dependent on the valuation of binary logic.

Clearly Bel with Theater Hora doesn't or cannot recalibrate *all* of the hierarchies of theater that control the frame. But, like Borges *Library of Babel* or *A Chorus Line's* wall of mirrors, when failure or success is exposed, more hierarchies irrupt and proliferate from which the incapacitated spectator can succumb to the captive position in order to comprehend the mechanisms of paradigms. Bel, following Barthes, cannot achieve "theater degree zero." although he tries to disable the harrow. Thinking with Barthes, Bel experiments with a mode of theater that casts a trap baited by his use of overdetermined material. In this instance and what seems like the limit case for theater, the bait and lure is embodied and enacted neurodivergence. The category is itself a wildly unstable fantasy and when a professional actor who places her body onstage to be read through that discursive lens, the best result is that all parties involved might meet the situation with a "baroque stare." The pioneer in the field of disability studies, Rosemary Garland Thompson best described this mode of looking as one that "bears witness to a failure of intelligibility... [it is] an overly intense engagement with looking. A baroque stare is unrepentant abandonment to the unruly, to that which refuses to conform to the dominant order of knowledge. As such, baroque-ness resides not in the visual object but rather in the encounter between starrer and staree. Baroque staring entangles the viewer and viewed in an urgent exchange that redefines both" (50).

Proliferating codes outside of the theater, writing or performance cannot be captured and can never be calibrated precisely enough or in exponential quantities to neutralize stigmatizing systems of valuation. In fact, however brilliantly Bel renders the stage as a coded information exchange system and how much we bring to it to easily suspend our disbelief that the theater can extricate us from the tyranny of the paradigm the audience begins to realize that Bel's choices are only the low fruit on the ever-proliferating tree. What is more exciting about the proposition are the possibilities it offers – an alternate way of experiencing the trisomic where spectatorship and performing risks entanglements that allow for fugitivity and flight, captivation and capture, bafflement and paralysis.

References

- AGAMBEN, Giorgio. *The Coming Community*. Minneapolis: University Minnesota Press, 1993. Print.
- BARTHES, Roland. *The Neutral: Lecture Course at the College de France (1977-1978)*. Columbia University Press, 2005. Print.
- CHOW, Rey. *Entanglements, or Transmedial Thinking about Capture*. Duke University Press, 2012. Print.
- GARLAND-THOMSON, Rosemarie. *Staring: How We Look*. Oxford University Press USA, 2009. Print.
- Hilton, Leon. "Presence, Rhetoric, Difference: Jérôme Bel and Theater HORA's Disabled Theater." *TDR: The Drama Review* 58.3 (2014): 156–162. Print. "Jérôme Bel Talks about Disabled Theater." *Time Out New York*. N.p., n.d. Web. 11 Nov. 2014.
- Jowitt, Deborah. *Time and the Dancing Image*. University of California Press, 1989. Print.
- Kuppers, Petra. "Outsider Histories, Insider Artists, Cross-Cultural Ensembles: Visiting with Disability Presences in Contemporary Art Environments." *TDR: The Drama Review* 58.2 (2014): 33–50. Print.
- MITCHELL, David T., and SNYDER, Sharon L. *Narrative Prosthesis: Disability and the Dependencies of Discourse*. University of Michigan Press, 2000. Print.
- ORTEGA, Francisco. "The Cerebral Subject and the Challenge of Neurodiversity." *BioSocieties* (2009), 4, 425–445.
- RUBIN, Gayle. "Thinking Sex: Notes for a Radical Theory of the Politics of Sexuality." In Carole Vance, ed., *Pleasure and Danger: Exploring Female Sexuality*. Pandora Press, 1993.
- SCHMITT, Natalie Crohn. *Actors and Onlookers: Theater and Twentieth-Century Scientific Views of Nature*. Northwestern University Press, 1990. Print.
- SIMON, John Ivan. *John Simon on Theater: Criticism, 1974-2003*. Applause Theater & Cinema Books, 2005. Print.

DEBRA LEVINE is an Assistant Professor of Theater at NYU Abu Dhabi, affiliated faculty at NYU Tisch Department of Drama, and also affiliated faculty with the Hemispheric Institute of Politics and Performance. Debra's 2012 dissertation, "Enduring ACT UP: the Ethics, Politics and Performances of Affinity", explores how within the AIDS Coalition to Unleash Power (ACT UP), forms of collective civil disobedience gave rise to new paradigms of caretaking for activists with HIV and AIDS. Debra has published reviews and articles in *Theater Research International*, *GLQ*, *Women & Performance*, *e-misferica*, and *the Disability Studies Quarterly*. She holds an MFA from Columbia University, has directed extensively for the theater, and produced a number of independent documentaries including three about AIDS in incarcerated populations in New York State and Oklahoma.

*“Why won’t you help me ... shave my head?”
Critical autoethnography and understanding affective
response to an act of critical vulnerability in solo performance*

LAURELANN PORTER*

Abstract: In my current arts-based research practice, I explore the aesthetics of critical vulnerability as it relates to my solo performance “How not to Make Love to a Woman,” a critical autoethnography and solo performance piece about leaving an abusive marriage. The initial research question revolved around an examination of how aesthetic choices contribute to affective responses. As the performance and the research both transformed, I became less interested in aesthetic choices and more about descriptive accounts of what occurs between spectator and performer in the moment of critical intimacy where the audience is invited to shave the performer’s head. Through this examination I have come to understand some of the ways the affective spectator responses to these moments of spectator-performer interactions can result in the kinds of subtle attitudinal shifts that contribute to increased possibilities for community dialogue about the subject of domestic violence.

Keywords: autoethnography, solo performance, vulnerability, domestic violence, affect, performativity

Introduction

As I prepared this piece for its various locations, I developed objectives rooted in my interpretation of Susan Sontag’s call for an “erotics of performance.” She suggest, in her essay “Against Interpretation” that an erotics (rather than an hermeneutics) of performance should be theorized as a step toward reducing the emphasis on intellectual interpretations of art in order to open up modes of discussing artistic practices that might incorporate an awareness of the ways affective responses help to determine our understanding of art

* Independent playwright and performer, PhD in Theatre and Performing Arts at Arizona University, e-mail: laurelannporter@gmail.com

and performance. She calls for alternative ways of engaging with art that call upon epistemologies not linked to the Cartesian split of mind and body. She urges the reader to find ways for descriptive methods, rather than prescriptive methods, to be incorporated into a possible erotics of art.

Using descriptive methods of audience responses as the methodological basis for inquiry has been a challenge when trying to provide quantitative results. The percentage of audience members who have offered responses either in post-show discussions or in surveys has been relatively small. However, following the logic of sociologist Boaventura de Sousa Santos' epistemologies of the Global South, I posit that quantitatively-driven studies around this particular topic might, in addition to being unfeasible, negate the value of individual responses to theatre that has the potential for sparking productive dialogue about difficult topics such as the topic of my performance piece. In his essay, de Sousa Santos reminds scholars that a privileging of the logic of the dominant scale, which assumes that quantitatively measurable results matter more than subtle results, can risk losing sight of more nuanced analyses and the potential for subtle shifts to be considered of value.

For the purposes of this study, I will be privileging audience responses as expressed in terms of emotional, somatic or affective responses. This includes descriptions of visceral responses, responses that tap into an individual's previous emotional history, descriptions of emotions or sensations experienced during the performance, and post-show reflections that examine or explore the ways a person's intellectual response was shaped by the felt experience of being in the audience.

I distinguish this solo performance from other work (including some of my previous solo performances) by a few important definitions. Ethnography, broadly defined means the writing of culture. It follows that autoethnography consists of the writing of one's own culture. I distinguish this from autobiography in the sense that culture consists of built, shared and assumed narratives. The process requires not merely the telling of one story, but a look at the way stories have patterns and an underlying logic to them. Autoethnography, therefore, is the examination of the narratives that have built the way I understand myself and my culture. Critical autoethnography demands that the scholar pose questions of these narratives in order to come to a deeper understanding of how and why those narratives have shaped the lived experience. In practice, autoethnography should result in new insights or disruptions about assumed causal relationships between key events in a person's life. For me, this resulted in new insights and disruptions about how I ended up in an abusive marriage.

Pre-Show Voiceover excerpt #1

I was raised to believe that sex was a temptation of the devil and that unless it occurred within the confines of marriage it was evil. But I wasn't born with that opinion. One of the experiences that happened to me as a child was the experience I had with a neighbor. He was always happy to allow the neighbor kids to play in his yard. And we all did. We climbed trees, roller skated, and just generally ran around doing what little neighborhood kids do, I suppose. And once in a while, he would ask if I wanted to rest and sit on his lap. I did. I always liked sitting on laps when I was a kid. When I was very young I would sit on my mother's lap and try to synchronize our breathing. It was like a meditation and it felt calming, very peaceful. He would let me sit on his lap, right there in his driveway, in front of everyone, in plain sight. And he would situate himself in such a way that he could put his hand in my crotch without being seen by anyone. He would ask me if I wanted him to “tickle” me. I said OK. And he would put his hand in my panties and fondle my little girl labia. But here's the thing. I actually enjoyed it. I enjoyed having my labia touched. The tickling sensation was actually quite pleasing. He was very gentle and I thought it was a fun little secret. (Even though I don't ever remember him saying to me what we were doing needed to be kept a secret.) I wondered why he felt he had to offer me candy afterward. I liked his touch a lot better than the candy. So you can imagine how confused I was when, after telling my best friend, and after that best friend told her mom, that he denied everything when he was confronted. I wasn't mad at him. I was mad at my friend for betraying my secret. I remember being so confused at why my friend's mother was so mad at him and why he was so adamant that it didn't happen. I hated being called a liar.

The development process

“How not to Make Love to a Woman” was developed as part of an ongoing effort to address issues of domestic violence in the world around me. The piece was developed as a way to grapple with questions I had regarding my failed marriage. I was eager to understand how I found myself in a situation of abuse, an emotional space I never imagined I would occupy. The performance was originally envisioned as a darkly comic piece of stand-up comedy. An early workshop production resulted in some audience members commenting “I didn't know if I was supposed to laugh or cry.”

Around the same time I was developing this piece, I was also working on a documentary film about the lives of women who have also recovered, or are still recovering, from domestic abuse. Segments of the performance piece were included in the film to offer creative and dynamic counterpoints to the stark and emotionally bare stories of the women interviewed. This film was further workshopped in a graduate seminar on visual ethnography where difficult questions about the ethics of presenting these stories together were posed. Some colleagues commented that the creative approach of my solo performance undermined the stories of the women interviewed. Others commented that the women interviewed were exposing themselves in a way that leaves them vulnerable. I left the seminar feeling that I needed to pose deeper questions to myself about this piece and this process before I could consider the process complete.

I brought the solo performance piece into a workshop on critical and postcolonial autoethnography and began a process of unpacking the creative piece I had written to determine answers to the following questions: "Is this ethnography? Is this critical? If so, what makes it so? And what does it do as such?" What resulted was a series of critical reflections that questioned the ways my own life experience resulted in repeated patterns and narratives. This helped me understand a little more about the questions I posed ten years prior with the original piece of stand-up comedy. I say "understand" not in the sense that I found answers, but in the sense that I exposed deeper questions I had ignored most of my life.

This process involved digging into my own assumptions and narratives to expose vulnerabilities in myself. These vulnerabilities I then staged as a "critical vulnerabilities."¹ But the crucial part of this is exposing these vulnerabilities for a directed purpose. It is not enough to claim vulnerability as part of some self-congratulatory egocentric need for attention and sympathy. In fact, I question those motives harshly. That kind of self-indulgence will most likely result in alienating the audience most in need of engaging with the material. My autoethnography is a process that reduces the emphasis on merely telling my story, but emphasizes the need to reflect on my story and question it in order to gain new insights. I felt the need to understand through performance

¹ I first heard this term in a call for proposals for a special journal issue on "Risky Aesthetics" in which performed vulnerability elicits some kind of attitudinal shift. I later learned the term is used in military discourse to describe the opportunities in which an enemy might have spaces that, if penetrated, would result in certain victory for the attacker. The tension between these two meanings can be productive if we consider the very real possibilities implied in true vulnerability.

the ways vulnerability engages the potential for dynamic interchange between performer and spectator. I deliberately proposed a performed critical vulnerability intended to elicit an affective response in the spectators.

I felt strongly that, if I were to perform this piece for audiences that might include people who had survived domestic abuse (and statistically, this is almost guaranteed in any room with an audience of more than a dozen people), then I needed to expose myself and leave myself vulnerable in a way that allowed spectators to recognize and appreciate their own vulnerabilities. In order to stimulate a healthy dialogue among and between individual audience members, I felt it was important for them to see and feel in a visceral, somatic mode, that another human being before them was willingly placing herself in a precarious position. My proposal is that my story alone is not enough to create that spark which can result in productive dialogue. The vulnerability needs to be felt.

Pre-Show Voiceover Excerpt #2

The socialization of sexuality by way of scare tactics seems to be at the root of so many forms of suffering, be they insecurities about one's own place in the world or a fear that what is natural and normal is a dirty, evil, sin. Now I look back and I see how it can be construed that what my neighbor did was wrong because an adult with power over a child should never abuse that power. But I don't ever remember feeling like he had control over me, or authority, or power. I remember feeling like it was absolutely my choice to sit on his lap or not. I am troubled when I try to view that act in terms of whether it was "abuse" or not. When children do those things to each other we say they are "playing doctor" and laugh it off as normal/ natural curiosity and exploration. But at what age is the dividing line between normal/natural curiosity and an abuse of power dynamics?

I thought of that incident later in life. I was confused and refused to admit that it had anything to do with my current relationship to intimacy. I insisted that I had not felt traumatized by the incident. And I felt as if my close friends were asking me to invent a trauma so I could feel victimized and subsequently recover. I felt very much like my situation was different, that if I never felt trauma then I should not be forced to feel traumatized by the event. I still feel this way. And perhaps that means I still have something to learn. Freud would have a field day with me, would he not? But I also believe that social forces ask us far too often to feel victimized. I would rather find the ways I can allow myself to feel empowered rather than feel victimized.

The Opening Moments

The main act of critical vulnerability occurs when the onscreen directions ask for audience volunteers to shave my head in order for the rest of the performance to continue. As the performance space opens, spectators enter to see a nude female body (mine) on the ground with the words “shame,” “guilt,” “victim,” and “survivor” written across her body. This image is contrasted with a light-hearted musical soundtrack and a somewhat sardonic voiceover speaking of a series of incidents in my past that may have contributed to the result that I found myself in the position of victim. In the middle of these stories told over the soundtrack, words projected onscreen counter the narratives with critical questions and demand that the audience help me shave my head. For me, as the performer, this head-shaving is a necessary ritual for cleansing and healing. For many audience members, participating in this head-shaving felt like they were continuing the violation of the prostrate female body. The audience becomes implicated in a complex series of questions about what to do when faced with parallel circumstances in life.

What I learned later, after viewing footage of one performance and speaking with audience members after another one, is that people who did not know me were unwilling to perform the very act I was asking them to perform upon me, even though I insisted I needed my head to be shaved in order to continue with the performance. Only people who were acquainted with me and my personal style and the fact that I love having my head shaved were willing to engage in this act. I knew this might be a potential challenge with the performance so in all cases I had a plan on hand to begin the process if no one from the audience offered to begin the task.

Some audience members told me they felt it reinscribed histories of oppression wherein female bodies are violated, as in the case with Jewish women in Nazi Germany who had degrading words written on their naked bodies before their heads were shaved. Others expressed a desire to understand how constructed notions of female beauty were linked to hair and whether or not the performed act was in an attempt to disrupt or reject those notions. One of my collaborators, in preparation for the performance in Brazil asked “don’t you think you are implicating the audience with this gesture?” Yes, as a matter of fact I am. In this community, as in many others, domestic violence and violence against women are taboo topics. A direct and overt approach to dialogue often results in literal and proverbial doors slamming in one’s face. I believe that this critical vulnerability can offer smaller, more palatable entries into dialogue for this topic, which has proven to be so difficult to approach.

In addition to this staged moment of vulnerability, I have also developed an aesthetic that supports this performative act. I have trained with some incredibly virtuosic performers in my life, from the members of the double edge theatre in Massachusetts to members of the Odin Teatret in Denmark. I have a deep respect for the intensity and dedication that these artists have shown as both performers and as teachers. However, I have come to the realization that for my purposes in this particular performance piece, a slightly “rough around the edges” aesthetic becomes important for connection with the audience.

My intention is to encourage audience members who may have some personal connections to this work to sense from the opening moment of critical vulnerability that there is a space opened that allows for mutual vulnerabilities to be recognized. I do not wish to equate my experience with the experiences of others who may have been deeply traumatized by sexual abuse or domestic violence. However, I do believe that an individual audience member, at whatever point on his or her journey s/he might be, will have a more positive response to the show if they can recognize, in a way that is felt as a somatic response, that a person with vulnerabilities and imperfections can still find personal joy, success, or transformation.

The Four Settings

I will now examine the responses from four distinct groups of spectators and how the work of the piece can be shaped for future performances based on the responses received in these four settings. The first setting was an invited dress rehearsal performed for graduate faculty and fellow doctoral students of performance wherein the head shaving was simulated by an act of hair brushing. The second setting was the performance at an academic conference performed in an intimate setting, seating only about 15 spectators, made up largely of theatre scholars. The third setting was in a community center in a small town in rural Bahia, Brazil. The fourth setting was a performance at the Phoenix Hostel and Cultural Center in Phoenix, AZ. I will describe the ways data was collected, compare the responses, and propose possibilities for continuing the research with future performance opportunities.

After the dress rehearsal at Arizona State University in November of 2013, fellow colleagues consisting of faculty and PhD students offered some critical insights. At one point an audience member suggested that perhaps I had elicited something I did not want to elicit during the opening head-shaving scene. She indicated that if she were presented with a nude female body and

was prompted to shave her head, she would not be willing to do so because the act would feel like a reinscription of violence against women. She felt like the substitute action of hair brushing felt more compassionate.

This points to an interesting aspect to remember when engaging in work that has the potential to elicit responses that might trigger past traumas in the audience members. The audience will have no way of knowing that I personally enjoy having my head shaved unless I indicate this to them. Furthermore, even though I added verbal information in the piece to indicate that I enjoy this, audiences in subsequent performance were still reluctant to do so. This seems to indicate that individual spectators' personal affective responses to the work will weigh more heavily than verbal instructions from the performer.

During the post-show discussion at the performance for the American Society of Theatre Research conference in Dallas, TX in November 2013, audiences had similar reactions. At this point I had not yet changed the pre-show voiceover and video montage to reflect my opinion that I enjoy having my head shaved. I was interested in testing the reactions of others to confirm whether or not this was a limited opinion or if several others had similar responses. I was particularly interested in testing this with an audience that actually physically engaged in the head-shaving. The Dallas audience confirmed what the colleague in dress rehearsal commented: that they felt like the head-shaving moment was an act of continued violence against a female body already literally inscribed with the written words "victim," "guilt," "shame," and "survivor" on her body. One person suggested I write other words on my body that were more positive. Another person suggested I indicate somehow to the audience that I actually enjoy having my head shaved and that I find it to be cleansing and empowering. Still another person associated the head-shaving moment with a provocative commentary on the socially constructed nature of feminine beauty. This might be true, but I consider that to be tangential to the main purpose of the project.

During the performance in Itacaré, Bahia, Brazil I faced an interesting challenge. The "plant" that I had selected for this performance encountered a difficulty. For this show, the site of the performance was a community center where two of the four walls were constructed from wooden posts where people outside could peek through the holes to see what was happening in the performance space. The community leaders had decided that we should not open to the show to children under 11 years old. Perhaps because of this prohibition, some of the children in the community became curious and were peeking through the holes in the wall to see what it was that they were not permitted to see. They might have been particularly curious to see what their "professora de teatro" was doing that was prohibited for them to see.

The person I had selected as a head-shaving plant saw this happening and went outside to chase off the children who had transgressed this boundary that was given them. As the soundtrack to the pre-show reached the point where I knew shaving needed to begin if I were to finish before I started the official performance, I was in a quandary. In a way, I became distressed at the possibility that no one would come forth. Perhaps this was occurring at the same time audience members were sensing a kind of inverse anxiety at the possibility of being asked to come forward and shave the performer's head. My response was to sit up, grab the clippers and slowly turn around to face the audience, wordlessly imploring someone, anyone, to help me shave my head. After a moment of tension, a woman I knew from my fieldwork interviews came forward and began the process. I closed my eyes again and allowed the moment to continue.

When I later looked at the footage from this performance I realized that only people with whom I had had some personal contact prior to the performance came forth to help with the head-shaving. This indicates that, to some degree, audience members who are strangers to me are not willing to engage in this kind of intimate exchange with the performer. However, it also opens up the possibility for another way of looking at this kind of performative exchange. The audience members who already know me, who already have a certain degree of intimacy with me, came forward and participated in the performance in this request for interaction. They were willing to co-perform this staged moment with me. This allows for those who don't know me to be witnesses or observers to the moment even if they do not feel comfortable contributing to the head-shaving moment.

During the performance at the Phoenix Hostel and Cultural Center in May of 2015 something different happened. The person I had selected to be the plant did not come forward to begin shaving my head. My partner, who was the videographer for that performance, sensed that something was wrong when he realized no one was coming forward. He walked over to a mutual friend and asked her to start the head-shaving because "no one else had the balls to do it." Because my eyes were closed, I did not see who began the head-shaving. What I did sense, was a particular sensitivity she had as she shaved me. I remember thinking "Oh, this person is being really gentle. I bet she thinks she might hurt me." After a few minutes of this I felt another person take over. This person shaved my head with a confident touch, but gentle enough that I was comfortable the entire time.

I found out later it was my own partner who had observed that our friend was being too gentle and the task would not be adequately completed unless someone stepped in who knew how to quickly and efficiently shave someone's head. He stepped in since he has shaved my head many times before and felt he

could ensure I reached a good point before the pre-show voiceover ended and the show had to continue. I also found out later from two other audience members that they felt nervous watching my head get shaved, afraid I would be hurt somehow, but as soon as they saw my partner step in they were more comfortable. One woman even said she was pleased to see a side of my partner she hadn't seen before, a kind of gentle compassion with which he performed the act.

Critical Vulnerability and Audience Response

I should point out that never once during any of these performances did I ever feel that a person shaving my head was being too aggressive or too rough. Even those with a firmer touch were still within a range in which I felt comfortable. I do recognize, however, that the risk is there for someone with ill intentions to hurt me, either with a rough touch of the clippers, or being in such close proximity to my naked body. In fact, after the Phoenix performance one audience member commented that the people who "really need to see this piece" are the kinds of men who congregate at sports bars downtown. He even suggested I stage this in a setting where I could bus a group of men from a local sports bar to the performance in order to see the piece. I have to admit I was not comfortable with this idea at all. The prospect of performing this show, particularly the opening scene, for a group of potentially drunk men gave me pause to consider the limits of my own proposed critical vulnerability. I am willing to place myself in a position of vulnerability as long as I have some systems in place to make me feel ultimately safe from harm.

However, my interests in exploring the act of performed critical vulnerability stem less from pushing my own boundaries and more with exploring the ways this critical vulnerability elicits particular responses in the audience in ways that might spark a shift in attitude or perception in order to prompt productive dialogue about this subject, which has proven so difficult to approach in many communities. What I have realized is that my own measure of vulnerability and each individual audience member's measure of what constitutes a vulnerable act might be drastically different. This also implies that the degree to which an audience member feels he or she is witnessing an act of vulnerability will influence his or her affective response. This in turn, affects the degree to which an attitudinal shift might occur. Additionally, initial findings have indicated that the degree to which a person had similar life experiences also contributed significantly to his or her openness to this kind of shift in perspective.

One audience member from Itacaré commented that the ludic manner with which I approached the topic, with no bitterness or aggression, allowed

her to remember a similar childhood incident in a way that did not provoke residual trauma. She admitted that she, too, felt a moment of relief and release in recognizing that the event in her childhood, which could have been construed as traumatic, was in fact to a certain degree enjoyable for her as she remembered it. She felt the performance allowed mental space for this kind of relief and release of past events. Another audience member in Itacaré who has openly admitted to witnessing domestic violence as a child and being subjected to emotional abuse in her marriage, indicated that this piece provided an invitation to dialogue in her community that had been previously difficult to approach.

One audience member from the Dallas performance indicated that the performance brings up important questions about how to teach consent to children. Another Dallas spectator commented that we teach kids how to eat healthy, but we don't teach them how "to pleasure healthy." So, while the performance does not provide possible solutions to these social dilemmas, the spark to dialogue is a step in the right direction. Another Dallas audience member indicated that the tension between the perceived "confident performer" and the opening moments where the images hint at the weakness of being a victim provided a space of potential. This space offered the possibility for others who might have experienced similar violence to imagine future confidence where histories of violence, which might have prevented them from imagining a confident self previously, could be reduced or diminished.

One woman at the Phoenix performance expressed to me that watching the performance provided her with a level of self-forgiveness she had not previously imagined for herself. Another woman from the Phoenix performance indicated that the demonstrated transformation from vulnerable victim to empowered independent woman provided a model for other women who might have experienced similar traumas. Another woman from the Phoenix performance indicated that, while the rest of the performance was entertaining and enjoyable, it was the opening moments that truly spoke to her on a visceral level, to a degree that it stayed with her for days. I believe that is in these visceral responses to the opening moments that the shift in attitude or perception can plant seeds for the personal transformation of the audience.

References

- AHMED, Sara. *The Cultural Politics of Emotion*. New York: Routledge, 2004. Print.
-*Queer Phenomenology: Orientations, Objects, Others*. Durham: Duke UP, 2006. Kindle.
-*The Vulnerable Observer: Anthropology That Breaks Your Heart*. Boston: Beacon Press, 1996. Print.

- BEHAR, Ruth and Deborah A. Gordon, eds. *Women Writing Culture*. Berkeley, UC Press, 1995. Print.
- BOWLES, Norma and Daniel-Raymond Nadon, Eds. *Staging Social Justice: Collaborating to Create Activist Theatre*. Carbondale: Southern Illinois UP, 2013. Kindle.
- CARLSON, Marvin. *Performance: a Critical Introduction*. 1996. 2nd Ed. New York: Routledge, 2004. Print.
- CONQUERGOOD, Dwight. *Cultural Struggles: Performance, Ethnography, Praxis*. Ed. E. Patrick Johnson. Ann Arbor: U Michigan Press, 2013. Print.
- DANIEL, Yvonne. *Dancing Wisdom: Embodied Knowledge in Haitian Vodou, Cuban Yoruba, and Bahian Candomblé*. Urbana: U of Illinois P, 2005.
- The History of Sexuality: An Introduction: Volume 1*. 1976. Trans. Robert Hurley. 1978. New York: Random House, 1990. Print.
- The Use of Pleasure: Volume 2 of the History of Sexuality*. 1984. Trans. Robert Hurley. New York: Random House, 1985. Kindle.
- FREIRE, Paulo. *Pedagogy of the Oppressed, 30th Anniversary Edition*. 1975 Trans. Ramos, Myra Bergman. New York: Continuum, 2005. Print.
- GOFFMAN, Erving. *The Presentation of Self in Everyday Life*. Edinburgh: U of Edinburgh Social Sciences Research Center, 1956.
- Frame Analysis: An Essay on the Organization of Experience*. 1974. Boston: Northeastern U Press, 1986. Web.
- GOLDSTEIN, Sarah. "PSi conference challenges audience's level of comfort." *Brown Daily Herald*. [Providence, RI] 5 April 2005: np. Web.
- HAUTZINGER, Sarah J. *Violence in the City of Women: Police and Batterers in Bahia, Brazil*. Berkeley: UC Press, 2007. Print.
- HELGUERA, Pablo. *Education for Socially Engaged Art: A Materials and Techniques Handbook*. New York: Jorge Pinto Books, 2011.
- LEAVY, Patricia. *Method Meets Art: Art-Based Research Practice*. New York: Guilford Press, 2009. Print.
- MARTINEZ, Jacqueline M. *Communicative Sexualities: A Communicology of Sexual Experience*. Lanham: Lexington Books, 2011. Kindle.
- SEDGWICK, Eve Kosofsky. *Touching Feeling: Affect, Pedagogy, Performativity*. Durham: Duke UP, 2003. Kindle.
- SONTAG, Susan. *Regarding the Pain of Others*. New York: Picador, 2003. Print.
- TURNER, Victor. *From Ritual to Theatre: The Human Seriousness of Play*. New York: PAJ Publications, 1982. Print.

LAURELANN PORTER received her PhD in Theatre and Performance of the Americas from Arizona State University. She is also a playwright and performer. As part of her research she performed her solo performance "How not to Make Love to a Woman" ("Como Não Fazer Amor com uma Mulher" in Portuguese) in order to understand how performance can contribute to public dialogue about difficult topics. Laurelann received her BFA in Independent Theatre Studies from Boston University and her MFA in Playwriting from Arizona State University. She has directed and produced several short films, music videos, and two feature length documentary films.

Shame. Spectatorship Strategies in Historical Documentary Theatre

IULIA POPOVICI*

Abstract: Taking as examples two recent theatre performances that use documentary techniques in order to deal with subjects of recent history (the largely ignored Holocaust in Bessarabia under Romanian ruling and the surveillance of private citizens, by the secret police, in Romania in the eighties), this article explores the strategies that documentary theatre employs for eliciting certain emotions among their audience. The approach takes into consideration the theories of the sociology of emotions and the theatre literature about the emotional effects of direct address in non-participatory performances, in order to develop a demonstration that for the performances given as examples, shaming/spectatorial shame response is a theatrical strategy actively chosen for its potential to overpass the conventional passiveness of the audience.

Keywords: documentary theatre, social emotions, empathy, shame, active spectatorship

What is the *outcome* of a theatrical experience, for the audience – in terms of intellectual projection more than empirical facts (hard or even impossible to get, taking into consideration the specific nature of theatre spectatorship)? Might artists actually anticipate, “programme” a certain kind of reaction, playing with spectatorial conventions and theatrical strategies, in order to trigger responses that go beyond the simple range of individual emotions associated with theatre experience?

What makes theatre special in terms of the impossibility to genuinely talk about spectatorship and the effects/outcomes of performances on the audience is its dual nature – as an extremely personal experience and a shared, collective one, provoking the individual spectator to negotiate his/her responses to those of the others (Grehan, 2009, 4) and to the audience group as a temporary, ad-hoc community. There are so many factors that play a role in

* PhD candidate at University of Arts Targu-Mures, e-mail: iuliapopovici@gmail.com

individual responses – from the cultural context to personal experiences – that a certain efficiency of theatre, even when it actively seeks one (as it happens in engaged/political or community-based performances), is extremely difficult to measure and follow.

The psychological reaction (which qualifies for the purpose of this analysis, as we would see, as a social emotion) most often associated with theatre is empathy. Empathy is the most talked and written about emotional relationship generated between what happens on stage and those who watch the staged events – starting, of course, with Aristotle, and culminating with Brecht's aversion against the "emotional orgies" meant to free the spectators of their social guilt. While preserving some of the elements still considered today as defining for the affect/emotion of empathy – to feel/non-cognitively understand other persons' feelings, to share or respond to other people's emotional state, to make less distinctive the differences between the self and the others (parallel emotion, reactive emotion, empathic concern, personal distress – Davis, 2006) –, Aristotle's empathy is limited by his perspective on it as being *passive*. For the *Poetics'* author, empathy generates pity, for the tragic characters, and fear, for the consequences of acting, in real life, the same way as the characters (these two would be, in a modern interpretation, the outcomes of empathy) – both preventing the spectator to take social and political action.

The centuries passed by since Aristotle wrote about empathy and the immense body of theoretical writings and artistic practices focused on the spectator as an active player in the dynamics of theatre and social reality haven't totally displaced the passiveness induced in the audience through the theatre spectatorial dispositive. Mainstream contemporary theatrical conventions, highly influenced, as Nicholas Ridout notices (Ridout, 2006: 71), by the focus of the modern(ist), late-19th, early-20th century theatre on realism and naturalism, imply that the play on stage is a self-sufficient autonomous world emulating a different life – both the fourth wall and the Stanislavskian acting working towards this model and preventing the spectators from expanding the range of their emotions.

In his study on empathy (Davis, 2006, 450 and *passim*), Mark H. Davis designs a model of this social emotion as a "set of constructs that connects the responses of one individual to the experiences of another", according to which the interpersonal outcomes of empathy are "helping, aggression, social behavior". Empathy is a key element (and so are shame and guilt, both connected to empathy, which is a primary social emotion) in the sociology of emotions, which opposes basic (self-sufficient) emotions such as happiness or sadness to emotions that require a mental representation of others, are

linked to the development of social cognition (they imply the ability to describe the situation generating the emotions), and tend to be influenced by social norms (a person raised in an Orthodox Jewish community would have a feeling of guilt when eating non-kosher food that somebody not connected to that community would not experience). Relevant especially when talking about engaged/political/social theatre, social emotions are also moral emotions, because of their important role in moral behavior and moral decision-making.

For Davis (and again relevant when talking about theatre), the level of the empathic response varies according to the strength of the situation (a helpless person in emotional distress, for example), and the most important process (an advanced cognitive one) in “producing” empathy is *role-playing* or *perspective-taking*, understanding the other’s feelings by actively imagining them – something that modern theatre offers to intermediate, and the theatre in education practices actively explore.

Shame in documentary theatre

At some point in the first half of the Moldavian production *Clear History* (Laundry Theatre/Teatrul Spălătorie, Kishinev, 2012), the audience is asked to stand up and repeat what appears to be a pledge to the country. The number of people actually standing up varies (depending, I would infer after seeing the show in different cities and countries, on their degree of familiarity with participatory theatre and whether they recognize the text they are asked to repeat or not) but there are always people willing to cooperate.

The revelation of the true nature, anti-Semitic and signed by a notoriously infamous figure of the Romanian interwar politics (Marshall Antonescu), of the text they were supposed to assume by repeating has the effect of visibly shaming the standing members of the audience (visible, because shame as an emotion always has a physical component). They are going silent one after the other and sit back in awkward manners.

Well into the second half of Gianina Cărbunariu’s *X mm of Y km* (Colectiv A, Cluj, in 2011), which explores the possibility of finding the *Truth* in the files of the Romanian former secret police (Securitate), the spectators are asked to answer a question by moving their chairs on the side of the performers (if they agreed with the actors’ statement) or not (if they disagreed). Throughout the ten or so performances of this production that I saw, the willingness of the members of the audience to raise up, fold their chairs and move was always rather timid, and most of the ones that did it were either young or part of the theatre milieu. On one occasion, a spectator (who happened to be a theatre critic) loudly protested both the question and the invitation addressed to the audience.

Developed by theatre-maker Nicoleta Esinencu together with her regular team of actors, *Clear History* is a documentary theatre piece about the dispossession, deportation and killing of Jews following the entry of the Romanian Army in Bessarabia (currently the Republic of Moldova) during WWII. By the time the performers asked the audience to stand, the exact approach to the topic is still unclear, and there's no anticipation, yet, of the strong stance of the performance, blaming the Romanian nationalism and anti-Semitism (more than the alliance with Nazi Germany) for the Holocaust in Bessarabia. As very often in her artistic practice based on documentary materials, Esinencu combines a non-Stanislawskian, performative kind of acting (in which the performers are not playing characters/roles, they are using theatrical techniques in order to give testimony about the documented real facts) with a conventional stage dispositive.

X mm of Y km is a type of conceptual performance. Based on a five-pages long transcript of a meeting (secretly taped by the Securitate), in 1985, between a dissident writer, the president of the Writers' Guild and a communist official, it is a series of "failed reenactments" of how the meeting actually went, with actors continuously changing roles (they are casting lots initially, to decide who plays whom) in order to show the very relative nature of good and bad in a distorted social context. The line with which the performers invited the spectators to move their chairs (and the only moment when they directly addressed the audience) was: "Now (after 1990, *n.l.p.*) we have nothing. Those who believe that now we have nothing - take your chairs and come with me."

The examples are important in terms of how the "theatre of the real" (Martin, 2013) straightforwardly engages physically its audience especially because none of them is a participatory performance. Asking the spectators to actually (re)act to and interact with the actors in a performance that works within the framework of the conventional modern theatre tends to be highly atypical and marks a certain artistic strategy, connected to the political – and documentary – substance of the said performance. The documentary nature of both *Clear History* and *X mm of Y km* is important when taking into consideration their spectatorship, because of what Janelle Reinelt calls "the promise of documentary": "Spectators come to a theatrical event believing that certain aspects of the performance are directly linked to the reality they are trying to experience or understand" (Reinelt, 2011, 9). Hence, even if the documentary practice is not predicated on a zero-degree of theatricality (it is not entirely a "believed-in" theatre, as Richard Schechner calls the community-based theatre, in an article published in a 1997 issue of *Performance Research*), spectators are aware that any engagement of theirs in the performance has consequences and implications different than when dealing with pure fiction.

In retrospect, Gianina Cărbunariu herself notices the ambivalence of audience's reluctance to the direct address in *XY*: "They (the spectators, *n. I.P.*) had an issue equally aesthetic and related to content of the question, because for them, *back then* there had been something sinister, and now it's (somehow) better. Even much better, without any connection with what had been then" (Popovici, 2014). It is also worth noting that no press or Internet material commenting the performance spoke about that particular moment of the performance – hence, ignoring the only open reference to the present of the performance and the past and present social continuity. In the Romanian social context, suggesting that the present life, under a democratic order, is not by default superior, under any aspect, to life during communism is extremely problematic, even if the comparison takes into account social and health care, educational and job opportunities (and these are the elements which the actors refer to, in that particular moment of the performance). There is a distinctive potential of social stigma associated to criticism of post-1990 Romanian capitalism, especially in a discursive context not admitting the total discontinuity between the social realities from before and after December 1989, an attitude that Gianina Cărbunariu had taken into consideration when working on *X mm of Y km*.

The "aesthetic issue" that Cărbunariu refers to concerns less the actual aesthetics of her performance and more the expectations that the audience has regarding "regular" theatre (especially one that happens in a theatrical institution/a theatre building and is not explicitly marked as improvisational, interactive, participatory or community-based). Even if *X mm of Y km* is not constructed as a realist piece of theatre, the cultural context it addressed subjected its audience to the conventions of modern theatre in terms of audience passiveness. *X mm of Y km* was challenging this model in manifold ways: from the very beginning, the spectators were sharing the (lit) space with the performers (they were asked to take a folding chair and place themselves wherever they wanted in the performing space where the actors were already standing – and guiding the audience, if necessary). Because the conventions tend to be so strong, the spectators had the tendency to place their chairs in a circle, leaving an empty "stage" in the middle (in other words, reproducing the conventional modern separation between the audience and the stage). Then, the structure of the performance questions not only the possibility for a Securitate transcript to reveal the *Reality* and *Truth* behind it, but also the concept of Truth/Truthfulness on stage, the cornerstone of the Stanislavskian acting tradition. The show did this by experimenting with the practice of theatre rehearsals:

It seemed fascinating to get a text already written (...) and see what lies behind those words (...). In *XY*, this happens by testing the limits of the surveillance file as well as the limits of the theatre, through the resuming of text fragments. It's like in the theatre: you have a text, and from its data, you try to see how it could be transposed on stage. We were simply testing a reality through theatre means" (Gianina Cărbunariu in Popovici, 2014).

In comparison, just like most of Esinencu's productions (*antidót, A(II) RH+*, *Dear Moldova, May We Kiss Just A Little Bit?*, *American Dream*, etc., even *radical.md*, to some extent), the stage-auditorium separation is preserved in *Clear History* – a black box with frontal perspective, keeping the audience in the dark and the performers in full light on the other side of the fourth wall.

When writing about the predicament of the audience, Nicholas Ridout identifies the spectator's reaction to direct address with the affect of embarrassment, without identifying it with shame (he talks about shame later, following Giorgio Agamben's considerations on this emotion in *Remnants of Auschwitz: The Witness and the Archive*). He clearly places embarrassment in the field of psychology and philosophy, not sociology and social psychology. For Ridout, embarrassment is a physical manifestation of shame, sort of a "shame response" (the awkward manners in which spectators sit back in *Clear History*), generated by the direct address breaking the "machine of illusion" and returning/reversing the gaze or suddenly placing the spectator in full light. This breaking is a form of violence, exposing the spectator and making her/him extremely conscientious of her/his body. Ridout quotes psychologist Silvan Tomkins (who shares with Agamben and Emmanuel Levinas this idea that shame is felt in relation to oneself, not the others or the failing to rise to their expectations) saying that "shame is an experience of the self by the self. At that moment when the self feels ashamed, it is felt as a sickness within the self. Shame is the most reflexive of affects in that the phenomenological distinction between the subject and object of shame is lost". (Ridout, 2006, 88)¹

This interpretation might apply, to some extent, to *Clear History*, but not to *X mm of Y km*, where the audience is sharing the same space and light with the performers during the whole time, their uncomfortable exposure being part of the artistic concept. Even in *Clear History*, the exposure is voluntary, the spectators stand up willingly, and they do it in good faith, accepting to

¹ Tomkins' book on affects was published in 1963, before the development of the theories about the social role of certain emotions, which explains, maybe, why he doesn't approach them in a sociological context.

share the experience with the performers. To some extent, they are knowingly betrayed by the artists, on the benefits of enhancing the emotional efficiency of the performance.

But the specific subject of *Clear History* – the Holocaust – makes shame its most relevant emotional outcome, especially in the philosophical way in which Agamben and Levinas see it (in the sense that these emotions are not triggered by the representation of other's feelings coinciding with the person's shame reaction and have no connections with the person's own actions). Guilt and its good friend, shame, are inextricably associated with how survivors and large parts of the public opinion in countries where Jews were persecuted react to Shoah, even in Agamben's interpretation guilt and shame having a dual nature: they are felt *by* somebody *for* somebody else's behavior, which means that these emotions are directly related to the act of witnessing – the exact type of experience that historical documentary theatre is trying to reproduce (this also means that the other spectators, who didn't stand up, share the feeling of shame with those who did repeat the anti-Semitic statement). A spectator (who was not a professional theatre critic) writes about *Clear History*: "Although I was not an innocent spectator, before this spectacle of State cruelty against its own citizens and that of ordinary people against their peers (of a different ethnicity), I was overwhelmed with a sense of *horror and guilt*" (emphasis added) (Negură, 2012). This phrasing openly calls in Agamben's view that shame is the constitutive affective tonality of subjectivity, and the experience of shame derives not from culpability but from the ontological situation of being consigned to something that one cannot assume (Agamben, 1999, 105).

Another difference between the direct address moments in *Clear History* and *X mm of Y km* is their reverse dynamics: for the spectators who stand up to recite what proves to be an anti-Semitic discourse, shame is the consequence of giving up the comfort of spectatorial invisibility, while in *XY*, the anticipation of shame was what potentially prevented part of the audience to act and move their chairs, even if they agreed with the performers' statement. One might consider that anticipation of shame was also what prevented other members of the audience to answer the invitation in *Clear History*, but in fact, the context in which that invitation to participation comes doesn't offer the possibility to foresee the outcome (what prevents most of the spectators to stand up is their general lack of disposition to expose themselves and get out of the convention), while in *XY*, the audience was already placed in a different convention, and taking action, agreeing with a socially stigmatic political stance, would have exposed them as "political outcasts".

In fact, both mechanisms behind the direct address in *Clear History* and *XY* have political aims, intending to offer to the spectators a personal experience (in the form of a strong situation, in Davis' terms) in connection to the story on stage going beyond the passive empathic response. It is obvious that, exposing the audience to the direct experience of how easy it is for innocent "by-standers" to associate themselves to anti-Semitic statements, "the show presents a possible mechanism of indoctrination, psychological mimicry (asking the spectators to repeat a fragment of a speech by Hitler – *sic*) (Stoica, 2014; the confusion that a professional theatre critic makes between Hitler and Marshall Ion Antonescu, the Romanian responsible for the local anti-Jews policies, says a lot about what it was at stake in *Clear History* in terms of perception of history and responsibility). And this mechanism is meant to extend the spectators' experience from witnessing to symbolically participating in the horrific facts presented in the performance.

"Shaming" the audience appears to be a strategy willingly used in performances such as *Clear History*, just like provoking the members of audience to face a marginal political stance (with all its "shaming" potential) is an active strategy in *X mm of Y km*. Unlike empathy in most cases, shame is a highly negative feeling that generates a pervasive emotional and personal distress with an increased level of self-awareness. How (or if) a powerful emotional response among spectators reflects on real action is obviously impossible to find or measure, but this not even why these performances originally chose to expose their audiences to this range of emotions. The *real* emotional discomfort that requires a reevaluation of the self and one's own subjectivity is, in fact, the most political outcome that this kind of theatre seeks.

References

- AGAMBEN, Giorgio, 1999, *Remnants of Auschwitz: The Witness and the Archive*, trans. Daniel Heller-Roazen, New York, Zone Books
- DAVIS, Mark H., 2006 „Empathy“, in Stets, Jan E., and Turner, Jonathan H. (eds.), *Handbook of the Sociology of Emotions*, New York, Springer
- GREHAN, Helena, 2009, *Performance, Ethics and Spectatorship in a Global Age*, London, Palgrave Macmillan.
- MARTIN, Carol, 2013, *Theatre of the Real*, London, Palgrave Macmillan
- NEGURĂ, Petru, 2012, "Clear history la teatrul Spălătorie: un manifest de neuitare" / "Clear History at the Laundry Theatre: A Statement Against Oblivion", <http://petrunegura.blogspot.ro/2012/01/clear-history-la-teatrul-spalatorie-un.html> (accessed July 2015)

- POPOVICI, Iulia, 2014, "«1989 was not a real break with what had been». Director Gianina Cărbunariu about *Typographic Majuscule*", in *Parallele Leben / Parallel Lives: Ein Dokumentar-Theaterprojekt zum Geheimdienst in Osteuropa / A Documentary Theatre Project on Secret Police in Eastern Europe* (Berlin, Theater der Zeit)
- REINELT, Janelle, 2011, „The Promise of Documentary”, in Forsyth, Alison, and Megson, Chris (eds.) *Get Real: Documentary Theatre Past and Present*, New York, London, Palgrave Macmillan
- RIDOUT, Nicholas, 2006, *Stage Fright, Animals and Other Theatrical Problems*, Cambridge, Cambridge University Press
- STOICA, Oana, 2014, "Cealaltă istorie" / "The Other History", *Dilema Veche*, no. 557, 16-22 October (<http://dilemaveche.ro/sectiune/arte-performative/articol/cealalta-istorie>, accessed July 2015)

IULIA POPOVICI is a performing arts critic and curator. Her writing focuses on alternative Romanian and Eastern European performing arts scene, documentary theatre, and the social challenges of contemporary arts. She edited two books, commissioned by the Sibiu International Theatre Festival, on *New Performing Arts Practices in Eastern Europe* (Cartier, 2014) and *The End of Directing, the Beginning of Theatre-Making and Devising in European Theatre* (Tact, 2015).

Extension of Performativity by a BCI

ALEXANDRU BERCEANU, CĂTĂLIN CREȚU,
GRIGORE BURLOIU, DRAGOȘ CÂRNECI*

Abstract: In the project *inter@FAȚA*, the creative team developed various algorithms for the generation of music, starting from real time monitored EEG. Among the music generating algorithms, together with other models, an EEG alpha spectrum analysis software was used, which was based on the difference of valence of sensors AF3-AF4. The post-performance analysis signals the correlation of these valence changes (change of potential difference between the left and right brain hemispheres) with the most intense moments of the performance and, respectively, with the most marked alternations of performance styles. The use of music and of the background sound produced, based on the EEG, emphasizes, thus, a deep, stable structure of the performance, measurable and reproducible in a number of performances. The spectator's emotional participation is thus removed from its shroud of invisibility, and it becomes an element of visible action, accessible to other spectators. This paper looks into the work stage of the project in 2014; at present, it is developed according to the conclusions described herein.

Keywords: BCI, EED-based prediction of emotions, performativity, interactive theatre, participatory art, computer generation of music

For the 2014 *inter@FAȚA* performance, apart from the established performing means, such as the actors' or the dancers' action, the use of video-projects, the creative team has also employed the EEG monitoring of an actor and of a spectator. The EEG monitoring had a two-coordinate role:

* *Alexandru Berceanu, Associate Professor at UNATC Bucharest, e-mail: zberceanu@yahoo.com; Grigore Burloiu PhD candidate at the Faculty of Electronics-Telecommunications and IT of UPB, e-mail: gburloiu@gmail.com; Cătălin Crețu, Associate Instructor at the Electroacoustic Music and Multimedia Center of the National University of Music Bucharest, e-mail: catcretu@yahoo.com; Dragoș Cîrneți, PhD in psychology, specialized in affective and developmental neurosciences, e-mail: dragos.cirneți@brainperform.ro*

one directly performative, sound generation starting from the monitored EEG signal, and one more subtle, linked with the symbolic-semantic level of the representation, given by the use of real time prediction software for the emotional state of the monitored subject, in a documentary theatre performance on the issue of discrimination.

EEG, electroencephalogram, concerns the monitoring of cerebral electrical activity, by means of sensors placed on the scalp. EEG measures the electrical potential difference between the sensor and the scalp area where it is placed. Neurons have spontaneous and directed electrical activity; its frequency, phase and amplitude changes according to various factors, such as wakefulness, sleep, focus etc.; its organization is coherent, in waves both at neuron, neuron group level and at units of cerebral regions. Electrical rhythms have a role in the encoding and transmission of cerebral information. The potential difference recorded with the EEG represents the synchronous activity of thousands up to millions of neurons with an evenly steered spatial organization.

EEG use for sonification purpose is a procedure that has been used starting with the '30s:

During his postdoctoral studies with Alexander Forbes and Hallowell Davis at Harvard University (1933-35), Lindsley himself served as the subject for the premier public demonstration of EEG to the American medical community. Initially, Berger's work was largely ignored. It was not until five years after his first paper was published, when his results were verified by the pioneering physiologists E.D. Adrian and B.H.C. Mathews, that his discovery began to draw attention. In their 1934 article in the journal *Brain*, Adrian and Mathews also reported the successfully attempt to sonify the measured brainwave signals which they had recorded according to Berger's methods. While listening to his own alpha presented through a loud speaker, Adrian tried to correlate his subjective impression of hearing the alpha come and go with the activity of looking or not looking with his eyes. This was the first example of the sonification of human brainwaves for auditory display. (Zaccaria Giovanni Marco 2011)

The first artistic works that use EEG for music production appear starting with the development of experiments in the field of digital art or art produced with the new technical means of the '60, oscilloscope, copier, computer etc. One of them is composed by Alvin Lucier in 1965, *Music for Solo Performer*. In the composition, the alpha wavelength peaks were sampled and amplified by producing vibrations of percussion instruments

arranged on the stage. In the subsequent years, a number of artists and scientists experimented various methods of producing sound from EEG, often by using the possibility to control the change of the dominant wavelength by biofeedback training. Experiments peaked with the extended project *Cortical Art* by Roger Lafosse and Pierre Henry in the '70s, which was also released on vinyl. They proposed a sophisticated live performance system called *Cortical Art*, presented in various versions. As we can see in a video record¹, a small number of electrodes would be connected to synths that were handled by Pierre Henry; there were also moment when the sound was generated without external human intervention. A very interesting aspect is the mention of color changes in a TV image during Pierre Henry's performance, when he was being filmed, depending on the EEG activity.

Very early in the history of the EEG use, we observe both the possibility of self-control by training of the EEG activity, as well as the link between the external stimuli and this activity. These observations were the basis of most of the projects in the last two decades, enabled by the availability of the EEG technology, respectively by the appearance of EEG machines for the consumer audience. In the '70s, the first academic centers and laboratories for musical BCIs appeared, as well as for the use of other types of bio-signal (GSR or EMG) for the generation of music: one of the most important ones is the Laboratory of Experimental Aesthetics at York University, Toronto, by David Rosenboom. (GSR-is the galvanic reaction at skin level, used especially in the polygraph technique and EMG is electrical charge monitoring at muscle level).

At present, there are major attempts of EEG sonification in the diagnosis of brain disorders such as Alzheimer (Mohamed Elgendi, Brice Rebsamen, Andrzej Cichocki, Francois Vialatte, and Justin Dauwels 2013), in music therapies for the disabled, as well as other important research in the field (Eduardo Reck Miranda, Ken Sharman, Kerry Kilborn, and Alexander Duncan 2003). The BCIs that make use of EEG vary from control devices for individuals with locomotor disabilities to (sound or visual) sign selection systems, becoming communication interfaces.

Our intent with the *inter@FATA* performance was to symbolically employ, based on EEG-monitoring and subsequent sound generation, the spectator's and actor's synchronous actions, assimilated as involuntary performative actions linked with the continuous interaction with the environment of stimuli prompted by the progress of the performance.

¹ <https://www.youtube.com/watch?v=VzRvM64gv-4>

Particular interest was vested in the relevance of the electrical activity in relation to emotions and the current BCIs developing this type of application of recognition of emotion-related parameters.

The topic of *inter@FAȚA* is discrimination in the Romanian society, researched mainly on three communities: the Jewish, the Roma and the homosexuals. Among methods specific to documentary theatre, the audience is told various tales of discrimination, placed at various historic times. The performance proposes a deeply participatory action, in an open convention that invites the audience to take part in various tasks and actions of the representation.

Before they enter the hall, the spectators receive a pink or a red card. They are greeted in the performance hall by the actors who dance and who invite them to do it, too, or to sit, according to the color of this card. Once they are seated, the *meneur du jeu*, Paul Dunca, explains the division in two categories: red-spectators, pink-volunteers. The spectators will watch and applaud and some of the volunteers will be selected to be EEG monitored. The performance then shows monologues or scenes where the subjective choices are the nodal point. This venture into the typologies of “choice” starts from the one carried out by some children for a football team and peaks with the selection for elimination of the Jewish or Roma individuals. The performance creates a parallel between these discriminating choice circumstances and the repeated choices of the EEG monitored subjects, enacted by the actors. The most transparent connection is made by a spectator’s selection by height, by having the “pink” spectators go under a meter like in the story told by Octavian Fullop, Auschwitz survivor, who describes how Mengele had all the young men pass under a board fixed at the height of one of the tallest prisoners, and those who could not meet the standard height were killed by gassing.

The performance alternates moments of full relaxation with emotionally-tense ones, for the purpose of “refreshing” the spectator’s emotional state. The theatrical modality applied is that of suggestive theatricality, with minimal setting elements, and with spaces designed by the actors’ actions or by stage directions. In the fragment dramatized with Vasile Nussbaum, starting from his testimony of camp survivor, directions on the description of the setting are spoken and the space is configured from minimal modular setting, abstract elements (50/50 wooden cubes). The fictional nature entailed by the theatrical representation of some events is broken by the presentation of the legal situations – the reading of the laws that led to the discriminatory events depicted in the performance.

EXTENSION OF PERFORMATIVITY BY A BCI



Fig. 1 and 2: Images from the representation: Picking one of the monitored subjects, *inter@FAȚA* 3 2015, Replika center

In this context, we thought that exposing the spectator's subjectivity gains a symbolic value, while we tried to outline the dialectic of subjectivity that creates identity in an approach/rejection process. We tried to offer elements that could ready the spectator's imagination toward self-analysis relating to this aspect of "approach-rejection", by circumventing the creation of a barometer interface and by choosing, instead, a symbolic one.

Methodology

The methodology employed for the EEG monitoring was similar with the ERP (event related potential) EEG investigation technique, whereby a subject is given a stimulus that triggers an electrical response at brain level. Neuro-marketing developed this type of research by using emotional and cognitive analysis software to investigate the brain electrical response to the design of specific products, ranging from cars to fiction films; thus, information was obtained on the consumer's emotional response (at present, neuro-marketing also uses fMRI techniques for the same purpose).

During the performance, a subject from the "volunteer zone" is selected, together with the actor who wears the EEG headset. The volunteer is replaced in the first two parts of the performance. In the last part, the headsets are worn by two volunteers. The spectators are warned from the beginning about the use of EEG and they are also given basic information on the use of the machine. During the representation, they receive additional information on how the EEG signal is used, including the fact that an emotion-prediction software is used. The creative team tried to have invisible or even volatile parts of the spectators' and, respectively, of the actors' reactions reach a perceptible and even measurable level. The team found this was especially relevant to the theme of the performance, since discrimination by the emphasis of the hidden layers of emotions, along the "approach-rejection" coordinates, can generate particular significations in the presentation of discrimination accounts.

Instruments

Instruments: Two Emotiv Systems 114-channel EEG headsets were used (AF3, AF4, F3, F4, FC5, FC6, F7, F8, T7, T8, P7, P8, O1, O2) with a 128Hz sampling rate, and 0.16-43Hz frequency response. For visualization, Emotiv TestBench EEG signal monitoring software and Affectiv Engine emotion predictive software were used; the latter produces five parameters: frustration, temporary interest, commitment and contemplation. The five values are given by proprietary algorithms and they are transmitted at a rate of 1Hz.

EXTENSION OF PERFORMATIVITY BY A BCI

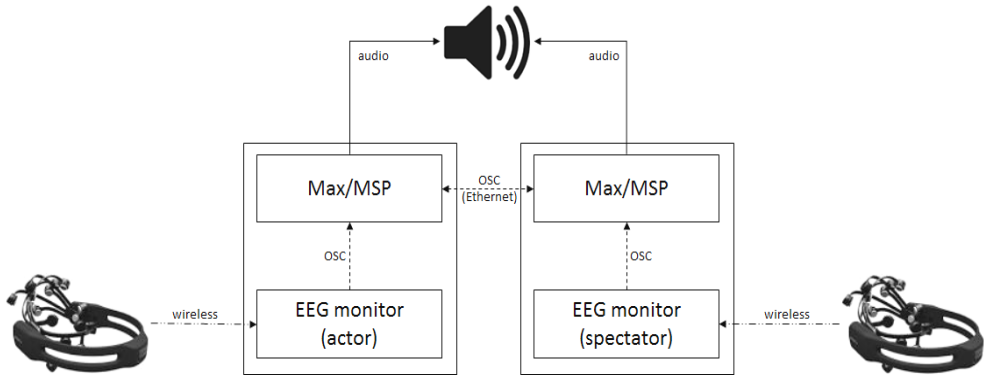

The EEG monitoring component is specific software developed in C++ in the project, which interfaces directly with the Emotive API, for the real time processing of the signal transmitted by the EPOC headset and for its further transmission to Max/MSP (or, potentially, any software that recognizes the OSC protocol). Furthermore, a secondary feature is the taking of EEG EDF (such as those produced by Emotiv TestBench) for tests and analyses without an EPOC headset.

The processing of the EEG signal occurs in a thread synchronized at the computer clock, which ensures the transmission of the OSC packs at the right time. A buffer is loaded with the relevant values (either straight from the EPOC headset or from the EDF file); a signal limitation process follows, for the removal of artificial peaks and of the continuous component of the signal, by translating it around the value zero.

The EEG signals in the AF3 and AF4 sensors are furtherly FFT transformed for the extraction of the delta, theta, alpha and beta values. The Hamming-weighted FFT buffer has 128 values, which leads to 64 spectral bins. Bin values are squared to obtain the spectrum of powers. The 4 fields (delta, theta, alpha, beta) are linked each with a bin range, and the value of the wave is given by the ratio between the power of the largest bin in the range and the total power of the spectrum. To the set of values we add the 5 mental states (values between 0 and 1) in Affectiv Engine, which come directly from API. The OSC pack thus obtained is sent to Max/MSP, at 1/s rate.

Apart from the four abovementioned mental states, the EEG data of the 14 channels are sent at the same rate.

Methodology of sound generation starting from the EEG

The performance's soundtrack generation strategy is based on the execution of interactive algorithms – with the Max/MSP software – that are influenced in real time by the variation of the parameters given by the EEG analysis and it follows two guidelines: the use of data obtained from the five curves given by the emotion prediction software (translated by s-valence) and the spectral-acoustic transformation of the gross values received by each of the 14 sensors attached to the subjects' scalp.

The correspondence of the five emotions and the musical parameters is done in the following manner: temporary interest is linked with the tempo (weak interest – slow tempo, increased interest – fast tempo); short-term commitment is linked with the change rate of sound peaks (weak commitment – imperceptible changes, strong commitment – quick changes), long-term commitment is linked with long sound, “acoustic traces” of temporary commitment; frustration is matched with a tune that accelerates and goes up in acute tones proportional to its increase, while contemplation is matched with long, variable, harmonic intervals. Tone qualities (timbres) were selected to sustain as close as possible the dramaturgic ideas. The 5 musical entities thus obtained generate – by overlapping – heterogeneous musical syntaxes, with different densities.

Parameters from the 14 electrodes are matched with numeric values that are later used in the generation of sinus sound overlapping (three at a time), activated and modified by the variations of other parameters or the involvement in noise resonance processes.

Other components used in the generation of sound, starting from the EEG, were:

1. the rhythmic component, which meant the running of an audio sample (gamelan notation, typewriter, vehicle noises etc.) in a two-dimension *wavetable*. We obtain the repeated play of the sample, at different rates and start/stop positions. Parameters: position & play rate (on axes X and Y), stereo delay time

2. tonal components (see the aforementioned sine waves: parameters: frequencies & amplitudes of the sinusoids

3. Granular resonator component, which divides an audio sample in short grains that give a sound texture from which certain resonance frequencies are marked. Parameters: play rate, height, duration of grains, resonance frequencies.

The control of the aforementioned parameters is either prearranged or dynamically assigned, depending on the moment of the play. For the dynamic assignments, we created a system of macros that describe the control relationship

between the input values and the musical parameters. The relationship versions are:

- similarity – extent to which two values evolve in the same direction;
- opposition – extent to which two values evolve in opposite directions;
- coincidence – activation when two values are equal;
- simple proportionality – direct matching of a selected value.

Finally, the macro output can be *VALUE* or *BANG*, respectively a quantification of the relationship or only one pulse when the relationship is activated (e.g., when the two value begin to evolve in the same direction).

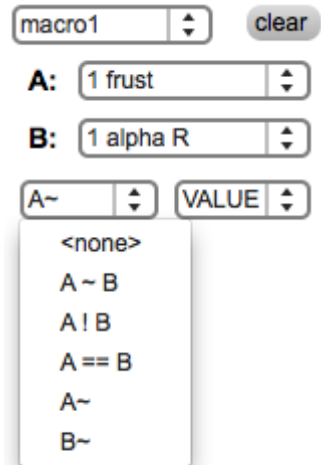

Preparations

During rehearsals, the EEG signal was monitored in order to test the prediction capability of the software offered by the EEG headset manufacturers; major connections were noted at the monitoring of the actors' post-evaluative reports, the observation during the representation and post-representation, based on the recorded material. *Eight* sessions were conducted, and *seven* of them monitored both an active subject, actor, and a spectator-subject. During monitoring, we noted strong dynamics of the degree of frustration and some correlations with temporary interest, as well as relatively strong dynamics of commitment and a low contemplation one. In all cases, the moment that was self-reported as the most emotional one, both by the actor and by the spectator, coincided with moments of marked shift in the dynamic of the emotion-related software parameters. The parameters *frustration* and *interest* were found not to be influenced by the actor's speech; the parameter *commitment* was considerably more sensitive to movements, its monitoring being automatically interrupted by the software in the presence of movements. At a subsequent correlated analysis of the image of the subject/EEG and of the emotion prediction software, the existence of "noise" in the EEG was found around or just at the time when the parameter was changed in the prediction of the emotional state. We also noted an important change in the parameters visibly linked with focus, involvement and emotion: acceleration of breathing, change in the color of teguments, change in the blinking rate. In an analysis

of the material, performed with Raul Mureșan and Vlad Moca, from RIST (Romanian Institute of Science and Technology), Cluj, we concluded that, particularly at the actor, it is impossible to establish with certainty the extent to which emotional dynamics is estimated by the software based on the electrical activity at scalp level or on other electrical activities, such as those generated by face muscles, although a marked connection between the emotional activity and the parameters of the manufacturer's software was found. The movements of facial muscles, of the eyes, of the cheeks or of the phonatory system generate electrical current, like the movements of the limbs that overlap the electrical charges detected by EEG at scalp level, which leads to the appearance of elements that are not driven by the brain electrical activity in EEG monitoring; these elements are called artefacts. We concluded that, without the use of a complex artefact removal software, the EEG monitored data from a subject who does not speak is not scientifically analyzable.

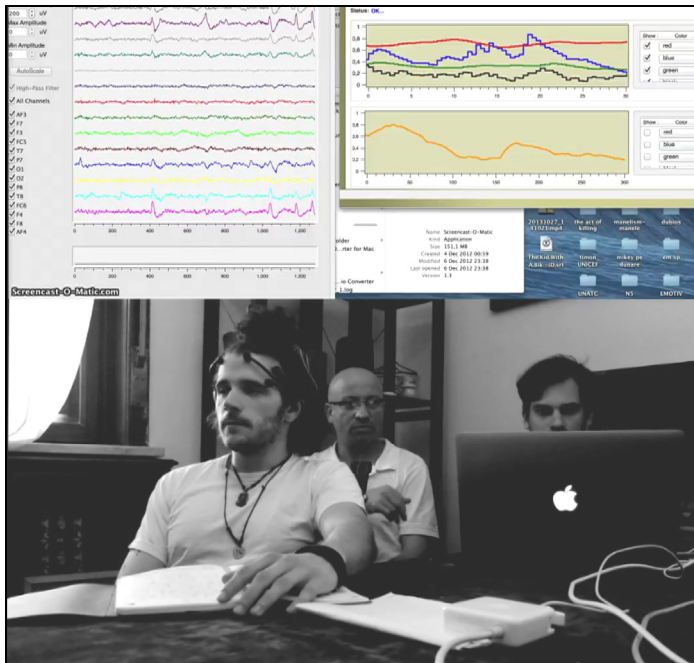

Fig. 3: EEG Screen and Emotion prediction software screen captures from the measurement synchronized with the recording of actor Liviu Popa during a test monitoring scene. At the upper left side, the screen of the EEG monitoring, at the upper right side, screen of the emotion prediction software Affective Suite, red curve – commitment, black – temporary interest, blue – frustration, green contemplation, orange – long-term interest.

After the analysis, we concluded that the software is relevant in the prediction of emotional state changes, especially in the attention range, *which was, otherwise, predictable, because the EEG band changes between the alpha length to gamma indicates an increased extent of cognitive activity and, thus, an increase of attention. This allows the execution of an emotion prediction model even if exclusively on the inclusion in a real time analysis software of the shift of the EEG spectrum from the alpha wavelength to gamma.* Since we could not estimate the importance of the other electrical parameters in the operation of the proprietary software, while also considering that the type of analysis could not be included in a scientific report without additional information from the manufacturer on the operation of the software, we established the necessity to develop our own model of analysis in real time of the EEG.

From the scientific literature, we selected an emotion prediction methodology based on the valence difference between the prefrontal sensors AF3-AF4, since the valence change was linked, in various studies (see Jones, N.A., Fox, N.A 1992), with the change from the state they “feel good/feel bad”, respectively positive emotion/negative emotion:

The asymmetrical frontal EEG activity may reflect the valence level of emotion experienced. Generally, right hemisphere is more active during the experience of negative emotions while left hemisphere is more active during positive emotions. It was found that when one is watching a pleasant movie scene, a greater EEG activity is appeared in the left frontal lobe, and with unpleasant scene, right frontal lobe shows relatively higher EEG activity. (Jones, N.A., Fox, N.A 1992)

This connection was emphasized by numerous studies (see James A. Coan, John J.B. Allen 2004), on various types of stimuli, sound visual film, advertising or face recognition:

Over 70 published studies have now examined the relationship between emotion or emotion-related constructs and asymmetries in electroencephalographic (EEG) activity over the frontal cortex. A review of these studies suggests asymmetries in frontal EEG activity – including resting levels of activity as well as state-related activation – are ubiquitous and involved in both trait predispositions to respond to emotional stimuli and changes in emotional state. (Coan J.A.; Allen J.J.B 2004)

The relationships of the alpha wavelength spectrum at the frontal lobes with the emotional state, as well as with the cognitive processes, are extremely complex and studied *in extenso*; the alpha rhythm is the first one that was discovered and perhaps the most investigated of the brain rhythms. The aim of our research was not to generate new clarifications, but to apply knowledge from neuroscience to performing arts. However, several explanations are required for the emphasis

of the aspects to be described later: the frontal cortex is engaged in mainly cognitive brain activities, while emotional processes are linked with the deeper structures of the brain, respectively the limbic system. The role of the frontal cortex at the level of emotional processes is that of a moderator and a mediator, an aspect also shown at the level of the EEG activity, see James A. Coan, John J.B. Allen 2004. Moderator means:

Moderators are essentially third variables that represent conditions under which some independent variable becomes maximally potent or effective, while mediators:

Mediators, by contrast, are third variables that represent the mechanism through which (or partially through which) the effect of a given independent variable is made manifest. For example, if one of the components of an ordinary fear experience is a motivational tendency to withdraw, then eliciting that component of fear might require activity in the brain systems tapped by frontal EEG asymmetries. (*Ibid.*)

The frontal cortex of both lobes has a very important role in the conscious processes of the brain; this aspect turns it in the preferred object of research regarding emotions and of EEG, with the EEG observations allowing comparisons with self-reporting.

After we analyzed several models, we came to the real time emotion recognition methodology developed and described by Yisi Liu, Olga Sourina, and Minh Khoa in their paper "Real-time EEG-based Emotion Recognition and its Applications". It considered a dimensional (quantitative) model wherein emotions are distinguished by the positive or, respectively, negative valence and by intensity (extent of excitation), which varies from zero upward. The aforementioned team's objective was to recognize, with EEG, six different emotional states: fear, frustration, sadness, happiness, pleasant, satisfied, in real time, starting from standardized visual stimuli, and their research reported a success rate of over 80%, while other studies indicated 90% success rates (see Lin, Y.P., Wang, C.H., Wu, T.L., Jeng, S.K., Chen, J.H., 2009)

Given the artistic purpose of the *inter@FAȚA* experiment, some of the complex elements of analysis of the signal were removed from the described methodology and replaced by a simplified calculation version in MAX MSP, the EEG data being saved for a later analysis, at a small 1Hz resolution, which allowed the running of music generation software in real time.

During the performance, the use of this element was exclusively artistic, present only by sound, the change of potential from left to right and the reciprocal being a trigger of sound algorithms. The interpretation of the recorded data was carried out subsequently and their scientific validation requires more sessions, better resolutions and more stable work conditions.

Unlike a laboratory environment, where the assayer offers to the subject an extreme stimulus for control, which approaches only one cognitive and emotional/perceptive level, during the performance the subject/spectator finds himself in a complex environment, with numerous visual and auditory stimuli, following complex information and experiencing various emotions. Furthermore, the theatre spectator selects constantly, independently, the parts of the performance on which he focuses. For this reason an “instantaneous electrical reaction” analysis was deemed slightly relevant, the post-performance analysis being an analysis carried out for the entire representation (which lasts for almost three hours) on the subjects who were monitored. Since the actor was moving too much to allow a clean EEG signal, their EEG was not analyzed, although it was used in the generation of sound and it will be possible to involve it in a later analysis, with the mentioned reserve.

During the performance, the following records were made: four performances on audio-video record, EEG signal record both for the spectator and for the actor, at 1Hz sampling rate on all the 14 channels; as well as at the level of the parameters, of the Emotive Engine emotion recognition software.

Post-performance analysis

After the post-performance analysis, we focused on the signal recorded with the C++ patch. The analysis was carried out with the software described in the paragraph on the instruments and with the EDF browser software, which generated the visual reports of the difference of potential between the AF3 and AF4 sensors (the odd number indicates position on the left hemisphere, while the letter indicator signals position on the cranial region, respectively frontal AF). Later, the qualitative analysis was performed for the ratio between the obtained diagram and the narrative flow of the performance.

For this purpose, a synchronization of the recorded EEG signal with the video record of two of the representations was operated, which allowed an accuracy of approx. 30 seconds. An analysis was performed in the alpha spectrum of the difference of potential between the AF3-AF4 sensors. Once the difference between the two values was obtained, a filter (LP butterworth) was applied for the removal of differences below 0.01Hz, in order to obtain an overall image of the chart. For the analyses, the EDF browser was used². The curve is given by the difference of the instantaneous value, monitored each second, of the value recorded by the AF3 sensor and of the value recorded by the AF4 sensor. Therefore, a peak indicates a larger value of power in the left

² <http://www.teuniz.net/edfbrowser/>

The analysis of the diagrams shows, at first sight, that they are very different for each of the 6 subjects (three per representation); furthermore, we note a relatively linear structure (with maximum and minimum values equal in time) for an overall duration, as well as considerably, above average, high peaks and values considerably lower than the average minimum. We also note zones at a subject where a several minute layout is seen in the inverse of the anterior average. Given the conclusions in the literature, we decided to approach only these moments, the shift of the monitored power from the left frontal hemisphere to the right and reciprocally being the sign of a change of state at the monitored subject. Approx. 30 such events were identified in the diagram, of which we describe the most important ones. We note that each spectator was monitored during a segment of time of the performance; therefore, the decision to analyze a maximum value, respectively a minimum value of the diagram, concerned first of all the structure of a unit (i.e. a subject) and not comparatively, since the observable peaks had very different values at different subjects.

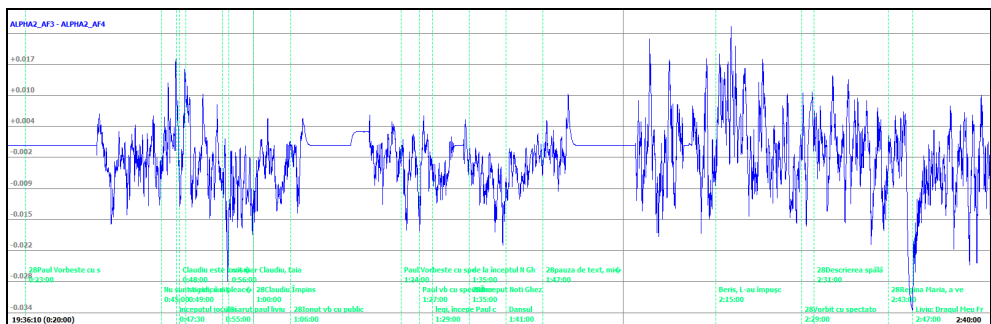

Fig. 6: Analysis of AF3-AF4 valence on 28 October

Since the beginning, in the analysis of the 18 November representation, we note a moment with a peak considerably above average, at 1h:19 of the performance. This is a maximum both at the subject A2.2, and compared with the other subjects. The moment is the testimony of witness Notti Gezan, who recounts how Jews were tortured to confess where they hid their treasures, how they were beaten and controlled to the bone, children included. The episode evokes the most marked cruelty recounted in the performance. While listening to the sound generated during the performance in the complete video record, we note the acceleration of the tune and the ascension to the acute tone, an algorithm in direct proportion with the parameter of frustration. This aspect was found in the sound of all the representations.

28-Oct	18-Nov			
Video IN	Video IN	Description of moment	Type AF3-AF4 28/10/14	Type AF3-AF4/18/11/14
00:15	00:27	I am not a gipsy, I am Greek, followed by sirtaki	minimum according to the notation on diagram 28.1	maximum
00:16	00:28	beginning of the football match with Claudiu	maximum	maximum
00:17	00:29:30	Claudiu stands up and leaves after a foul/or foul moment	maximum	maximum
00:17	00:29	Claudiu is hit and falls down during the match	minimum	minimum
00:29	00:43	Claudiu is pushed by neighbor	minimum	minimum
00:24:17	00:36.40	Paul Liviu kiss	minimum	minimum
00:24:56	00:37.16	Claudiu's fingers are cut	minimum	minimum
00:28:18	00:40:30	Close to the neighbor's cry "You gipsy"	low maximum	low maximum
00:35:10	00:48	Ionut talks with the audience about discrimination in RO	maximum	maximum
00:52	01:05	Paul talks with the spectator, describing the parameters	minimum	minimum
00:52	01:05	Paul talks with the spectator	minimum	minimum
00:56	01:09	laws, beings Paul in front of the spectator	<i>negative</i>	<i>negative</i>
00:57	01:10	Paul talks with spectator, then when Cătălina speaks, increases, music increase heard in the sound		
1:04.38	01:15	Begin Notti Gezan	series of markedly descending moments	series of markedly ascending moments
	01:15	from the beginning N Gezan to the end	positive interval	negative interval

EXTENSION OF PERFORMATIVITY BY A BCI

28-Oct	18-Nov			
Video IN	Video IN	Description of moment	Type AF3-AF4 28/10/14	Type AF3-AF4/18/11/14
		Bercovici		
	01:18:19	Beaten sister	Maximum	minimum
01:10	01:19	Dance	brief negative interval in the aforementioned positive interval	brief positive interval in the aforementioned negative interval
01:16	01:29	text break, vey ample choreographic coat movement	minimum, below zero	minimum, below zero
02:23	02:07	Talk with spectator, Liviu: Description of Auschwitz, great changes of light and sound		
02:25	02:10	Description of washing and disinfection at Auschwitz		
02:31	02:16	Liviu: My dear brother	minimum	minimum
02:37	02:20	Queen Mary came/Judith Tata		

The analysis of the subsequent sequences found that all the peak positive and negative moments were linked with intensely emotional situations or with strong shifts of focus. An important series of moments that showed a positive peak (a negative emotion) was given when the actor talked directly to the monitored subject, which is often intimidating. Another important category of negative range moments, respectively from the range of positive emotional activation, is given by intense embodiment moments. If intense embodiment was followed by violent narrativity, both positive and negative peaks were registered, even for the same moment linked with another monitored subject, during another performance. The episodes of suggested fictional violence, for instance the cutting of Claudiu's fingers in a nightmare, with a slightly surrealistic touch, were linked with a positive peak, corresponding to negative emotions. We note that this moment, easily seen in the chart of both performances, was followed by a marked shift in light design and background sound, which prompts automatically increased focus; the sinusoidal sound linked with this episode is generating distress.

Discussion

The study performed by Nancy Aaron Jones and Nathan A. Fox, “*Electroencephalogram Asymmetry during Emotionally Evocative Films and Its Relation to Positive and Negative Affectivity*”, on 23 subjects picked according to scores obtained by their self-characterization on the amount of positive versus negative emotions they felt, noted:

The data show that the happy video clip produced greater relative left hemisphere activation than the sad and disgust emotions. The sad and disgust emotions showed greater relative right hemisphere activation than the happy emotion (see Fig. 1). No other main effects or interactions were found.

Their prominent study meant to clarify the issue of brain functional lateralization, including perspectives on the assertion that the right hemisphere is specialized for rational judgment, while the left one for emotional processes. At that point the existence of emotional processes in the right hemisphere had already been emphasized, and the dismantling of the mentioned assertion had begun. The thorough analysis shows that most of the reported negative emotions were correlated with an increase of activation in various brain areas (frontal, temporal, parietal) in the right hemisphere, while positive ones were correlated with the activation of the left hemisphere. Moreover, correlations were found between the activation strength and the type of personality, positive versus negative.

An interesting element results from the AF3-AF analysis of the 28 October performance, by the spectator report in the second segment of the play. This report is obviously favorable to a considerably stronger and more extended activation linked with the right hemisphere, unlike all the other spectators. One possible interpretation might be that the subject experienced instead positive emotions during the representation. Albeit possible, this is unlikely, because a careful analysis finds that we have negative peak exactly during the testimony of Notti Gezan – as said, the most brutal event recounted during the performance:

Fischer Margareta, interrogated by Boldizar Paul, who, to intimidate her, punched her so hard in the mouth that two teeth fell, while he kept throwing dirty words at her. Then he made her lie on a bench and hit her everywhere, genitals included, until she passed out. While she was being beaten, my sister was screaming with pain; he made her remove her socks, which he used to gag her, while continuing to hit her feet with a baton. When she recovered, at Boldizar’s order, the torturers there, namely from Huedin - Szentkuti Andrei, detective – put pencils between her fingers and then pressed her hand until she passed out again and this is how we took her out in the barrack. My sister Margareta never returned from deportation.



Fig. 7: Image from the representation, actress Cătălina Bălălaşu at the testimony of witness Notti Gezan, EEG monitored

Given the gender of the monitored subject, i.e. female, a positive emotional reference to this moment is unlikely, the observed phenomenon being explained rather by a different lateralization of left right valence asymmetry, associated especially to the left-handed, but not exclusively (see Hamann, Canli, 2004 and Lin, Y.P., Wang, C.H., Wu, T.L., Jeng, S.K., Chen, J.H 2009). For this reason, recognition BCIs required the scaling of each subject, to enable precision.

Going back to this point in the testimony of witness Notti Gezan, starting from the premise that the subject had an opposed lateralization of the valence, we find a strong link between the peak characters of the two moments. According to the creative team's expectations, it was estimated as the most intense moment of the performance, added to the one when the surviving Auschwitz witness, Vasile Nussbaum, recounts how he read the

last letter from his 13-year old brother Alex, before the latter was gassed. This moment, too, was marked as followed by positive peaks, for one of the monitored subjects, in relation to the overall monitoring process.

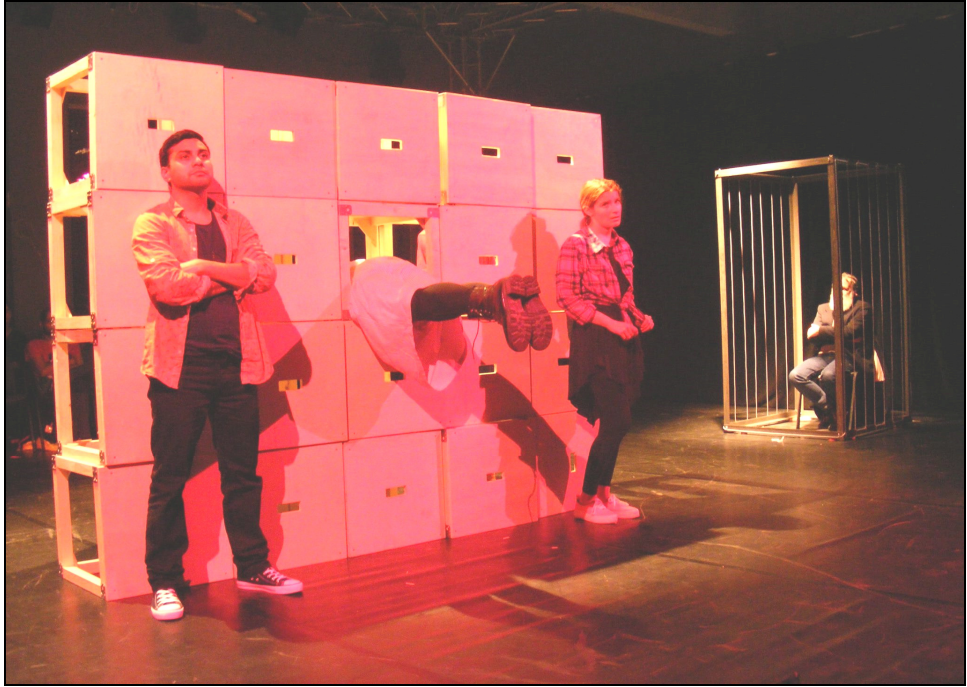

Fig. 8: Image from the representation, actors Cătălina Bălălău and Ionuț Niculae

Conclusions

The role of the EEG alpha waves continues to be debated; currently, there are two directions: one that links them with sensory processing, and the other one with the allocation of attention. The majority of the data, including the correlation of EEG data with functional MRI data, pushes towards the latter hypothesis, respectively towards a role in the downward modulation of attention allocation (the one oriented externally and the one oriented internally), the neural sublayer being found in the right frontal cortex. How could such data come to terms with the data that involves frontal areas in emotions, as shown previously? In their neuro-computational model, Gray and Braver (2002) describe numerous proofs that suggest there is an integration of emotional states and of cognitive control at the level of the lateral pre-frontal cortex. This conclusion

relies on the selective effects of emotion induced on behavioral performance and on brain activity. An integration of emotion and cognition could have an important computational role in self-adjustment, state the authors. An integration mechanism would enable selective self-adjustment, dependent on the emotional state, which also depends on the assessments of the situation. Approach/avoidance states may modulate in a differentiated way the subsystems of attention/working memory, for the priority of specific purposes in a manner sensitive to the events in progress. According to Gray and Braver's model, constant attention is considerably more important in states of avoidance, when emotions such as fear appear, to enable an extended processing of a potential threat. Failure to sustain attention or vigilance in such a situation would be disastrous. Constant attention and attention orientation are mainly localized in the right hemisphere, and experimental evidence indicates a facilitation of constant attention in states of avoidance.

The creative and analytical use of a brain-computer interface is within range for performers and performance creators, and it offers sufficiently rigorous and reliable instruments for the integration in the performance. The development of certain forms of plays that enable the inclusion of the actors' EEG assessment, as well as the improvement in the reliability of tools to obtain consistent results at this level could allow new perspectives on the relationship between the actor's experience and the spectator's.

The inclusion of the performer's analysis in a study requires, however, a considerably stricter experimental chart, which should limit to the maximum extent the actor's movement, or the experiment with systems of analysis able to remove speech- or movement-related artefacts.

Given the general conclusions of the studies on the different activation of the left frontal hemisphere versus the right one, in relation to positive versus negative emotions, we have concluded that the appearance, at the EEG test, of such a difference, signals a major change of state (even if it cannot explain specifically the type of emotion experienced by the subject), as expected if we consider the literature and the post-performance analysis – an indicator we find extremely pertinent for the subject of the performance and which will be integrated in an upcoming version.

Development possibilities for the 2nd version of the performance, prospective development

The development of the *inter@FAȚA* experiment is considering three coordinates: artistic, technical conditions, and research conditions. To improve the technical conditions of the project, the possibility to synchronize EEG signal

sources with the video witness of the performance and with a potential video record of the monitored subject is vital; it will allow the accurate assessment of the effect of the subject's movements and of the relationship with the contents of the performance. Furthermore, the use of more reliable equipment, which should allow better and longer contact for a definite signal, will enable the improvement of the scientific value of the data. Moreover, the use of a solution less influenced by the subject's movements, e.g. EEG equipment used in the monitoring of sportsmen, could give good results for the investigation of the actor subject; we note here that the level of speech generated artefacts should be measured and eliminated, which is hardly achievable, if not even impossible. For the purpose of accuracy, an auto-report is also required at the end of the EEG monitoring of each subject.

For the accuracy of the emotional states, we may consider an analysis of the EEG spectrum, which will provide data on the subject's degree of attention and commitment, based on the examination of the dominant EEG bands (alpha, beta, and gamma).

At an artistic level, the event of change in the propensity of the left-right and reciprocal EEG activity will be associated with the generation of an unequivocal sound, which could emphasize for all the spectators the presence of such a moment. By associating a moment of the performance with this type of sound, the audience will be signaled that a special intense moment is in progress and they will be able to compare it with their own response to the said moment. Since it is assumed that such moments are strong ones, it is most likely that reactions will coincide at most of the spectators. We are considering the association of this type of signal with the control of lighting by DMX protocol, starting from the association of some color with a positive, respectively negative state of mind. Additional to these development, we may consider the inclusion of an analysis in the mu spectrum, linked with the activation of mirror neurons, which could provide a connection with the actors' movement on stage; this element could be developed in a wide range that could associate movement and sound.

The project team:

Alexandru Berceanu – stage director and dramaturge

Andreea Chindriș – dramaturge

Actors: Cătălina Bălălaşu, Paul Dunca, Ionuț Niculae, Liviu Popa

Ana Costea – choreographer

Cătălin Crețu – music coordinator

Grigore Burloiu – programmer

Maria Draghici – video artist
Adina Babeş – document researcher.

The project *Inter@FAȚA* was carried out, with non-refundable AFCN financing, by the dramAcum association; at present, a new version of the performance is in progress *inter@FAȚA3* with non-refundable financing from AFCN and ARCUB, Center of Cultural Projects of the Mayor's Office, Bucharest Mayor's Office, with equipment from UNATC, the CINETic center.

References

- ADRIAN, E.D., and MATTHEWS, B.H.C. (1934) "The Berger Rhythm: Potential Changes from the Occipital Lobes in Man." *Brain*, 57(4): 355-8
- COAN James A., ALLEN John J.B. (2004) Frontal EEG asymmetry as a moderator and mediator of emotion, *Biological Psychology* 67
- EDUARDO Reck, Miranda; SHARMAN Ken, KILBORN Kerry, and DUNCAN Alexander (2003) "On Harnessing the Electroencephalogram for the Musical Braincap", *Computer Music Journal Summer*, Vol. 27, No. 2, Pages 80-102 MIT PRESS
- GRAY, J. R., & Braver, T. S. (2002) "Personality predicts working memory-related activation in the caudal anterior cingulate cortex". *Cognitive, Affective, & Behavioral Neuroscience*, 2, 64-75
- HAMANN, S., CANLI, T.: "Individual differences in emotion processing". *Current Opinion in Neurobiology* 14(2), 233–238 (2004)
- Jones, N.A., Fox, N.A. (1992) "Electroencephalogram asymmetry during emotionally evocative films and its relation to positive and negative affectivity". *Brain and Cognition* 20(2), 280–299
- MOHAMED Elgendi, BRICE Rebsamen, Andrzej CICHOCKI, Francois VIALATTE, and Justin Dauwels (2013) "Real-Time Wireless Sonification of Brain Signals": *Advances in Cognitive Neurodynamics* (III), DOI 10.1007/978-94-007-4792-0 24, © Springer ScienceBusiness Media Dordrecht
- LIN, Y.P., Wang, C.H., Wu, T.L., Jeng, S.K., Chen, J.H. (2009) EEG-based emotion recognition in music listening: A comparison of schemes for multiclass support vector machine. In: *ICASSP, IEEE International Conference on Acoustics, Speech and Signal Processing - Proceedings*. pp. 489–492. Taipei
- ROSENBOOM David (1997) *Extended musical interface with the human nervous system assessment and prospectus leonardo monograph series* International Society for the Arts, Sciences and Technology (ISAST) San Francisco, California, U.S.A. Original 1990, Revisions to Parts 5 and 6 and additional Appendixes
- Zaccaria Giovanni Marco (2010/2011) "Sonification of EEG signals. A study on alpha band instantaneous coherence". UPF MASTER THESIS University Popmpeu Fabra Barcelona

YISI Liu, Olga SOURINA, Minh KHOA (2011) "Real-time EEG-based Emotion Recognition and its Applications". Volume 6670 of the series *Lecture Notes in Computer Science* p. 256-277

WINKLER, Irene; Mark Jäger, Vojkan Mihajlović, and Tsvetomira Tsoneva (2010) "Frontal EEG Asymmetry Based Classification of Emotional Valence using Common Spatial Patterns" *World Academy of Science, Engineering and Technology* 69

ALEXANDRU BERCEANU: independent stage director. He staged more than 15 plays in independent and state theatres, which were awarded national and international prizes. Owing to his interest in new dramaturgy and in the extension of performing expression scopes, Alexandru Berceanu contributes to interdisciplinary projects of neurocognitive research of performing arts and in the visual field, such as 1958-1958 *Subversive and Immersive Installation* or in the graphic novel *Mickey on the Danube* published by *Jumătatea Plină*. Berceanu is a member of *dramAcum*, an NGO for the development of new dramaturgy. At present, he is a doctoral student at the *Babes-Bolyai University, Faculty of Theatre*, and his doctoral thesis is on *Violence in Performing Arts, from Hypnotic Power to Social Responsibility*, coordinator PhD *Miruna Runcan*; he is also associate professor at *UNATC IL Caragiale, department of Stage Directing*.

GRIGORE BURLOIU has been a doctoral student at the *Faculty of Electronics-Telecommunications and IT of UPB* since October 2013, where he researches strategies of augmentation of music representations in real time. He went in a research stage at *IRCAM, Paris*, and he drew up a laboratory study programme, for MA level, which he has been coordinating since 2013. It focuses on the development of software for creative fields, with a focus on the music elements, by using languages such as *Supercollider, C++/OpenFrameworks*, and especially *Max/MSP*.

CĂTĂLIN CREȚU: is a composer, researcher in the field of electroacoustic music, audio-video interactivity and multimedia at the *Electroacoustic Music and Multimedia Center of the National University of Music Bucharest*. Since 2012 he is Associate Instructor at the same university. His habilitation (2008) was published in 2015 under the title: "From the sinus sound to the anatomy of shadow. Technological perspectives in new music".

DRAGOȘ CÂRNECI: PhD in psychology, specialized in affective and developmental neurosciences. In 2004, he wrote the first Romanian handbook of developmental neurosciences. He has also published the works *Origin of the mind; From viruses to beliefs* (2013) and *Stresul din mintea noastră și războiul din lumea celulelor* (2014). Starting from 2010, he has been involved in the field of psycho-neuro-immunology, by studying the relationship between cytokines and some brain mechanisms. He is also interested in the development of cognitive training techniques with a role in brain optimization and the prevention of neurodegeneration and he is the author of the first Romanian portal of brain training.

Paradissolution – Ritual Communion within the Spectator- Performer Frame in Parallel

BEATRICE LĂPĂDAT*

Abstract: The aim of this paper is to investigate the performative strategies employed by the authors of *Parallel* (2013), Sinkó Ferenc and Leta Popescu, in order to generate new forms of communication between artists (Lucia Mărneanu and kata-bodoki halmen) and spectators. The relationship between performers and spectators ranges from an initial recoil and fear to full empathy, achieved by means of traumatic narratives as well as through irony, humour and "gender performativity", to use Judith Butler's terminology (Judith Butler, 2006). I constructed my discourse around the hypothesis according to which the communion between spectators and performers can be traced by following the pattern established by Dante Alighieri in his *Divine Comedy*. I view *Parallel* as a journey that can be segmented in three stages, also explored by Dante throughout Hell, Purgatory and Paradise, implying the exposure of a tortured-torturous body, of nudity, a phase of relief and one of what I called "Paradissolution".

Keywords: Parallel, Dante, torture, guilt, empathy, nudity, gender performativity, queer.

Parallel, which premiered at the end of 2013, is a one-hour long performance led by Romanian artists Lucia Mărneanu and kata-bodoki halmen. It is worth being mentioned that both young artists were students at the Faculty of Theatre and Television of the Babeş-Bolyai University in Cluj-Napoca at the time when choreographer Sinkó Ferenc (concept / choreography / direction) and young director Leta Popescu (direction), affiliated to the same institution, shaped the performance. *Parallel* plays not only with space, concepts and objects, but also with the limitations and expectations experienced by spectators. The three main parts of the show permanently challenge the viewers' perspective, employing techniques and dramatic constructions whose origins may be traced in notions such as *gender performativity* (Judith Butler, 2006), *écriture féminine*, a term coined by Hélène Cixous (Bray, 2004), *epistemology*

* Université Laval, Québec, PhD candidate, e-mail: beatrice.lapadat@gmail.com

of the closet (Eva Kosofsky Sedgwick, 1990), but also more recent notions such as *metafeminism* (Green, 2001). The juxtaposition of all these elements creates a dynamic and playful performance capable to question in a pertinent manner the traditional roles assumed by both performers and spectators, despite the fact that the show does not presuppose direct interaction with the public.

But it should be noted that in *Parallel* gender-related games do not emerge solely from a series of highly theoretical concepts extracted from feminist and queer theories. Beyond this layer, there is a supplementary stratum that amplifies the reception of the performance in different directions, exceeding a purely social interpretation. My thesis is that *Parallel* is constructed as a journey of initiation with theological implications being added to the socio-cultural interrogations raised by the performance. The main premise is that the performers place themselves in a much more complex position than that announced through their transgressive, gender-bending disguises. Thus, they invite the spectators to become worshippers to a certain extent, instead of acting simply as passively disturbed agents.

The crucial questions I will address are derived from the intersection of sex and gender, both concepts being traversed by numerous other interfering factors, such as race, religion, corporeal culture and theatrical codes. What makes a body passive and / or active in this purposely confusing context? Whose is the victim's gaze and whose is the predator's gaze? What are the specific theatrical means by which the performers use subversion simultaneously as lack of submission and as a profoundly intimate mode of transfiguration? Are spectators held guilty or are they perceived as allies? Does the end of the performance indicate an act of surrender or an act of reconciliation? What role could the spectator play within the scheme of an unconventional liturgy like *Parallel*?

Through this analysis, I intend to demonstrate that the three main levels of construction in *Parallel* reiterate the Catholic doctrine of Hell, Purgatory and Paradise. Thus, the performers establish a meaningful, manifold connection with the audience.

Spectators: from oppressors to confessors

*There sighs, lamentations and loud wailings
were resounding through the starless air;
wherefore I at the beginning wept for them.
(Dante Alighieri, Inferno, Canto III, 1894)*

As spectators enter the theatre hall where *Parallel* is to take place, the first image they interfere with is the minimalist, monochromatically disposed setting (Valentin Oncu). Nothing is violent, nothing is disturbing. The only

colourful element on stage is represented by the two performers' workout clothes (Gyopár Bocskai): green and blue pants, red and pink tops. Interestingly, the two show up on stage for fitness practice without any footwear item, which marks from the very beginning a deviation from the norms instituted by this type of physical training. Barefoot as they are, the women start their exercises. Far from being agile, determined and conspicuously strong, yet simultaneously full of grace, they are training in a rather correct manner, without falling or stumbling. But there is one obvious fact that brings irony and derision to surface: they don't seem to enjoy it and neither do they manifest the empowering self-confidence and enthusiasm one is expected to experience during such solicitous activities. Their unshaved hair functions from the very beginning as a manifesto against traditional gender expectations, being ready to expose themselves without any artificial improvements that promise feminine beauty by patriarchal standards.

And yet, at the same time, it would be difficult to affirm their intention is undoubtedly ironic at this point, since they truly work hard and manifest a certain willingness to make a step forward in order to build their bodies according to the trainer's lively indications. Sometimes clumsy, but always powerful, with a rather sad expression on their faces, the performers embark on an ambiguous journey.

There is a significant contradiction that is instilled in the spectator as they witness the women's (self-)ironic attempts and which can be translated in the interrogation concerning how reliable this critical gaze the performers cast upon their own selves could be. The performers who bravely choose to expose themselves may not correspond to the physical standards that fitness impinges on them, and yet, they find themselves in the centre of a theatrical space, which they had conquered and can now use as a platform where they are able to voice their struggles and protests by means of both linguistic and corporeal discourse.

What possibility has the spectator got in order to deal with this exposure? Leaving aside the performers' traumatic narrative for a while and focusing more intensely on the spectator, an exploration of the latter's own traumatic history is inevitable. Heterosexuals, bisexuals, lesbians, gays and gender nonconforming persons are all gathered in the same conventionally homogenous group called "audience". They are all forced to face the performers' wounded history to the same degree, whether they share a similar infliction or simply see in the artist's enactment nothing more than an agent of presumably exotic alterity. Even more, one can wonder whether beyond the parodic effect conveyed by their fitness simulation the artists are, in fact, more than capable of fulfilling such a physical task in the exact terms dictated by fitness norms. If they can, but simply

choose not to submit to these standardized rules unquestionably pertaining to a patriarchal schema, to what extent does the spectator feel comfortable to invest them with credibility? If their apparent clumsiness is theatricalized, how can the performers install empathy within the possessors of maybe some even more unfit and untrained bodies? What conclusions can one draw from this *being-in-the-middle* attitude – neither completely subversive, nor completely immersed in the pleasure of physical strength?



Fig. 1: Photo courtesy of Roland Váczi

It is neither possible, nor necessary to speculate upon the traumatic baggage that each individual in the audience may carry. And yet, one cannot overlook the fact that the performers initiate a dangerous process that engenders deleterious effects for both artists and spectators, due to the fact that the latter are forced to plunge into their own chronology of inadequacy and turbulence. But it goes without saying that the confrontation is far from being much easier for the spectators for whom gender issue has never been a *troublemaker*, in Butler's terms (Butler, 2006). On the contrary: the more circumscribable to cisnormativity is one who enters the theatre hall, the more striking is the impact exerted upon him / her, since the understanding of gender roles and sexual identity presumed by a rather traditional spectator is completely shaken, when not subtly ridiculed.

At this point in which the artists express their incapacity to submit to the patriarchal standards prescribed for women in order to gain respect and prestige, spectators are invested with the force of a micro-societal organism. They stand as a symbol for a community that bears guilt for the two women's condition and understand that they must take this guilt upon them in order

to push the confession forward. The merciless exposure performed by the artists can be regarded as an act of confession or as a silent denunciation, but nonetheless as a chance they offer those in the audience to fill the blank space left by their absence from the performers' past. During a 10-minute workout routine, what the performers actually release are years of rejection, denial, self-hatred and inadequacy, but all these have never been seen and *witnessed* by the majority of those who are watching from the theatre hall. Inside this collective composed of two performers and usually around 100 spectators, there are only two entities that are enabled to manifest themselves and to ultimately heal themselves. The public rests silent as the artists not only perform their own mutilated and repressed history, but also deliver a symbolic Last Judgment to whom those in the audience fall as subjects. There is torture, but no forgiveness for any of the humans involved; to put it short, this stage can be simply described as *Hell*, in terms of Catholic spirituality.

Therefore, we can but wonder what may be brought onto the stage in order to link the voiced with the voiceless; the outcasts that had obtained the privilege of coming out into the light with the outcasts that are still captive in a homogenous mass within which concealment represents their daily and unique performance. And how is it possible for a connection to be established between all categories of outcasts and those for whom heteronormativity is deeply inscribed in their corporeal evolution?

In this apparently dynamic and ironically displayed first scene in *Parallel*, guilt is fairly distributed between performers, who are not yet able to transcend the gender expectations induced by androcracy, and spectators. In this phase, in which no expiation for guilt is made available, performers and spectators as well travel through *hell*.

When mystic St. John of the Cross writes about the various stages of initiation into contemplation that involve "grief and torment" and which he names *the dark night of the soul*, he mentions light as an inevitable correlative of darkness. But light, in the given context, is also configured as an element that the individual devoted to contemplation cannot fully grasp or assimilate, because its force is unbearable:

When this Divine light of contemplation assails the soul which is not yet wholly enlightened, it causes spiritual darkness in it; for not only does it overcome it, but likewise it overwhelms it and darkens the act of its natural intelligence. For this reason Saint Dionysus and other mystical theologians call this infused contemplation *a ray of darkness* [our emphasis] – that is to say, for the soul that is not enlightened and purged – for the natural strength of the intellect is transcended and overwhelmed by its great supernatural light. (St. John of the Cross, 1959, 50)

The bodily torment disclosed by the artists at this point of the show is nothing but the physical outburst induced by the torment of the soul, being reminiscent of ritual self-flagellation practices (which are to be fully developed, as I will present further in the paper, in the second part of the show). Thus, their intense physical effort is not a path to beauty and perfection but, from a Catholic perspective, a penance through which they confess their incapacity to be neither pure nor completely rebellious in regard to the standards imposed on them. If the body suffers, if the flesh is cruelly manipulated (in *Parallel*, the saints' punitive rod has been replaced with dumbbells and a jumping rope), then somehow there must be a sign of redemption at the end of the road. In his treaty on penance and self-flagellation addressed to "the Virgins consecrated to God", Saint Alphonsus de Liguori states that

to preserve her soul and body free from stain, she must also chastise her flesh, by fasting, abstinence, by disciplines and other penitential works. And if she has not health or strength to practice such mortifications, she ought at least to bear in peace her infirmities and pains, and to accept cheerfully the contempt and ill-treatment that she receives from others. (Saint Alphonsus de Liguori, 1888)

No liberation is announced at this point either for the performers or for the spectators. Yet, the torment to which the two women subjugate their bodies does not rest without effect: due to their arduous efforts, this homogenous group starts shaping its identity as a community that is now bound up by the shared experience. Thus, the spectators' status as witnesses literally standing on the margins modifies from *testis* – "the position of a third party" (Agamben, 1999, 17) – to *superstes* – "a person who has lived through something, who has experienced an event from beginning to end" (Ibid.).



Fig. 2: Photo courtesy of Roland Váczi

The *infernal* stage cannot be overcome or annihilated, but instead it functions as a necessary bridge that links all bodies taking part in the performance, whether on stage or outside the central platform. The audience, just like the crowd of the moaning souls that Dante mentions in the *Inferno*, had witnessed a torture no one else had and thus this ceremonial secrecy formulates the premises for the prolongation of the journey. Despite the fact that Western imagery is imbued with grotesque depictions of hell, *The Catechism of the Catholic Church* makes a clear statement:

The chief punishment of hell is eternal separation from God, in whom alone man can possess the life and happiness for which he was created and for which he longs. (Catholic Church 1035)

In the first section of *Parallel*, violence is never aggressive and is never based on shock effects; what the performers enact is what we may call an *aseptic exposure*. Physical wounds, bruises, self-harm, body liquids or brutal malformations – none of them finds its place in this repertoire of disturbing, but geometrically designed gestures. Hell may be understood as absence and abandonment in the world, but in *Parallel* it is also constructed as a space which the individuals involved in the communion are invited to fill with the matter of their own flesh.

The spectator's gaze is assimilated by the performers as an apparatus capable of generating new material for the unfolding of the theatrical event. The two artists do not erase the possible contradictions that the spectator may experience, as I signalled above. They do not seem to be particularly interested in creating a highly intimate contact with the spectators upon which they project their own trauma. What they manage to achieve in relation to the viewers is the assumed incorporation of all the contradictions and non-answerable questions, of all the empathic and skeptical gazes, of all the bodies that symbolically precipitate onto the stage, assaulting the exposed subject.

By the end of the first scene, *spectatorship* does not become *worship* yet, but a sense of membership and belonging, even in the midst of *Hell*, is definitely weaved through the assimilation of the meaningful difference emerging from both performers and spectators. As Eugenio Barba puts it:

Offering the spectator the possibility to decipher an event does not mean offering them «the true meaning», but it means to provide them with the necessary questions in order to interrogate their own selves in relation to

the meaning. There are spectators for whom theatre is essential precisely due to the fact that it does not offer them solutions, but intersection points.¹ (Barba, 351, 2010)

The speaking gaze: fire, nudity, twilight

*Look if thou e'er hast any of us seen, /
So that o'er yonder thou bear news of him; /
Ah, why dost thou go on? Ah, why not stay?
(Dante Alighieri, Purgatory, Canto V, 1886)*

In Canto V of Dante's *Purgatory*, the poet is warned by Virgil to keep moving the moment a crowd of wandering souls would address him. Those whom Virgil refers to are individuals that "by violence died", but now repent for their sins. The group heads towards Dante and, as one, they ask him to acknowledge their presence there for those on Earth in case he recognizes any of them. Dante admits he is not able to recognize any of them, "although I gaze into your faces" (Dante 1886), but also ensures them that their confessions are safe with him - "speak ye" - and that he would do whatever depends on him to help them. Each of the souls recounting their tragic stories invests Dante with the power and dignity of a herald who is supposed to accomplish a sacred mission, that is to say, to share the ungraspable for those who had not had the possibility to *witness*. As he complies with the process of witnessing, the poet allows his identity to be infused by the miserable souls' condition. Moreover, his mission as messenger consists in disseminating their status, which can be interpreted as a temporary act of redemption from death for the helpless souls. Gaze, movement and discourse: these are the three steps the reader discovers in Dante's short, but insightful encounter with the repentant dead from the Purgatory.

At this point of the performance, spectators are no longer submitted to the torment of witnessing what they cannot fully understand. The spectator must watch everything in a state of "fear and trembling", but is no longer judged or forced to repeat the traumatic narrative. Instead, now that they had visualized the "othering" experience and also took their share of guilt for the *status quo* narrated by the performers, it is implied that they would not leave the performativity arena unmodified and that their own

¹ Our translation from Eugenio Barba: *Theatre: Solitude, Craft, Revolt*. București: Nemira Publishing House, 2010, p. 351.

bodies and speech will manifest themselves in accordance with the mortifying experience. The spectator's gaze becomes active not in the sense of a visceral recoil or a similarly violent unconditional adherence, but in the sense in which he silently turns his extreme emotions into a vehicle for metamorphosis.

While it is true that the dogma of Purgatory is one of the most challenging dogmas within the corpus of teachings assigned by the Catholic Church – the controversy sparks genuine interest even to this day, still there are a series of clear, indisputable statements in relation to this concept. The decree formulated on Purgatory at The Council of Trent in 1563 reaffirms the Church's undeniable belief in this notion, but nonetheless the members of the Synod of Trent made it clear that "the more difficult and subtle questions (...) be excluded from popular discourses before the uneducated multitude." (Council of Trent, Session 25).

However, approximately one century before the Council of Trent took place, Saint Catherine of Genoa, a 15th century mystic, does not hesitate in depicting the Purgatory as a place that is but in a few aspects differentiated from Paradise. "The joy of souls" comes from their conscientious understanding of their transitory condition, as if they had already viewed and experienced the further heavenly delights that are to come. Fire is not destructive, but rather empowering, since it provides the soul with the necessary understanding of both his sin and of the possibility to be purged:

It is in this way that rust, which is sin, covers souls, and in Purgatory is burnt away by fire; the more it is consumed, the more do the souls respond to God. *Pain however does not lessen, but only the time for which pain is endured* [our emphasis]. (Saint Catherine of Genoa, 1946)

The saint courageously moves on to affirm, in Chapter III, something even more radical in relation to the condition of those in Purgatory:

Because the souls in Purgatory are without the guilt of sin, there is no hindrance between them and God except their *pain* [our emphasis], which holds them back so that they cannot reach perfection. (*Ibid.*)

The second and also the longest part in *Parallel* gives the viewers the possibility to cast a gaze upon this transformation the performers do not seek to hide. The transitional phase alludes to a space and time that involve severe modifications of the body and the soul. As a consequence, it is inferred that the very presence of an alien body in the same space represents a privilege for the latter and an undeniable source of pressure for the exhibitory subjects.

Once their fitness movements are finished, Lucia Mărneanu and katabodoki halmen begin operating a series of alterations upon the space. They strip off their workout clothes and show up in black boxer shorts and tops, with most of the epidermic surface exposed. Soon, they turn their backs to the audience and move to the back of the stage, whereas in the first scene the physical distance between them and spectators was considerably lower. Neither darkness, nor light infuses the theatrical platform integrally, but it is their alternation that disturbingly creates the main visual mark of the set, just as inside Purgatory the soul is extrinsic to the pure light of Paradise, but also remains outside the total obscurity of Hell.

After a short examination of their muscles, they throw their tops and create an initial contact with some of the objects placed on stage. The soccer ball hits the floor and the wall during a sequence of rhythmically destabilizing movements. Music (composed by Daniel Aga, known as danaga) is also constructed as a constant alternation between electronic beats and lyrical tonalities and helps modelate the twists and contortions of the bodies. Whether the performers' choreography is mobilized by the game with the ball or whether they touch the reproduction of Duchamp's famous *Fountain*, the spectator can easily observe that the nature, intensity and duration of their contact with the objects is different under all aspects from the manipulation of the jump rope and dumbbells in the first scene.



Fig. 3: Photo courtesy of Roland Váczi

What their bodies transmit while interfering with the things displayed on stage is a certain willingness to use them not as instruments that serve for self-condemnation or as a pretext to install guilt in the witnesses, but as a mean

of genuinely discovering the other in their own self. The jump rope and the weights consuming their bodies in the previous dramatic episode stand as symbols for strength, but the strength to which they are supposed to lead belongs, in fact, to the realm of femininity and grace. It is not force that counts when the female subject exercises her physical technique – one should never have a real insight on their torment and one should not see how fierce the female subject can be. From a traditional perspective, these are nothing but a series of necessary stages in order to attain beauty, grace and delicacy.

But the tyrannical faciality machine (Deleuze and Guattari, 1980) represented by the unseen fitness coach disappears in the second scene, and thus a new bodily and tactile journey is revealed to the performers. The soccer ball is traditionally associated with male power and with a whole set of phallogentric cultural prescriptions, while the ironic placement of the urinal in the back creates all necessary conditions in order to precipitately conclude that it is the women's penis envy, as Freud would say, that makes them want to inhabit a fundamentally masculine site. But their shift from "womanly" torture to the occupation of a masculine setting is not to be decrypted in terms of denying the feminine and switching to the masculine. Instead, what they actually perform in this scene is an authentic sample of *écriture féminine*, a concept through which feminist theorist Hélène Cixous (Bray, 2004) claims an exclusively feminine space for conceiving, exploring and displaying the woman body. Synthesized in the phrase "woman must write woman", her theory aims at disrupting the masculine syntax and the articulate language that have always dominated both the feminine identity and the discourse related to it:

For Cixous, writing in the feminine is, above all, an attempt to let the other exist without imposing a definition of the self, the writer. *Écriture féminine* is about providing a space for the material and ontological specificity and autonomy of the other to exist, be, shine forth (...) It describes a path towards thought through the body. (Bray, 2004,71)

Thus, during their liberated corporeal investigation that no longer coincides neither with the feminine, nor with the masculine, the two performers access a conceptual terrain that extracts them from the dictatorship imposed by traditional dichotomies. Within their choreographic construction, the soccer ball is no longer redolent of masculine supremacy; on the contrary, it is precisely this clichéd object that serves best at demonstrating the fundamental lack of consistency on which gender and sexuality are based in the societal environment. The persona incorporated by kata bodoki-halmen simulates an urination

act in front of the male urinal after pulling her head inside it and crawling like that on the floor – with a gesture so irony-filled that it would be at least ridiculous to formulate any psychoanalytical assumptions in regard to this almost surrealistic enactment. *L'écriture féminine*, as transposed into body movement by Lucia Mărneanu and kata bodoki-halmen, is an inverted game in which any gender-specific object can be ascribed to any gender, with the implication that their refusal of cisnormative categories opens the door for other marginal sexualities, such as transgender identities, as we shall see in the final part of the present analysis.

By now, the spectator had learnt to anticipate the constant alternation between concealment and exposure, darkness and light, aggression and contemplation. If during the previous sequence it was the performers that had to assimilate and carry in their being the whole set of reactions and energies conveyed by spectators, in the second part it is the latter's turn to engage in a process of filling their selves with the performers' substance. The spectator's *supplementary gaze*, to use a concept borrowed from theorist Peggy Phelan, contributes just as much to the process through which the female-victim body is presented. If spectators want to preserve their body, they must first help preserve the possibly redemptive body of the performer:

Performance uses the performer's body to pose a question about the inability to secure the relation between subjectivity and the body per se; performance uses the body to frame the lack of Being promised by and through the body - that which cannot appear without a *supplement* [our emphasis]. (Peggy Phelan, 1993,150-151)

In this phase, another crucial concept involving theological connotations is nudity, also essential in the performer-spectator paradigm. In his own essay on nudity, Italian philosopher Giorgio Agamben quotes theologian Erik Peterson's article "Theologie des Kleides / Theology of Clothing" (1934). In his paper, Peterson evinces what we may call a chronology of Christian perceptions referring to nudity:

Nudity appears only after sin. Before the Fall, there was an absence of clothing [*Unbekleidetheit*], but this was not yet nudity [*Nacktheit*]. Nudity presupposes the absence of clothing, but it does not coincide with it. The perception of nudity is linked to the spiritual act that the Scriptures define as «the opening of the eyes». (Peterson qtd. in Agamben, 2011, 58-59)

The philosopher then states that this conception can be summarized in a precept according to which "the problem of nudity is, therefore, the problem of human nature in its relationship with grace" (*Ibid.*, 60). In other

words, nudity refers to something else than nakedness when defined in ontological terms, as it articulates a transitional, purgatorial state of being that announces the arrival of grace.

Nudity is also present in Grotowski's essay "The Denuded Actor" (Grotowski, 2014), that focuses on the sense of communion between actors and spectators, though it should be reminded that his conception of nudity is integrally symbolic and metaphorical. Denudation is what transposes the theatrical act from a cultural event to a liturgical celebration and this supreme act is in itself that which brings spectators and performers together in a holy union:

When the actor's body is consumed by fire and is, to some extent, annihilated by its flames (...) the actor offers his body, reiterating the act of redemption and reaching something similar to the state of holiness.² (Grotowski, 2014, 79)



Fig. 4: Photo courtesy of Roland Váczi

Despite the fact that the performers are never fully naked, wearing a piece of black underwear when all other items are left aside, it can be considered that from the philosophical perspective unfolded by the three aforementioned authors all conditions are met for discussing nudity in *Parallel*.

At some point, the spectator takes notice of the unsettling cold light suffused by the light bulb in the back of the stage. Alternatively, the lights

² Our translation from Jerzy Grotowski. *Teatru și ritual. Scrieri esențiale*. București: Nemira Publishing House, 2014, p. 79.

are switched on and off in each of the two areas that divide the performative space. As music becomes increasingly haunting too, a new type of anxiety is now generated inside the spectators' bodies. As I mentioned, they were led towards the anticipation of a specific pattern based on the interaction between passivity and violence. This pattern is now shaken as the two begin executing the manoeuvres by which the light design is reverted and twisted, offering us the hint of a torture chamber. No one can anticipate what may lie ahead of them, as the perspective is open towards all possibilities more than ever in the show up to this moment.

But the gesture performed by kata-bodoki halmen brings to surface a new dimension of spectacular violence, which consequently registers a modification in the performer-spectator equation as well. Silent, sombre and displaying an almost neuter facial expression, the artist interposes a new sound in the scheme, a sound that does not belong to the music of the show. It is the harsh sound of a piece of adhesive tape that she begins to attach slowly around her breasts. The black material now substituting her brassiere is the epitome of mutilation and self-harm in *Parallel*. Immediately afterwards, it is Lucia Mărneanu's turn to repeat the humiliating gesture with a transparent adhesive tape, although she performs it with a certain air of indifference and cold detachment. As in Saint Catherine's records of pain combined with ecstatic voluptuousness, the women on stage never reject the transfiguring potential contained in a moment of absolute affliction.

Nudity is now traversed by its most tragic occurrence: their gesture is a painful de-fetishization of a part of the body that males usually associate with desire and sensuality and a silent confession of their inner mutilation at once. In the terms designated by Agamben (1999), their attempt to cover their breasts in this merciless manner is the articulation of their awareness in relation to God's belatedness in revealing His grace. By covering the skin with an instrument evocative of mutilation in this given context, they actually affirm their complete abandonment in the world. It is not difficult to speculate that spectators had moved from shock to a silent contemplation, which reveals the fact that the connection between them and the performers is now completed and fully consecrated.

However, as we find ourselves at a point I associated with Purgatory, this affliction is soon directed towards a new level. The same way they had previously allowed the spectators to assist their progressive denudation, they now permit them to join in so that they can witness a different process, just as intimate, but much more playful and humorous. Once the process of

denudation is over, the stage partners switch their performance from (self-) aggression to *transgression*.

New objects are brought in order to serve as stage props, objects which seem to announce a celebrative unfolding of events. They cover themselves again and put on their clothes in the mid-stage, staying loyal to their well calculated programme of disclosure-enclosure in relation to how and how much spectators should see. But moving beyond nudity does not put an end to the ceremonial frame. If up to this point spectators had been exposed to the ordeal endured by the feminine stigmatized body, now the spectator is confronted with a new image, albeit their impossibility to set it within a preconfigured category. It is now that we move from the woman body – tortured, victimised, fallen into disgrace and captive between human contempt and God’s silence – to the *all-genders-body*, a process that is to be completed in the third part.

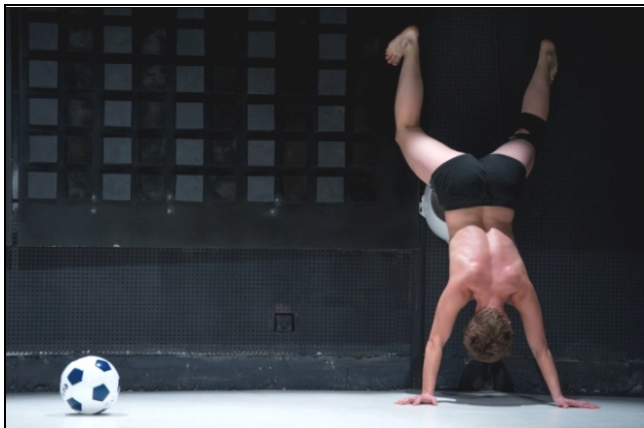

Fig. 5: Photo courtesy of Florin Biolan

The transformative moment corresponds to a notion that is less connected to the above discussed Purgatory, but rather to a concept that preoccupied Jewish scholars and mystics along the centuries. In the Bible, there is a verse in the book of Deuteronomy which states that “There shall not be a man’s apparel on a woman, neither shall a man put on a woman’s clothing, for whoever doeth so is an abomination to Jehovah thy God” (*King James Bible*, Deuteronomy 22.5). Therefore, it is beyond doubt that like all great traditional cultures, Orthodox Jews refuse any gender negotiation – there is no room for experiment or perilous identity games. And yet, in his

2006 conference speech entitled “The Holiness of the Twilight”, Rabbi Reuben Zellman explicitly justifies the legitimacy of transgender identities by referring to ancient Jewish sources. Just as during the 24-hour cycle one encounters not only total dark and intense sunlight, but also innumerable nuances the eyes meet at dusk, so can things be understood in relation to gender:

Our rabbis believed that twilight held great and unique power. (...) Many of them acknowledged that (...) *that middle place between light and dark could never be boxed in* [our emphasis]. It was not day and it was not night. Twilight was something else all its own. (Zellman, 2006, 3)

Supported by their witnesses, confessors and newly-invested priests that had faithfully followed their journey, either voyeuristically or empathically, the two performers escape the pains of Hell and the doubts of the Purgatory, having finally found their own in-between mental and spatial locus, “the twilight of twilights” (ibid.), a place where the outcast is permitted not only to perform, but also to rest.

Dragging the body into the light

*Whether it was the last created part /
of me alone that rose, / O Sovereign Love, /
You know, Whose light it was that lifted me.*
(Dante Alighieri, *Paradise*, Chant I, 1986)

The third and final part of the show coordinated by Sinkó Ferenc and Leta Popescu is constructed on three main interfering levels: *gender performativity* (Butler, 2006) by means of drag culture interventions, linguistic discourse and the rewriting of ritual along with the spectator, as a result of the investigation operated upon gender and sexual identity. Much can and should be said in relation to the gender bending mechanisms the performers operate with, from outfits to their assault upon articulate language, which they indirectly dislocate from the centre of patriarchal syntax. Since not all of the mentioned elements are correlated with the development of the performer-spectator relationship, I shall only make use of those that are relevant to this central issue.

However, the notion of gender performativity is of paramount importance in the evolution of the relationship between spectators and performers, since it gives birth to a new level of empathy now based on humour and irony, in contrast to the previous empathic networks created through pain and marginality. The use of drag-related techniques – with Lucia Mărmeanu as a transvestite and

kata bodoki-halmen as a purportedly ambivalent combination of drag king and drag queen elements – stimulates the enhancement of a new perception that spectators may gain in relation to the performative agents, in that it manifests a humanizing effect. It is no longer *the tortured-torturous body* – that is to say, *martyr-body* – that offers itself to the spectator’s gaze. A new body category is now at the viewer’s disposal and one feels much more comfortable to watch it when it is covered with clothes and, consequently, with several new layers of signification, despite the intended ambiguity of their anti-traditional apparel. In *Gender Trouble. Feminism and the Subversion of Identity*, Butler explains the political and cultural role drag is supposed to play within society in the following terms:

This perpetual displacement constitutes a fluidity of identities that suggests an openness to resignification and recontextualization; parodic proliferation deprives hegemonic culture and its critics of the claim to naturalized or essentialist gender identities. (Butler, 2007, 188)



Fig. 6: Photo courtesy of Adrian Pîclişan

Kata bodoki-halmen’s black leather suit along with the high-heeled shoes connote a form of exoticism she does not fear to exhibit, the same way that her partner’s morphology is radically modified due to the masculine suit she is proudly wearing. The artists reiterate a procedure that had made catharsis effective in the second scene: the only possibility to transcend the cliché placed upon you by society and its amputating constrictions does not consist in avoiding it, but in assimilating and interiorizing it until the nature of the oppressive labelling changes in the opposite direction. The “epistemology of the closet” – to use Eve Kosofsky Sedgwick’s expression – is now exceeded in favour of something much more subversive:

Just so with coming out: it can bring about the revelation of a powerful unknowing *as* unknowing, not as a vacuum or as the blank it can pretend to be, but as a weighty and occupied and consequential epistemological space. (Sedgwick, 1990, 77)

The spectator makes one more step further into performative irony as the artists introduce verbal discourse (to which all participants in the show contributed) – and it is only now that the audience clearly acknowledges, without any allusion or metaphor, the true sexual identity at stake, which is the lesbian identity. This revelation is brought to light with the help of a playful mode of speech, in an attempt to ignore the fact that the language through which we define marginal sexualities pays tribute by its very nature to the same patriarchal structures that are attacked. Therefore, linguistic transgression is aided by the attachment of various other subversive techniques and it is only their combination that produces resistance:

The results of a systematic inquiry into the sexuation of language are still treated with vague suspicion. Is this a reversal, a «return of the repressed», of the mastery over language exercised by one sex? (Irigaray, 1993, 134)

Though Lucy Irigaray's question remains unanswered and probably unanswerable, the strategy of reversing language through specific queer-feminist jokes and language games in *Parallel* ("What is better – to be born gay or black?" "Black, because you don't have to tell your parents"; "What do you call a woman with an opinion?" "Wrong!") activates the most energetic and fully exteriorized reactions that the public had manifested all throughout the show. Spectators reach a point of relief through language – now freed from its androcratically submissive function – and, as one can easily notice, it is far easier for the participants to deal with such essentially dramatic issues by means of queer humour. But laughing in a space outside of Hell and Purgatory is the exclusive privilege of those who had suffered the hardships of ontological annulment and identity distortion together with the artists during the previous scenes.

Turning back to the Dantesque analogy I have made use of in this paper, can it be said that the two performative agents had now carried the spectators to a level comparable to Paradise? If one understands this concept as a definitive enclosing in a sphere that had transcended human misery, the answer is definitely not. If at first they deny and then recreate language on their own *trans-* terms, Lucia Mărneanu and kata bodoki-halmen further fabricate their own paradisiacal space, the disguise of the natural body being part of this mechanism.



Fig. 7: Photo courtesy of Andrei Gîndac

But it is only towards the end of the show that we learn the nature of their personal *Paradise* towards which spectators are lifted too. Once jokes and irony proved their effectiveness in relation to the (usually extremely) sympathetic audience, the spectacular strategy suddenly shifts to confession, this time articulated through both corporeal and linguistic discourse.

The performers' free, gender-crossing and, to use Deleuze and Guattari's expression, "rhizomatic" bodies are now reinstalled in a genealogy they invoke in the last five minutes of the show. A "teleplastic abduction" (Lepecki, 2013) is accomplished, which means that we are finally confronted with the fact that we had seen not only the two bodies during their exposure, but the bodies of their relatives and their dead ancestors alike. Mothers, fathers, aunts, sisters, grandparents are all called into question as the artists revive memories that still inhabit their wounded bodies. Thus, familial origins, puberty ("Witnessing pubic hair growing over soul...breasts, hips"), gender roles within the confines of patriarchal family structures are all discussed, denied and somewhat reaffirmed.

Spectators seem to be transported into a litany as the artists replicate one another in succession, with a noticeable change in tonality that signals the shift from irony to supplication. The haunting polyphony leaves behind all subversive intentions – which has been, under all aspects, successfully acquired – and they also abandon the propensity towards protest and rebellion. Nevertheless, not only does the anti-patriarchal statement remain just as valid, but actually it is now that it fully legitimates the will to reconcile with a God who has been rendered to human beings through labels: Male, Ruler, Sovereign, Judge etc. It is thus particularly interesting to take notice of the

fact that, amongst this multitude of godly attributes, the artists do not attempt to denigrate His quality as Father, which is common and encouraged in most feminist debates that seek liberation from the Father figure archetype (see, for example, Mary Daly³ and Adrienne Rich⁴). On the contrary, they seem to find comfort in the playful ambiguity that puts the earthly, “domestic” father on the same line with the heavenly Father, but Who, despite His magnitude, may be just as deaf and passive. Without denying the imperative of a feminist struggle, it can be said that the performers move on to *meta-feminism*, a term coined by theorist Lori Saint-Martin:

the term *metafeminism* both includes and calls into question; it accompanies feminism, espouses its causes, incorporates it into new forms. It does not imply abandonment of what has come before, but a new form of integration, a way of building on past accomplishments (Saint-Martin qtd. in Green, 2001,104).

All these were already clearly articulated and this is the right time for them to be transcended. The issue at stake is no longer a question of LGBTQIA terminology, but a universal condition which Saint Paul explains in Galatians in the following words when he speaks about the way in which redemption annuls all present functioning binaries: “There is no Jew, nor Greek; there is no bondman, nor freeman; there is no man or female; for ye are all one in Christ Jesus.” (*King James Bible*, Galatians 3.28). The performers approach this state through a process I would call *de-genderation*, which would imply that true transgression is reached when gender no longer needs to even be discussed – a perspective evidently inconceivable in the present socio-political context in which marginal sexual identities struggle to affirm their legitimacy. But *de-genderation*, the process of stripping off all genders, can at least function as a herald of the possibility to truly transcend language, power and societal patterns at some point.

The final speech, which can easily pass for a prayer, has a tragic connotation that the performers do not seek to hide or minimize: “Can a BODY heal of its own SOUL? Can it? Can it?” Gradually, darkness covers the bodies, seemingly displacing them from their performative centrality. Dissolution of language

³ In her book *Beyond God the Father. Toward a Philosophy of Women’s Liberation* (Beacon Press, 1974), Mary Daly critically discusses the image of the Christian God as a tool for masculine power and female submission. Daly’s response revolves around women’s necessity to rediscover their divine nature.

⁴ *Of Woman Born. Motherhood as Experience and Institution* (W.W. Norton & Company, 1986) by Adrienne Rich dismisses “the kingdom of the fathers” (p. 56) which she finds within the Christian system of thought and society as well. She also implies that the mystification of the feminine identity is part of the same androcratic process.

and dissolution of corporeality are finally accomplished, as Lucia Mărneanu articulates the final words in the show: “Father, I live for love.” Paradise – in its traditional, Church-confirmed sense – may remain locked for the outcast and transgressor, but *Paradissolution* can never devoid itself of meaning as long as performative discourse is tangible for artists and spectators as well.



Fig. 8: Photo courtesy of Roland Váczi

References

- AGAMBEN, Giorgio. *Remnants of Auschwitz. The Witness and the Archive*. New York: Zone Books, 1999. Print.
- Nudities*. Stanford, California: Stanford University Press, 2011. Print.
- ALIGHIERI, Dante. *Divine Comedy - Purgatorio*. English translation and notes by Henry Wadsworth Longfellow. Boston: Houghton Mifflin, 1886. Print.
- The Hell of Dante Alighieri*. Edited with translation and notes by Arthur John Butler. New York: Macmillan, 1894. Print.
- The Divine Comedy. Vol. III: Paradise*. Translation and notes by Mark Musa. Penguin Books, 1986. Print.
- BARBA, Eugenio. *Theatre: Solitude, Craft, Revolt*. București: Nemira Publishing House, 2010. Print. (Romanian).
- BRAY, Abigail. *Hélène Cixous. Writing and Sexual Difference*. Hampshire & New York: Palgrave Macmillan, 2004. Print.
- BUTLER, Judith. *Gender Trouble. Feminism and the Subversion of Identity*. New York: Routledge Classics, 2006. Print.
- Catherine of Genoa. *Treatise on Purgatory. The Dialogue*. New York: Sheed and Ward, 1946. Web. 10 May 2015.

- CATHOLIC CHURCH. *Catechism of the Catholic Church*. Vatican: Libreria Editrice Vaticana, 1993. Web. 15 May 2015.
- COUNCIL of TRENT, Session 25, 4 December 1563, Concerning Purgatory, *Decree 1*. Web. 13 May 2015.
- DELEUZE, Gilles, Félix Guattari. *A Thousand Plateaus. Capitalism and Schizophrenia*. Bucharest: Art, 2013. Print. (Romanian).
- GREEN, Mary Jean. *Women & Narrative Identity. Rewriting the Québec National Text*. McGill-Queen's University Press, 2001. Print.
- GROTOWSKI, Jerzy. *Theatre and Ritual. Essential Works*. București: Nemira Publishing House, 2014. Print. (Romanian).
- Holy Bible, The, containing the Old and the New Testaments, King James Version. Print.
- IRIGARAY, Luce. *An Ethics of Sexual Difference*. New York: Cornell University Press, 1984.
- JOHN OF THE CROSS. *Dark Night of the Soul*. New York: Image Books, 1959.
- LEPECKI, André. "Teleplastic Abduction: Subjectivity in the Age of ART, or Delirium for Psychoanalysis: Commentary on Simon's «Spoken Trough Desire»". *Studies in Gender and Sexuality*. 14.4. 2013: 300-308. Print.
- LIGUORI, Alphonsus de. *The True Spouse of Jesus Christ*. New York, Cincinatti and Chicago: Benziger Brothers, 1888. Print.
- PHELAN, Peggy. *Unmarked. The Politics of Performance*. London & New York: Taylor & Francis e-Library, 2005.
- SEDGWICK, Eve Kosofsky. *Epistemology of the Closet*. Berkeley, Los Angeles: University of California Press. 1990. Print.
- SINKÓ Ferenc, Leta Popescu. "Parallel Unedited". Vimeo video. 1:00:31.
<https://vimeo.com/81426188> (password provided by video owner).
- ZELLMAN, Reuben. *The Holiness of Twilight*. San Francisco, California: 2006. *TransTorah*. Web. 1 March 2015.

BEATRICE LĂPĂDAT graduated in 2010 from the Faculty of Letters, University of Bucharest. She is currently a PhD student in literature within the same institution, working on a thesis entitled «Mutilation and violence in the representation of contemporary corporeality», coordinated by Professor Ion Bogdan Lefter. She also begun a PhD program in Theatre, at Université Laval, Québec in 2005. Presently, she signs theatre, dance and performance reviews for publications and cultural platforms such as Cultura, Luceafărul, LiterNet and Art Act Magazine. Her interests in arts consist mainly in social theatre, gender-centred performance and contemporary dance.

From effect to affect: narratives of passivity and modes of participation of the contemporary spectator

ANA PAIS*

Abstract: This article considers how dominant cultural and scientific notions of the body and emotions pervade narratives of a passive spectator in the western theatrical tradition. Two main conceptions of passivity model the idea of spectator in the West: one in Antiquity (passivity as receptivity) and the other in Modernity (passivity as inactivity). Theatre history demonstrates that these conceptions are intertwined with the development of theatre architecture and acting practices and theories set out to produce emotional effects on the spectator. Drawing upon Teresa Brennan's theory of affect transmission, I will be looking at how the gradual enclosure of the stage – culminating in Zola's fourth wall and Wagner's darkened auditorium - and the emphasis on the spectator as the target of theatrical effects is in line with the validity decay of cultural notions of the transmission of affect that lead to a self-contained modern subject, that is, confined to the limits of the body. I will be suggesting that the avant-garde movements in the 20th century and post-dramatic practices reactivate affective a fluid connection between performers and spectators that value affect transmission as vital to live events, both as social process and aesthetic material.

Keywords: Affect, Spectator, Passivity, Participation, Theatre Architecture, Transmission, Emotion, Effect

How does an actor generate emotions on stage? Are they real or fake? Are they a result of inspiration or technique? How does s/he play them to have an effect on the audience? These questions have been key to theoretical debates about the actor's craft in the Western tradition. At the core of this debate lies emotion – medium and mediator of the theatrical experience. Yet, the physical encounter between actors and spectators is culturally determined.

* Research fellow of Centro de Estudos de Teatro da Universidade de Lisboa,
e-mail: anapais2011@gmail.com

Therefore, the labor of the actor can reveal how different historical and cultural moments encapsulate theories of emotion grounded in conceptions of the body and its behavior.

Long before interdisciplinary approaches became current, Joseph Roach published a groundbreaking study in performance studies (1985). In *The Player's Passion*, Roach examined theories of acting from ancient to modern times showing how prevalent scientific notions of the body and emotions of a given historical period infuse theatre making. The emotional effect an actor can produce in the spectator is the central craft of the actor. Changing ideas in acting theories disclose changing notions of how the body works and, consequently, what is required of the actor to master it. Likewise, they also reveal notions of perception, activity and passivity as well as disclose embedded concepts of affect transmission. The theatre is, thus, a privileged site to critically access practices of feeling.

In the past ten years, the neurosciences have inspired a proliferous number of studies aiming at understanding not only the actor's labor but also the experience of the spectator. From a broader analysis of consciousness at various stages and practices in the creative process undertaken by Meyer-Dinkgrafe in *Theatre and Consciousness* (2005), to a more specific study on the intertwined dimensions of cognition, physiology and emotion in the actor's engagement with a role carried out by Rhonda Blair in *The Actor, Image and Action* (2008), amongst others¹, many scholars have lived up to the promise of understanding theatre's mysteries by means of scientific knowledge. In light of cognitive sciences, Bruce McConachie attempts to provide a thorough examination of what happens to the spectator during a performance (2008). Claiming the failure of semiotics to provide a comprehensive terminology to grasp such an experience, *Engaging Audiences* offers interesting insights about attention, perception, imagination and empathy, underlying the spectator's activity as opposed to the passivity of the beholder (cfr. McConachie 2013). Science, however, also reflects a larger cultural and philosophical context that informs ideas of emotion and feelings, passivity and activity as well as notions regarding the transmission of affect. These authors paved the way for recent approaches to performance stressing the advantages of bridging theatre and science to a comprehensive understanding of actor training, performance and spectating foreshadowing a considerable expansion of the field (Kemp 2012; Lutterbie 2014; Shaughnessy 2014).

¹ (for a study on movement and cognition cfr. Delahunta, 2005; Delahunta, S., Barnard, P. and McGregor, W., 2009; for a study about the mask in tragedy cfr. Meineck Peter, 2011, "The Neuroscience of the Tragic Mask." *Arion* 19 (1): 113–158.).

Concurrently, in the past five to eight years there has been an increasing interest in thinking affect in performance and the performance of affect. The significant number of distinguished and emerging scholars engaging with the recent tendencies in Affect Theory in papers or panels at academic conferences (PSi, Performance Philosophy), publications, journal issues (*Theatre Research International*, *Theatre Journal*, *Senses & Society*, for instance) or course offerings is evident (Ridout 2006; 2008; Thompson 2009; Dolan 2005; Hurley 2010; Hurley, Erin e Warner 2012; Welton 2012; Manning 2009; Massumi 2002). This “felt” urgency of understanding performance through the lens of affect is particularly striking as emotions and feelings have traditionally been a major topic in theatre, dance or live performance canons, as Joseph Roach brilliantly demonstrated. Affect theory provides us with conceptual tools that can highlight aspects of the spectatorship that remain unclear. Understanding the influence of audience engagement in the unfolding of the event as both social and aesthetic is crucial to reassessing the function of the spectator’s participation.

What does affect mean? As far as affect theory goes, there is a vast array of definitions of affect, considered in opposition to emotion or feelings, at our disposal. In a deleuzian/spinozist framework, affect is a process of becoming at an impersonal level, therefore, in a continual change and flux that the body actualizes, differing from emotions in as much as they are unqualified or uncategorized forms of experience (Massumi 1995). In terms of a more psychological based approach, affect can be considered as material and concrete things that have an energetic dimension (Brennan 2004) or as a underlying motivational system (Sedgwick, Eve Kosofsky e Frank 1995), biologically anchored and arguably universal. In an effort to clarify the ambiguity of affect in relation to emotion and feeling, particularly in theatre practices, Erin Hurley proposes a definition of affect as that which “happens to us” and “through us” out of our conscious control whereas emotion refers to bodily responses that organize our relational experience in the world (Hurley 2010, 22). Feelings, as cognitive science tends to posit, involve the conscious perception and interpretation of what we feel – emotions and affects. From this brief sample, finding a common definition of affect will probably be an impossible and perhaps irrelevant task. In this article, I will use the concept affect to refer to sensitive charges attached to emotions, thoughts and sensations. This enables us to distinguish affect from emotions and feelings as well as to avoid falling into recurrent dichotomies (conscious/unconscious, body/mind, thought/feeling). As I will further argue, the framework of affect theory, namely, models of affect circulation allow for an in-depth analysis of reciprocity as a focal point of audience engagement, challenging narratives of passivity in spectatorship.

Deeply rooted in the western theatrical tradition, the notion of the passive spectator is a cultural construction that can be traced back to two different moments: Antiquity and Modernity. On the one hand, in the classical tradition passivity regards a state of receptivity. It implies the idea of “suffering” from an emotion (*passio*), to literally endure the influence of emotions that come from the external world. While the actor is meant to impersonate emotions and transmit them, therefore, being in control of those emotions, at least to some extent, the spectator is exposed to emotions. Such acting idea is anchored in the philosophical theory of the rhetoric of the passions, which informs acting theories until the 18th century. On the other hand, Modernity entangles passivity with ideas of inactivity. The spectator is subjected to the representation of emotions performed by the actors; he becomes isolated and detached from the stage. Acting is regarded as a technique of sensibility that masters the body, envisioned to submit the spectator to an impacting experience. Contrary to classical tradition, which is tied up to notions of affect transmission widely accepted at that period and on a body vulnerable to the exterior world, the modern notion of an autonomous subject, built upon a self-contained body that defines one’s identity, clearly shapes the figure of the 20th century spectator. This is the moment when Affect Theory steps in.

In the seminal volume *The Transmission of Affect*, Teresa Brennan claims that cultural notions of affect transmission lost currency with the emergence of a modern autonomous subject. A gradual historical process, initiated in the Enlightenment, generates a notion of an emotionally and psychologically contained individual. As the body becomes the locus where emotions are generated as responses to inner and outer stimuli, it defines the limits of subjectivity in relation to others and to the environment. Consequently, affect transmission no longer holds as a valid understanding of emotion for theatre or science. Interestingly, the evolution of theatre architecture in the West reflects this movement of closure of the subject. From the open-air amphitheater in Antiquity to the darkened auditorium of the end of the 19th century theatre, the stage is progressively enclosed and separated from the audience. If the citizens of the *polis* were allowed to express themselves freely during the *City Dionisya* festivals, in modern auditoriums the audience is seating still in silence and in darkness. Yet, both the historical avant-garde from the early 20th century and the performance art from the 60s/70s have been keen on breaking down aesthetic paradigms – contexts, structures, materials and processes – in order to reactivate a two-way connection with the spectator, putting him/her at the center of the experience. Sharing the legacy of such artistic endeavors, contemporary

practices ignite a space of interaction between a participant spectator and a performer presents himself/herself on stage. This conception of a space of interaction is also entangled in prevalent scientific and cultural concepts.

In this article, I will be suggesting that theatre activates practices of feeling encapsulated in cultural and scientific knowledge about the body and emotions. This will be done in two movements. First, I will be looking at how the gradual enclosure of the stage in the theatrical tradition is in close connection with the validity decay of cultural notions of the transmission of affect, as advanced by Teresa Brennan, considering three pivotal moments in acting theory and spectatorship – antiquity and the rhetoric of passions, 18th century and Diderot's the paradox of the actor, late 19th century with Richard Wagner and Emile Zola. Beginning in the 17th century, this slow process resolves by the end of the 19th century with the modern subject, an autonomous self-contained individual. Zola's naturalist 4th wall (an invisible wall that separates the stage from the audience to represent "life as it is") and Wagner's darkening of the auditorium culminate the process. For this purpose, I will draw a comparative analysis between the historical conceptions of the circulation of affect, as proposed by Teresa Brennan, and the history of stage architecture and acting theories considering the work of emotion and the production of emotional effects. Secondly, I will be pointing at concepts of participation and spaces of interaction in contemporary theatre in the wake of postdramatic theatre, which aim at reactivating a reciprocal movement of affect transmission between actors and spectators regardless of theatrical architecture. Inspired by the work of Joseph Roach, I will be contrasting current scientific notions of perception as action, the mind's plasticity and the interdependent engagement of body and environment with post-dramatic concepts of audience participation to provide a contextual frame for the contemporary spectator.

This is not, however, an essay in theatre history neither am I not a theatre historian. I will be referring to several conventional assumptions in theatre history and quoting extensively the inspiring work of Joseph Roach but this article will probably not add much to theatre history. Rather it will complicate it. My aim is not to problematize those conventions (the actual relation between theories and practices of acting, for instance) but to reassess them through affect theory, namely, through models of affect circulation because they can disclose aspects of affective experience that have been largely neglected in theatre studies. As an elusive phenomenon crucial to impacting the spectator, emotion pervades theories of acting often picking up dominant scientific/cultural conceptions. I am interested in the macro perspective those theories provide to thinking narratives of passivity in the theatre and the role of affect

as social process and aesthetic material. Considering that paradigmatic shifts do not happen overnight, the validity of cultural assumptions is not confined to historical periods of emergence, which is apparent in several theoreticians' texts. The issue, however, is how those texts (and corresponding practices) illuminate the value attributed to affect transmission in the theatre as inherent to the spectator's participation in the theatrical event. In this sense, I will be looking at audience engagement as shaped by scenic space and acting theories through the lens of affect theory, highlighting the performativity of spectator's participation in the theatrical event. My aim is to underline the significant echoes of the cultural process of enclosing subjectivity in a self-contained body in theatre practices and, consequently, to point out the potential political, ethical and aesthetic rebound of theatre in shaping modes of affecting and being affected by others, in short, in challenging modes of being together.

The transmission of affect in the theatre

American philosopher and social theorist Teresa Brennan brought forth a theory that gives a provocative insight into the transmission of affect (2004). Recuperating a philosophical tradition of passions as emotional states that circulate and visit us, Brennan claims that emotions are not (only) ours. Rather, they result from an inter-subjective exchange with the environment and the others. Social in origin, the transmission of affect impacts the biology of the body as, for Brennan, affect is *the physiological shift accompanying a judgment* (2004, 5). Different from emotions (as universal categories) and feelings (as awareness of bodily states), Brennan chooses the term affect to emphasize the imprecise though concrete materiality of felt experience (what happens in/to the body) as well as the energetic dimension it entails (what happens between bodies)². In this text, I will use the term affect to refer to sensitive charges attached to emotions, thoughts or sensations, which enables us not only to distinguish it from emotions and feelings but also to avoid falling into recurrent dichotomies (conscious/unconscious, body/mind).

Contrary to the scientific conceptions of emotions as expressions of a self-contained body, Brennan argues that we are open beings who receive and emit signals socially. Who, claims the author, would deny having felt, at least once, the atmosphere of a room? (Brennan 2004, 1). This is part of our everyday

² Although progressively using affect to refer to negative affects, Brennan admits affect does not differ greatly from emotion.

experience. Using arguments deriving from the philosophical history of emotions, neuroendocrinology experiences on empathy, clinic practice and crowd theory, Brennan claims that we perceive signs through the senses in contact with the others and with the environment. This perception is a form of “living attention” interpreting and connecting bodily knowledge with verbal cognitive processes. We are permeable to affects of others and to the environment because we have the capacity to transmit and receive them. For Brennan, transmission is the social process of projection or introjection of affect that has consequences in the physiology of the body. Entrainment – the alignment of two or more people nervous systems that incites common affective responses at play in neuroendocrinology systems (idem, 52) – is one of most salient mechanisms of transmission in Brennan’s study underlying how one can influence or be influenced in a distance by someone’s emotional states or by charged atmospheres. Just like actors do. Considering affect as a performative force at play in social encounters, I will be arguing that the “magic” of theatre lies in heightening the circulation of affect that emerges from collective processes in the artistic context of a performance.

The implications of this social model of circulation of affect are significant. If biology defines the modern subject’s identity in a positivist approach, collective processes of emotional exchange with others and with environment suggest that borders are unstable. Skin separates the body from the environment whereas the social permeates the way that body feels. The biological limits of the body do not contain our identity. Thus, Brennan’s theory breaks through the limits of the body as the original site of emotions and container of identities, challenging the borders between the social and the biological as well as between the individual and the environment. Likewise, in the theatre, the spectator as a receptive porous body immersed in the environment changes into a silent and inactive figure, separated from the stage, however, subjected to the emotional effects.

According to Brennan, the transmission of affect was a popular notion widely shared by the common sense as well as by philosophers, scientists and physicians, until the 17th century. When the Enlightenment paradigm postulates reason as the only capacity to generate rigorous knowledge, the transmission of affect fails to hold its prominent place. Prompted by the extreme technological developments in the turn of the 19th century, scientific knowledge postulated the biological body as the source of vitality and identity of the human being. Yet, positivist methodology – observation, experimentation and demonstration – was incompatible with the volatile nature of affective and emotional phenomena. It could not be seen through the microscope.

On the contrary, the body's behavior and physiology, namely in what regards the expression of emotions, could be observed. Hence, it becomes the original site of emotional phenomena. Although considered as resulting from cultural and geographic contexts as well as hereditary factors, the body becomes immune to social and affective environments. The transmission of affect, Brennan further sustains, has no valid theoretical ground to stand as much as social acceptance from the moment the body became an exclusively biological determination. Theatrical experience, however, provides evidence of the interplay between the biological, the social and the aesthetic.

Blood, spirits and architecture

Passions, so the ancient named emotions, are passive states. One suffers (*passio*) the action of emotions inflicted onto oneself. The work of the actor is to master the expression of such passions, felt through the body, and transmit them to the audience. Although the etymology of the term conveys the direction of such movement - from inside to outside (*e-moveo*)-, in the classical period emotion had a life of its own. Emotions were wandering entities that temporarily penetrated and transformed one's body and spirit. They did not define one's identity; they paid a visit. Therefore, emotions were envisaged as transmissible. Passions claims receptivity from a physiological and spiritual point of view, as the body is regarded to be permeable to natural environment in connection with the cosmos. According to the system of the rhetoric of the passions that dominated ancient oratory and theatre, the actor and the spectator are receptive to emotional states. The actor transmits and influences the spectator via the impersonation of passions in a distance. He is required to undergo a complete transformation in order to "irradiate" emotions over the bodies of spectators (Roach 1985, 27-8). According to Roman rector Quintiliano, the actor has to invoke images - *visiones* - making them present to his imagination. Inspired by these *visiones*, the actor could then animate his words and display bodily expressions (Quintiliano apud Roach 1985, 24). In fact, the actor more than the spectator is exposed to the dangerous power of emotions, as his body is the channel of transmission.

The rhetoric of the passions is anchored in shared popular and philosophical beliefs prevalent until the Renaissance. According to medical knowledge and superstitions, emotions originate in a precise body action: inspiration. Spirits and gods flutter in thin air and can be physically inspired and embodied, only then expressed or transformed. The philosophical theory

of *pneumatism* explains such beliefs. The *pneuma* is defined as a vital force that animates beings through an exchange with the external world. As spirits that permeate bodies through blood circulation, the *pneuma* can be literally inhaled and exhaled. They circulate from the heart to the rest of the body, hence explaining physiological manifestations (blushing or sighing, for instance) (Roach 1985, 27). *Pneumatism* is influential on Galen, the anatomist whose physiology theories (three varieties of *pneuma* and four humors) will sustain the foundations of medical expertise throughout the Renaissance. Emotions, thus, displayed bodily expressions through the action of gods and spirits in motion.

If emotions travel on air, winds are dangerous too. The amphitheaters' architecture confirms the general suspicion about the contagious and potentially lethal power of emotions. In chapters III to IX of book 5 of the first architecture treaty of Western civilization, Vitruvius presents a set of technical instructions to control and optimize the acoustic of buildings, regarding the location of its construction as well as spatial organization schemes. Theatre should be built in "a site as healthy as possible":

For at the play citizens with their wives and children remain seated in their enjoyment; their bodies motionless with pleasure have the pores opened. On these the breath of the wind falls, and if it comes from marshy districts or other infected quarters, it will pour harmful spirits into the system. (Vitruvius 1931, 263–5).³

These points to basic health care rules as precise criterion for theatre construction. Choosing a location carefully, says Vitruvius, avoids "infection". Aware of the implications of breath and blood circulation in the rhetoric of the passions it is easy to imagine that we could either be physically or spiritually "infected" in the open-air theatre. Protecting bodies from contamination, the architect should contribute to eliminate potential threats hovering the empathic and porous spectator. Abandoning himself to theatrical delight, the spectator is unaware of potential emotional dangers, putting reason on hold, which could, according to Plato, provide neither good decisions nor happiness. Instead, emotional contagion as an effect of *mimesis*, was to be

³ The English translation is more descriptive of the organics of the circulation of emotions (the word choice "spirits" and "system" points to the circulatory system through which emotions invade spectators attending a performance), whereas the Portuguese translation is more poetic. It implies the system (*veins* instead of *pores*; *infusing vapors* instead of *pour / system*), stressing the idea of exposure of the body to delight (Vitruvius, 2006 *Tratado de Arquitectura*. trad. Do I. Lisboa: Instituto Superior Técnico, p. 180).

excluded in the perfect city of *The Republic* (Plato 2000). Vitruvius' treaty indicates a conception of the spectator vulnerable not only to emotional states transmitted by the actors but also to the environment; it implicates a direct connection with the natural and cosmic world under which laws the theatre should be built.

In what regards the transmission of affect in the theatre, the rhetoric of the passions prevails throughout the Renaissance, anchored in Galen's physiology that informs the understanding of emotions as humors, invocations and inspirations. Yet, if such knowledge corresponded to the interconnectedness of bodies and environment illuminated by the Greek and Roman amphitheaters, the shift to indoor representations would radically change it. As theatrical representations presented to the king's courts in Europe gradually moved into royal palaces, exchanges with the environment dramatically diminish. The open semi-circular arena gave rise to an enclosed rectangle where illusions of reality were produced by theatrical architecture and stage machinery. Only in the 18th century, with Diderot, will the work of the actor be considered as a craft on its own right and the transmission of affect slowly loose its validity.

Renaissance and Baroque theatrical innovations gesture towards the slow though enduring process of enclosing scenic space and enforce the consequent separation from the audience. In the Renaissance, the introduction of perspective and the proscenium arch envision the potentialities of mastering illusion in a black box, therefore, commanding the spectator's attention and overall experience. The stage becomes a painting, framed by the proscenium arch (hence, proscenium theatre), a representation of reality by means of the optic effect of depth and volume provided by perspective as long as it is looked at from an ideal frontal point – the prince's seat. Baroque architecture not only strengthened the Renaissance theatrical model, but also reconfigured the place of the spectator. It transformed open galleries into boxes and shaped a normative auditorium disposition to reinforce the increasing hierarchical regulation of theatre attendance and social conduct. The prince's view gave birth to the royal box in the new theatres constructed exclusively for the dramatic arts, since the 17th century, whereas the auditorium becomes a second stage for the display of social hierarchies. The opera, in particular, is the scenery of financial, romantic and social encounters, elected by the emergent bourgeoisie as the privileged site for the confirmation of its power.

Diderot and the paradox of (in)sensibility

Scientific developments in physics and physiology during the 17th century fuel the conditions for shifting acting paradigms, in the 18th century: from rhetoric to technique, from expressing to representing emotions, from transmitting affects to producing effects. This change is rooted in new conceptions of the world and the human body. In the wake of Newton's theory, the Universe is conceived as a mechanical system made of equally important pieces – celestial and terrestrial bodies –, which are subjected to the same laws of physics. Small machines within the big machine, all pieces are vital to keep the moving mechanism running. Needless to say, in this context, the concept of the human body as a machine became popular amongst philosophers and scientists who wanted to solve the puzzle: how to explain bodily expression of emotions in relation to the soul that animates it? Descartes' dualist doctrine, the prevailing philosophical and scientific premise in the West until very recently, postulates Reason (the Soul) is like a ghost that governs the body. The body-mind split promotes a move towards the internalization of emotion. The passions of the soul are conceived as an activity of the mind manifested in the body, a machine whose nervous system works in many ways similarly to electricity phenomena or acoustic vibrations (Roach 1985, 94). On the contrary, the doctrine of sensibility offers an account of the physiology of emotion rooted in the body as a mechanism gifted a vital energy. This immanent proposition suggests a crucial turn from a body as a membrane exposed to the environment to a body as an instrument to representing passions. The body of the actor is re-shaped as a machine ready to be trained and mastered.

Scientific theories were deeply influential in Denis Diderot's thought, providing the theoretical ground for the first great treaty on acting: *The paradox of the actor* (written in 1773, published in 1830). Editor-in-chief of the monumental project *Encyclopédie*, Diderot was the most erudite philosopher of his time. As Roach reminds us, without the physiological knowledge he devoted himself to, he would not have approached the work of the actor as a technique (Roach 1985, 117–8). For instance, the principle of dual consciousness requires the capacity of detaching mental experience from bodily manifestation of the character's emotions. Diderot advances the first physiological explanation of such capacity. The actor's mental force (reason) controls the body-machine while observing it at the same time. This conception is only possible when the nervous system is considered as a vibrating instrument – nerves are strings that vibrate – and the organs of the body thought of as autonomous

in its functioning. Like inner organs, the strings of sensibility can be activated separately, as the mind can choose what vibration to observe and reflect upon (*idem*, 148). For Diderot, the fundamental issue was discovering the mechanisms of sensibility, defined as a foundational faculty of the body to respond to stimuli, in order to master them. Here lies the secret of the perfect actor.

The more the actor knew the body's physiological processes, the better could he play the instrument. Thus, the actor's technical competence demands mastering bodily manifestations of emotions, which s/he generates in his mind and imagination, activating his nervous system. Such skills enable sudden changes in emotional expressions without affecting the actor himself. Legendary British actor David Garrick, a model of perfection for Diderot and many other of his contemporaries, was famous for excelling at these emotional shifts. But, what exactly is the paradox?

Il me faut dans cet homme un spectateur froid et tranquille; j'en exige, par conséquent, de la pénétration et nulle sensibilité, l'art de tout imiter, ou ce qui revient ou même, un égale aptitude à toutes sortes de caractères et rôles. (Diderot 1996, 1830)

The paradox of the actor lies on Diderot's claim that representing emotions demands the complete absence of natural sensibility of the actor to feel them. The better he mastered his vibrating system, the less vulnerable he would be to accidental disruption. Only if the actor is impervious in life will he be able to generate the widest range of emotions on stage. Unlike the rhetoric of the passions, this new approach to acting introduces the question of representing emotions as a technique. Not surprisingly, acting treatises depicting images of facial expressions and bodily postures have proliferated since the 17th century (Roach 1985, 71). According to Diderot, the actor must study the physiological mechanisms of emotions in order to reproduce them on stage. He is supposed to imagine the character's ideal model in his mind to guide his interpretation, which implicates reproducing bodily expressions as emotional correlates of inner soul states, without feeling them. This theory is revolutionary for it creates the possibility of emotional mechanisms becoming automatic through repetition in rehearsals. As a consequence, highly artificial representations produce a powerful illusion of spontaneity, or it is perceived as such: the actor's thoughts and emotions become "second nature", in the words of Russian director Stanislavsky, who drew his actor training upon Diderot's premises.

To 17th and 18th century knowledge, sensibility works like vibrations and electricity. The latter inspired a prolific wave of theatrical metaphors, still echoing today. The vocabulary to describe the transmission of affect in the theatre is contaminated with the semantics of electricity. Energy, for instance, acquires a new meaning in the 18th century as a physical phenomenon; a natural force that surrounds bodies and can be channeled (idem, 102). Accordingly, the actor with a sparkle is able to profoundly impact on the spectator due to the mental force fueling his interpretation. Like an electrical shot, the actor projects emotions onto the spectator, “inflaming” him/her hearts (ibidem). In spite of representing emotions, actors still diffused their magic in a distance. Transmission was not yet unreasonable. Like electricity, magnetism provided powerful images to describe the presence of the actor, exerting an inexplicable attraction to audiences who sat more and more in a distance. Jane Goodall suggests that scientific infused metaphors are not totally magic or mysticism free, in the sense that they could not fully describe live performance phenomena but they were useful to cover up for institutional anxieties about contagion (Goodall 2008, 66). Reason could not objectively explain the emotional power of the actor over the increasingly wider auditoriums. Social transmission of affect was to be eradicated as a phenomenon because it was not coherent with an enlightened rationality, committed to dissect, experiment and prove all kinds of behavior and interaction with the world.

Technologies of separation

In modernity, issues of attention are closely connected to reconfigurations of the autonomy of the subject and social separation. Jonathan Crary outlines a genealogy of attention showing how its modern conception is indebted to new technologies, inventions and practices of watching and creating spectacle (Crary 1999, 2). It is not just a physiological phenomenon. Social and epistemological discourses and practices define the 19th century as a pivotal moment in western history, foreshadowing a conception of the subject separated from the world. At the core of these issues are strategies of isolation, deprived the subject from his power of action in the world. Through the manipulation of attention, these strategies shape, frame and control the subject. They are “technologies of separation” (idem, 74), which have far-reaching consequences to theatre making.

By the end of the 19th century, one main technology of separation emerges in the theatre in tune with the autonomy of modern subjectivity: the darkening of the auditorium, which perfected control of light and

illusion on stage, is implemented as the theatre norm. In addition, the naturalist concept of the 4th Wall reinforces the divide between “life” represented on stage and the observing audience. These innovations culminate the lengthy process of enclosure of scenic space that ensures the separation of stage and auditorium, therefore, the spectator’s passivity seating in the dark. As suggested before, the stage gradual confinement mirrors the modern subject’s self-containment insofar as the physical body now restrains emotions and the transmission of affect is definitely erased from scientific and philosophical discourses.

Wagner undertook pioneering reforms at the *Festspielhaus* theatre, in Bayreuth (1876), to create the necessary conditions for a “total artwork” (*Gesamtkunstwerk*). Integrating all the arts through dramatic representation, the “total artwork” requires the spectator’s total surrender. Technical innovations apply scientific improvements in manipulating the body’s physiology to foster a unified perception. Illusion should be flawless, therefore, the stage had to be detached from the auditorium. The Renaissance picture becomes a movie screen (Schivelbusch 1988, 220). Wagner reinforces the proscenium by adding a second arch, which furthered away the audience’s focal point, and sinks the orchestra pit, concealing the sound source to underline its spectral ambivalence. Wagner called this spatial interval that separated real world from ideal world the “mystic gulf” (Wagner apud Collier 1988, 32). Only distance could create the opposite effect: the spectator should abandon himself/herself entirely to the illusion on stage. This technology originates, thus, a separated spectator, deprived of action and disconnected from social and affective environment in the theatre.

This is the matrix of the modern spectator who “lives and breathes the work of art only”, forgetting that he is completely vulnerable at the theatre (Wagner apud Packer, Randall e Jordan 2002, 5–6). Moreover, the spectator must forget his body. When s/he is overwhelmed by the “vapors” of an ideal world, s/he engages in a transformative experience:

His seat once taken, he finds himself in an actual *theatron*, i.e., a room made ready for no other purpose than his looking in, and that for looking straight in front of him. Between him and the picture to be looked at there is nothing plainly visible, merely a floating atmosphere of distance, resulting from the architectural adjustment of the two proscenia; whereby the scene is removed as it were to the unapproachable world of dreams, while the spectral music sounding from the “mystic gulf”, like vapors rising from the holy womb of Gaia (...) (Wagner apud Collier 1988, 32–3)

Wagner envisioned a neutral auditorium, clean of adornments and signs of social hierarchies. On the one hand, he created a democratic space that granted good visibility from all seats equally and faded class privileges. Inseparable from a social cohesion program (cfr. Crary 1999, 247–8), a sense of social community in the audience grew at the cost of eradicating social distractions during the performance. On the other hand, Wagner realized that a full immersion in a dream-like world required complete concentration. He prohibited interruptions from the audience, such as applauding after an aria or the first entrance of the leading singer (Collier 1988, 33). Democratic auditoriums, thus, were not liberated social spaces but limiting containers. As a technology of separation, the total work of art aimed at utterly manipulating the attention of the spectator not at liberating it. The “4th Wall” would seal the actor to the stage.

The “total artwork” is contemporary to the crisis of illusionist theatre, to which the contrasting aesthetics of Symbolism and Naturalism responded. The first created barely human parabolic phantasmagoria; the second pushes illusion to the extreme of representing life “as it is”. Both movements anchor their aesthetic projects in Wagner’s widespread technology of separation to control the attention of the audience. Naturalism deepens the great divide between stage and auditorium by implementing the “4th Wall”, transforming the spectator into a passive witness set radically apart from the empowered actors. The 4th Wall is a theatrical convention that establishes an invisible wall – something imagined like a glass soundproof wall – between stage and audience, closing up the stage entirely. It assumes an absorbed acting style: actors pretending not only they are living (not representing) their roles but also not to notice there is an audience in front of them. The telling images of an audience watching the play as if looking through the keyhole and the actor performing a “slice of life” were popular at the time (Bablet 1977, 18). Theatre is a new laboratory for observing social behavior. A wall divides the space of light from the space of darkness, the space of action from the space of idleness, the space of power from the space of subjection. Fundamentally incompatible with notions of the transmission of affect, the modern subjectivity of the “observer” shapes, thus, the condition of the spectator as a *voyeur*.

Emile Zola endeavored to transform the dramatic arts in light of the scientific spirit of his time. Unequivocally, a positivist foundation crops up in the principles of naturalist representation: only scientific (observation, measurement and demonstration) could provide accurate knowledge of human behavior. What theatre could offer were replicas of the material and social scenarios of conduct. In *Le Naturalisme au théâtre*, Zola claims such a

stunning goal suggesting thorough reformations in theatrical conventions (text, costumes, acting or scenography). The author urged to portraying the “physiological man” (instead of the “metaphysical man”) for his mechanisms and systems can now be measured and tested as well as his hereditary and environmental conditionings (Zola 1923, 124, *passim*). Therefore, if the actor wants to represent life in all its simplicity and veracity, the new actor must study it. Truth was the new essence of theatre and scenography was crucial to display a realistic set that would not compromise the rigor of the experiment. The stage becomes, thus, a test tube to reproduce social behavior objectively, allowing for audience critical examination of moral and ethical implications of such behavior within the matching social environment. Distance was crucial to such verification.

At the Moscow Art Theatre, Stanislavski drew the most influential acting theory and method (“the method”, as it became known) of the 20th century upon similar physiological premises and principles of truth. Russian actor and director reinforced notions of authenticity and believing as fundamental to realistic representations. To interpret a character the actor has to “live” the role, not letting it affect him/her. For Stanislavski, the actor’s “emotion memory” was a crucial tool to fabricate truthful actions on stage, therefore, an illusion of real life experienced spontaneously on stage. Amongst other technical trainings, the actor should listen to emotional resonances of his/her personal experience (life situations of feelings) where he could anchor both psychological and bodily triggers to play his part with repeated brilliance. Following the legacy of Diderot’s paradoxical actor, Stanislavsky develops a method to which invocation of emotion memories and repetition of physical actions is key. The body’s memory can either be prompted to make emotions resurface as bodily responses or, conversely, archive these bodily responses as emotional triggers. Training the body meant training emotion response and vice-versa.

Although at first this might remind us of Freud’s theories of the unconscious, Roach reminds us that Stanislavsky’s system is directly influenced by his contemporary’s psychophysiological theories: Pavlov (Roach 1985, 205). Reflexes are understood as a mechanism of adaptation of the body. Pavlov demonstrated that at the base of reflex behavior lie deep connections between the mind and the body that can be conditioned through repetition. Stanislavsky sets the task of mastering and manipulating these mechanisms for the actor to build a character. Conditioning body reflexes make real the possibility of an encompassing “lived through” rhythm that sustains a complete illusion of spontaneity. In Stanislavsky’s words: “Habit creates second nature, which is a second reality.” (Stanislavski apud Roach 1985, 213)

Inside the body lie the mechanisms to generate emotions. In the method, the actor can devise guidelines for his character behavior, an inner model automatized by the body through the improvisation of physical actions. If each action has a correlate to a psychic and emotional state, this method allows the actor to use his body to reach/induce and reproduce them. Stanislavsky's ultimate goal was the reproduction of "the inner life of the character he is portraying". This phrasing gives us a clear picture of the modern self-contained subjectivity: emotions are of the body and lived in the body as our own, therefore, impermeable to flowing affects. Needless to say, such notion is anchored in modern theories of emotion. Darwin's groundbreaking theory paved the way for the long-standing 20th conceptions of emotion confined to the human body and psyche: William James's definition of emotions as perceptions of bodily states, subsequently processed by the conscious mind and Freud's theory of the unconscious, the mental space where emotions emerge as energy to be expressed/ experienced by the body. This framework provides an idea of emotions in direct connection bodily perceptions and psychic energy; therefore, the body outlines identity.

Reenacting the transmission of affect in contemporary practices

In a highly provocative fashion, the avant-garde movements of the beginning of the 20th century and the emergence of Performance Art in the 60s/70s break with aesthetic conventions and pull down invisible walls. Modernism challenges ideas of context, authorship and materials in a strong critique of representation deeply entangled with political commitment. In the theatre, dramatic texts compromised narrative and character identification (*Ubu Roi*, by Alfred Jarry, for egg.), new concepts of scenic space reorganized the relation with the audience (the Bauhaus, for egg.) and acting techniques thrived (Meyerhold's biomechanics, for egg.). The blurring of borders was the order of the day. Not only artists believed aesthetic paradigms were stale but also were they defective in light of art foreseen in fluid interconnection with life. Theatre's 4th wall was the epitome of separation and power discourses; hence, the perfect target for avant-gardist fierce attacks. Both as an aesthetic and political response to passivity, the avant-garde aimed at overcoming the gap between stage and audience by directly provoking the spectator in the theatre or by literally finding for new audiences outside the building. Futurist *Serate* and variety theatre, as well as Dadaist and Surrealist cabarets, staged outrageous battlefields to provoke the bourgeois spectator. If s/he

was asleep in his seat, delighted with theatrical effects, the avant-garde sought to wake him/her up to the political intervention of art in building a new society. It was a declaration of war to the modern notion of passivity.

Particularly in the US, Japan and Europe, Performance Art disruptive format boomed in the 60s/70s from the provocative legacies from modernist actions. This is the most influential moment for the upcoming generations. Performance Art is an “unmatrixed” genre, as Michael Kirby coined it (Kirby 1965, 21). It does neither create nor function within the conventional matrixes of time, place and character of the theatre. Performance Art does not refer to fictional time or place; it does not represent characters; it does not tell us a story. As the term “unmatrixed” suggests, the borders of this new territory are blurry for its main purpose was to transgress artistic conventions, pushing its material and contextual boundaries to the edge, and to engage in a transformative experience unmediated by representation⁴.

The body and the audience are at the center of inquiry of these self-reflexive practices. On the one hand, performance artists explored the body to question issues of identity – individual, social, gender, ethnic and political. It became a tool, a canvas, and a medium of expression producing a specific kind of knowledge that unfolded layers of cultural and social constructions. The body has a language of its own (Vergine 2000). Allowing for it to resurface, improvisation techniques became a popular method to a critical and self-reflexive approach to determinist conceptions of the body. Performance undermines the perfect match between biology and identity. On the other hand, performances were carefully conceived in order to involve the spectator in the action, including him as a collaborator, sometimes even as a co-creator. The emphasis on the actual shared moment and space, the “here and now” of performance as opposed to theatrical ontological separation, produced a radical change in audience engagement as well as reactivated notions of affective transmission.

Participatory strategies were a means of dismissing the audience entirely, which, according to Allan Kaprow, the inventor of the happenings, was mandatory to eradicate the last traits of theatrical convention of live performance. As early as 1966, Kaprow announced: “the audience must be eliminated completely” (Kaprow 1966, 195). No audience meant, of course, having no observers. Kaprow called for participants in his happenings, rather than spectators, to accomplish the fusion of art and life to create meaningful

⁴ For a retrospective mapping of Performance Art’s main features and developments cfr. (FÉRAL, 1992)

experiences through art works. Yet, what happens when representation is cast out from the stage? What happens when the actor presents himself/herself on stage instead of representing a character? What happens when the spectator is encouraged to participate in the action directly, self-conscious of his role in the event?

Participating, interacting, (re) activating affect

Let's have a break and remember the last time you were at the theatre. Remember what kind of performance you've attended. Were you sitting in the auditorium or were you asked to ramble your way in the piece? Was the performance even in a theatre building? Were you in doubt whether performers were representing a character or "being themselves"? Were you unsure whether some things were part of the show or not? Were actors addressing the audience directly? Did they invite you to join them? Each of you will have different memories according to your taste and experience as theatregoers. However, none of these options will seem unlikely to you. The reason for this lies in the multiplicity of conventions and aesthetics that co-exist in contemporary performing practices. From a Broadway show to an underground performance, one can enjoy an array of theatre architectures, acting styles and spectator's roles. Distinctively of our times is the widening of a blurry area where the historical association between spatial organization and notions of affect transmission is not a direct one. I shall briefly draw your attention to how ideas of participation and interaction are engrained in contemporary theatre practices.

Performance Art reopens a contact zone between audience and performers that radically influences notions of acting, spectatorship and affect transmission. The contemporary actor often presents himself onstage as "himself", aiming at being present in the "here and now" of the theatrical situation. For that purpose, he focuses on performing assigned tasks in the most rigorous way possible and in making decisions on the spot. Renowned American company Wooster Group has been making performances anchored in "scenic personae" or the personal display of the actor as himself on stage since 1975 (Auslander 2002, 307). They emerge during the rehearsal process both from the tasks or activities performed and from the specific actors involved in the work. Instead of representing actions on stage, usually in the context of a dramatic storyline, the contemporary actor aims at performing actions purposefully as possible but without a narrative. Such a tiny detail makes a huge difference in the style of acting. Willem Dafoe, a longtime collaborator, has a scenic persona that

emerges and evolves in rehearsals. He acts himself out, stretching the borders of reality and fiction. When performing with the Wooster Group, what mattered to him was not the interpretation of a role but “reenacting decisions” that came through the creative process. In his own words: “it’s about being it and doing it” (Auslander 2002, 308–9). Spontaneity resurfaces here not as a goal in itself but rather as a result of a task-based aesthetics, which welcomes and incorporates accidental events or individual states of mind (and states of heart). This kind of theatre produces a self-conscious spectator. In the midst of a playful ambivalence the audience has to make decisions: is it real or fictional?

Ambiguity is key to post-dramatic theatre. German theoretician Hans Thies-Lehmann famously coined as post-dramatic practices that take up performance art strategies to disrupt theatrical categories as well as the status of the spectator (Lehmann 2006). Post-dramatic theatre creates a territory of autonomy and responsibility for the spectator in which decision-making processes rise as the corollary of a critical ambiguity. The term refers to a set of operations of deconstruction, fragmentation and juxtaposition undertaken by those practices, not to a moment “after” dramatic text. Lehmann argues that drama is present in this kind of performances because it challenges its structures and categories while dislocating text as a working material from its traditional logocentric site. Post-dramatic theatre shatters fundamental categories of Aristotelian drama – time, place, text, characters, action – giving rise to self-reflexive performances engaged in questioning issues of representation, audience engagement and theatrical apparatus. Strategies such as repetition, expansion, fragmentation or simultaneous actions reconfigured expressive qualities of materials and creative processes. For instance, time is no longer referring to dramatic action but promoting an experience in itself. As durational performances by Marina Abramovic or the UK based Company Forced Entertainment exemplary demonstrate, the passing of time is crucial to the aesthetic experience of these artists’ work⁵. Contracting time in repetitive sequences or expanding it into unthinkable periods, they push temporal limits of live performance.

Let us take one of Forced Entertainment’s most famous show – *Quizoola!* (1996). For 6 hours, two performers share the stage – an area depicted by light bulbs on the floor. They endure a monumental quiz of 2000 scripted

⁵ Marina Abramovic longest performance is *The Artist is present* (2010). In this retrospective exhibition at the MoMA (NY), Abramovic sat on a chair at the ground-floor entry hall for three months during the museum opening hours as people lined up to sit opposite to her. Forced Entertainment shows can last from 2 to 24 hours.

questions answering them in turns of improvisation while the audience is free to come in and out of the room. Issues range from the personal to the political, from philosophy to everyday, from funny to harsh and the spectator can never be sure if questions are addressed to the performer or to his "scenic persona", therefore, s/he can never be sure if they are answered according to the former's biography or beliefs or rather to those of the latter. Although they will answer in the first person, the spectator has no clue whatsoever about who is the speaking subject or what is real or fictional. Likewise, there is no point in looking for true or fake emotions. The contrast between the performer's blurred clown make up faces and their everyday clothes signal the prevalent contradiction that challenges audience responses. Spectators are addressed only through visual contact. Yet, they are part of space of interaction as their thoughts, internal answering of questions, emotional or memory associations and laughter (which is quite expected in this show) influence the atmosphere in the room and the tone of *complicité* conveyed by the performers to the audience. Unlike the realist absorbed acting, post-dramatic performers acknowledge the audience. If a spectator sneezes, the actor may react to it. S/he is receptive to the unpredictability of the moment and plays with it. S/he makes explicit his awareness of the audience, which, in turn, makes the audience self-conscious about being at the theatre. It also puts the audience in an ambiguous place, in the midst of playful ambivalence between fiction and reality, compelling the spectator to make decisions.

Rather than watching a structured sequence of events, the spectator is confronted with unclear situations, enigmatic characters and simultaneous actions that force him/her to make decisions. S/he is granted a new autonomy and responsibility. Seated or wondering about in a space, the post-dramatic spectator makes choices about the performance: whatever he will be paying attention to will depict his/her own performance. Dialogue shifts from a conversation within the stage to a conversation between performers and audience. As Lehmann reminds us, the reality of theatrical situations happens between stage and audience, thus, in a space of interaction. While the actor focuses his attention on the "here and now" of the situation, the audience responds with mental and emotional reactions, thereby participating in what actually happens (Lehmann 2006, 136).

Can we unpack underlying propositions at stake in contemporary conceptions interaction and participation? The first seems to be rooted in the notion of the body as interdependent and co-constituted by the environment in a continual process; the second implies a notion of perception as action or simulated action, a cognitive and sensorial mapping of the territory in real

time. Both notions resonate with recent neuroscience findings about the plasticity of the brain and studies of emotions as neural functions that reposition the debate on mutual influence and interdependency⁶.

Not only were the 60s/70s fraught in art experiments, but also in philosophical paradigms and critical theory. Post structuralism initiated a fraught critique of the subject's Cartesian model emphasizing the complexity of cultural factors involved in human experience and power discourses that pre-determine it. As the idea of an embodied mind gained popularity, both in the humanities and in science, the emphasis on a two-way connection and influence with the environment changed the conceptions of behavior. The body arose as a nodal point of a complex circulation of information – neural, emotional, psychic, and cultural – rather than the site of origin of such engagement with the outer world. Neuroscience studies on perception helped disseminating this new conception.

Perception has been reassessed as a cognitive and sensorial activity, reconfiguring notions of passivity traditional attributed to bodily perceptions. Instead of a passive receptacle of stimuli from the environment, the body is currently conceived as taking part in a co-evolving process with the environment. Thus, perception emerges as a multisensory interaction with the outer world. This approach benefits from the groundbreaking discovery of mirror-neurons by Rizzolati and Gallese, in 1996. Providing striking evidence that the same neurons fire whether we perform an action or when we see someone else performing it, this research points to the inherent activity of perception. In tandem with the discovery of brain's plasticity – the brain's capacity for changing neural pathways as a consequence of behavior and experience, and vice-versa –, these findings shake formerly credited assumptions of body-mind, active-passive, emotional-neural dichotomies.

From a neural point of view, there is no difference between doing and observing an action, as perception receives and interprets information. Conversely, from a bodily point of view, there is no difference between a true or false neural mapping as it is always an experience happening in the body. Hence, in contemporary post-dramatic theatre the blurring of borders between reality and fiction, true or false, theatricality and performativity in a space of

⁶ Although theory and practice dialogues, in particular with science, have been the touchstone of contemporary experiences in the arts for the last twenty years, I am not implying that there is a direct influence between neuroscience and theatrical conceptions. The aim here is to flag the possibility of recognizing an underlying, perhaps not purposeful, syntonetic attunement between conceptual premises in performance and science.

interaction echoes the intrinsic dynamics of doing and perceiving, in the body and in the mind. It is as if post-dramatic actors interweave truth and falseness, acting and observing while performing in the same fashion that the brain molds and is molded by experience. Contrary to extracting a second nature from automatic repetition of actions according to a model of perfection and separation, the post-dramatic actor plays with boundaries of reality and fiction in order to be in the present, displace representation and incorporate the spectator in an ambiguous territory of multiple interactions.

This is also related to current notions of perception as modes of action. Alain Berthoz and Alva Nöe are two stimulating authors to mention here because their research highlights decision-making and bodily knowledge as activities. Berthoz postulates that perception is a simulated action in the brain that involves a judgment and decision (Berthoz 1997, 15). Bearing a proactive conception of the brain, that is, considering that the brain can analyze and evaluate context coherently, Berthoz proposes a sense of movement to explain how we anticipate the consequences of actions. This extra sense, Berthoz sustains, is responsible for internal simulations that capture global configurations of gestures and events, preparing us for acting upon the world. Perception, thus, collects and interprets various sources of information. This speaks to Nöe 's approach of perception as an active competence of the body.

Alva Nöe maintains that sensorimotor bodily processes are at the core of perception. Reacting to neurobiological theories that focus on brain phenomena, Nöe lays the emphasis on the senses and on bodily experience as what provides the intrinsic ability to perceive. The author claims that perception is a mode of knowledge both sensorial and conceptual because, not only the body mediates our experience but also can it be reflected upon. Nöe suggests that perception is a mode of acting and thinking anchored in bodily experience (Nöe 2004, 3). Acting and thinking, he further suggests, are forms of knowledge identical in kind though distinct in degree of connection / engagement with the world that happens through the movement of life⁷.

It makes sense to envision the contemporary spectator as a participant in a space of interaction through a perception of movement (and its effects on the body) that activates potential action in the theatrical situation. In 1974, Marina Abramovic confronted the audience with the possibility of doing anything

⁷ These concepts greatly resonate with the work of theatre scholar Josette Féral on reception and on the "performative actor" (2008). Putting an emphasis on the activity of contemporary theatre rather than on its relation to drama - as in Lehmann's concept of the post-dramatic - Féral highlights the performative aspects of new practices. Although to my knowledge this contribution to theatre theory is not translated into English, I find it worth mentioning.

they wanted with objects laying on a table, from a bullet and a gun to a feather. *Rhythm 0* is a radical example of a challenge to the spectator's simulated action for it can actually result in political and ethical definite decisions, especially to the artist herself. Artistic situations like this prompt the audience to process information coming from various sources, which demands both acting and thinking. They start making decisions with their bodies at the same time (or before) the meaning of their decisions and of the experience itself arises. Whatever they decide will have consequences on the unfolding of the performance, whether or not they take directly part in the situation. Thus, ideas of participation in post-dramatic theatre are in tune with an "enactive approach" of perception as a way of processing, interpreting and dealing with the environment through sensorial contact. Participation is acting and thinking in the contact zone of the performance.

In addition, from the moment emotions are researched as biological functions of the nervous system, that is, as functions of the brain, we cannot consider them neither as mere physiological states nor through a reductionist stimuli-response logic (Ledoux 1996, 12). Contrary to previous paradigms, neuroscience and neurobiology approach emotions with a conception of the brain deeply entangled with bodily states, a brain that works as translator between sensorial knowledge, felt emotions and consciousness. It develops neural patterns for emotions to travel; conversely, emotions interfere with and change neural patterns. Contrary to previous views, the brain changes throughout a person's life. Dominant concept in science and the humanities, plasticity is the capacity of the brain to change and adapt to context through experience.

According to French philosopher Catherine Malabou, whose research has been questioning the philosophical and cultural implications of the concept, plasticity is both a potentiality for constancy (preserving the organism) as much as for creation (changing the organism) (Malabou 2008, 74). Change, the author notes, is a consequence of the tension between these two aspects that resist to each other. In contemporary theatre, one could say, the actor adapts and reacts to the here-now of the performance. In the shared space of interaction, the actor both gives form to the performance (scripted performance) and receives form from the audience (participant spectator). In such process, he needs to manage levels of representation (of a character) and performativity (of himself-on-stage) that resist to each other. Theatrical playfulness arises from these different kinds of resistance.

In conclusion, contemporary scientific concepts resonate with theatrical ideas of a space of interaction and of a participant spectator. The exposure of both actor and spectator to a space of interaction makes salient questions

of interdependency and suggests the plastic condition of the brain. Directly engaged with the environment, the actor listens to the audience and makes decisions, while the spectator's participation can be thought of as active in the sense that all his/her perception/action have an influence in the actors' performance, thus, in the aesthetics of the theatrical event itself. Contrary to the model that aims at transmitting (and representing) emotions to the spectator, the post-dramatic actor allows for affects to unfold during the here and now, in his play of ambiguity between reality and fiction.

In this way, many performances reactivate a reciprocal movement of affect with the audience that resonates with the ancient notion of receptivity and the body as a process of exchange with the environment. But these contemporary spaces of interaction neither derive necessarily from the use of theatrical space as a dividing wall nor from direct participation of the spectator in the performance. The emphasis on porous and ambiguous boundaries instead of on a clear division of spaces focused on the production of effects blurs the idea of participation itself. To participate is to take part, to be in the event or action. The spectator's passivity – receiving / responding / creating / intensifying an affective atmosphere – takes part in the unfolding of the theatrical event itself. Affect theory, Brennan's model of transmission of affect in particular, allows us to think of spectator's participation both as a social and an aesthetic process, as an intensification of the circulation of affect that impacts on performers on stage. Significantly, this understanding of participation indicates the value such practices of feeling place on the affective dimension of live performance, specifically, on affect transmission as impacting the unfolding of the event. Contemporary performance create worlds of affect that recuperate notions of transmission of affect, embedded in the cultural and scientific moment we are now living, hinting at the ethical and political responsibility of creating worlds of affect.

References

- AUSLANDER, Philip. 2002. "Task and Vision. Willem Dafoe in LSD." In *Acting (re)considered*, edited by Phillip ZARRILLI, 305–310. Londres e Nova Iorque: Routledge.
- BABLET, Denis. 1977. *The Revolutions of Stage Design in the 20th Century*. Paris e Nova Iorque: Leon Amiel.
- BERTHOZ, Alain. 1997. *Le Sens Du Mouvement*. Paris: Editions Odile Jacob.
- BLAIR, Ronda. 2008. *The Actor, Image and Action. Acting and Cognitive Neuroscience*. Londres e Nova Iorque: Routledge.
- BRENNAN, Teresa. 2004. *The Transmission of Affect*. Itaca: Cornell University.

- COLLIER, Jo Leslie. 1988. *From Wagner to Murnau. The Transposition of Romanticism from Stage to Screen*. Ann Arbor: UMI - Research Press.
- CRARY, Jonathan. 1999. *Suspensions of Perception. Attention, Spectacle and Modern Culture*. Cambridge and Massachusetts: MIT.
- DELAHUNTA, Scott. 2005. "Separate Spaces: Some Cognitive Dimensions of Movement." *Diffusion*. http://diffusion.org.uk/species_of_spaces/D_SOS_Delahunta_A4.pdf.
- DELAHUNTA, S., BARNARD, P. and MCGREGOR, W. 2009. "Augmenting Choreography: Insights and Inspiration from Science." In *Choreography in Contexts: Critical Perspectives on Choreographic Practice.*, edited by Liesbeth BUTTERWORTH, Joe WILDSCHUT, 431-448. Nova Iorque e Oxon: Routledge.
- DIDEROT, Denis. 1996. *Oeuvres. Tome IV*. Paris: Éditions Robert Laffont.
- DOLAN, Jill. 2005. *Utopia in Performance. Finding Hope at the Theatre*. Ann Arbor: The University of Michigan Press.
- FÉRAL, J. 2008. "Por uma poética da performatividade: o teatro performativo", *Revista Sala Preta*, 8, pp.197-210.
- GALLESE, Vittorio e RIZZOLATI, Giacomo et. al.. 1996."Action recognition in the premotor cortex", *Brain*, 119, pp. 593-609.
- GOODALL, Jane. 2008. *Stage Presence*. Londres e Nova Iorque: Routledge.
- HURLEY, Erin. 2010. *Theatre & Feeling*. Houndmills: Palgrave.
- HURLEY, Erin e WARNER, Sarah. 2012. "Special Section: 'Affect/Performance/Politics.'" *Journal of Dramatic Theory and Criticism* 26 (2): 99-107.
- KAPROW, Allan. 1966. *Assemblage, Environments & Happenings*. New York: Harry N. Abrams.
- KEMP, Rick. 2012. *Embodied Acting: What Neuroscience Tells Us about Performance*. Londres e Nova Iorque: Routledge.
- KIRBY, Michael. 1965. *Happenings*. Nova Iorque: Dutton.
- LEDOUX, Joseph. 1996. *The Emotional Brain: The Mysterious Underpinnings of Emotional Life*. New York: Touchstone.
- LEHMANN, Hans-Thies. 2006. *Postdramatic Theatre*. Londres e Nova Iorque: Routledge.
- LUTTERBIE, John. 2014. *Toward a General Theory of Acting: Cognitive Science and Performance*. Houndmills: Palgrave.
- MALABOU, Catherine. 2008. *What Should We Do with Our Brain? What Should We Do with Our Brain?* Nova Iorque: Fordham University Press.
- MANNING, Erin. 2009. *Relationescapes: Movement, Art, Philosophy*. Massachusetts: The MIT Press.
- MASSUMI, Brian. 1995. "The Autonomy of Affect." *Cultural Critique* (31): 83-109.
- 2002. *Parables for the Virtual. Movement, Affect, Sensation*. Durham e Londres: Duke University Press.
- MCCONACHIE, Bruce. 2013. *Theatre and Mind*. Houndmills: Palgrave.
- MEYER-DINKGRAFE, Daniel. 2005. *Theatre and Consciousness. Explanatory Scope and Future Potential*. Bristol e Portland: Intellect.

- PACKER, Randall e JORDAN, Ken. 2002. *Multimedia. From Wagner to Virtual Reality*. Londres e Nova Iorque: Norton.
- PLATO. 2000. *The Republic*. Cambridge: Cambridge University Press.
- RIDOUT, Nicholas. 2006. *Stage Fright, Animals and Other Theatrical Problems*. Cambridge: Cambridge University Press.
- . 2008. "Welcome to the Vibratorium." *Senses & Society* 3 (2): 221–231.
- ROACH, Joseph. 1985. *The Player's Passion. Studies in the Science of Acting*. Ann Arbor: The University of Michigan Press.
- SCHIVELBUSCH, Wolfgang. 1988. *Disenchanted Night. The Industrialization of Light in the Nineteenth Century*. Berkeley e Los Angeles: University of California Press.
- SEDGWICK, Eve Kosofsky e FRANK, Adams. 1995. "Shame in the Cybernetic Fold : Reading Silvan Tomkins." *Critical Inquiry* 21 (2): 496–522.
- SHAUGHNESSY, Nicola, ed. 2014. *Affective Performance and Cognitive Science: Body, Brain and Being*. Londres e Nova Iorque: Bloomsbury.
- THOMPSON, James. 2009. *Performance Affects. Applied Theatre and the End of Effect*. Hampshire e Nova Iorque: Palgrave.
- VERGINE, Lea. 2000. *Body Art: The Body as Language*. Nova Iorque: Skira Rizzoli.
- VITRUVIUS. 1931. *On Architecture*. Cambridge e Londres: Harvard University Press.
- WELTON, Martin. 2012. *Feeling Theatre*. Houndmills: Palgrave.
- ZOLA, Émile. 1923. *Le Naturalisme Au Théâtre*. Paris: Fasquelle.

ANA PAIS holds a PhD in theatre studies entitled Commotion: affective rhythms in the theatrical event (University of Lisbon - Portugal). She has worked as theatre critic in the most distinguished Portuguese newspapers and has been working as a dramaturge for both theatre and dance projects in Portugal. She published a study on dramaturgy entitled Discourse of Complicité. Contemporary Dramaturgies (Colibri, 2004) and several articles in national and international journals. Presently, she is a research fellow of Centro de Estudos de Teatro da Universidade de Lisboa.

Analyse sémiotique, identification kinesthésique, engagement du spectateur : quelle réception pour la danse-théâtre ?

CLAUDIA BLOUIN*

Abstract: This paper questions the reception of interdisciplinary in performance arts, more precisely dance-theater. It states that to fully experiment a dance-theater performance, spectator must adopt both semiotic analysis and kinesthetic empathy towards the piece. It also examines new ways of evaluating audience responses to dance such as studies using portable devices on which spectators record their level of engagement towards the choreography, writing methods combining description and analysis of both the performance and the embodied response of the spectator and finally, creative writing workshops answering to watching dance. It concludes that if borders between different art forms have fallen to let them hybrid, the reception to it must also adjust and open to different spectatorial postures in order to engage a dialogue between creators and spectators.

Keywords: dance-theater, reception, semiotic analysis, kinesthetic empathy, interartistic performance

À l'heure où les métissages disciplinaires sont pour ainsi dire la norme sur les scènes occidentales, la question de la réception spectatoriale liée à l'interartistique semble des plus pertinentes à poser. Elle me préoccupe non seulement en tant qu'universitaire, dont la fonction principale est de s'interroger sur ces phénomènes qui touchent aux arts de la scène, mais surtout en tant que spectatrice. Si l'habitude et les études font de moi une spectatrice confortable des salles de théâtre, mon intérêt pour la danse m'amène également à fréquenter les scènes de celle-ci, où je me retrouve souvent prise au dépourvu, ma boîte à outils analytiques et intellectuels n'étant que rarement appropriée pour aborder ces œuvres où le corps est au cœur de la création et donc, de la réception. Théâtre et danse, deux formes d'art qui attendent deux types de spectateurs, du moins deux postures différentes à adopter. Alors, qu'en est-il du métissage entre les deux, qu'en est-il de la réception

* Laval University Québec, Canada, e-mail: claudia.blouin.2@ulaval.ca

de la danse-théâtre¹? Cette dernière appelle-t-elle à un spectateur « métissé » ? Afin de mieux comprendre quelle attitude spectatoriale permettrait l'expérience la plus complète des œuvres issues de la rencontre entre ces deux disciplines artistiques, deux types de réception seront abordés ici : l'analyse sémiotique, abondamment utilisée pour rendre compte des représentations théâtrales et l'identification kinesthésique, qui marque l'échange entre danseurs et spectateurs. À la lumière de la comparaison entre ces deux approches, il semble évident que le métissage danse-théâtre bénéficierait également d'un métissage des postures de réception. Mais comment donner suite à cette façon bicéphale d'aborder la représentation ? Il existe quelques voies, telles qu'une écriture combinant description et analyse du spectacle et de la réaction physique du spectateur ainsi qu'une écriture créative, plus poétique, en réponse à l'œuvre et à ce qu'elle a fait vivre à son public. Voyons donc comment l'ouverture des frontières entre les arts amène l'ouverture d'un dialogue entre créateurs et spectateurs, via une réception repensée.

Imaginons d'abord deux spectateurs se présentant le soir d'un spectacle de danse-théâtre. Le premier fréquente régulièrement les représentations théâtrales. Le deuxième est plutôt amateur de danse. Chacun abordera l'œuvre qui lui sera présentée selon le regard qu'il a l'habitude de porter sur la scène. Règle générale, le théâtre stimule plutôt l'intellect. En offrant une fable, plus ou moins fragmentée, ainsi que toute une panoplie de signes (provenant du jeu des acteurs, des objets présents sur scène, de l'éclairage, de la musique, etc.) à décoder, il appelle à une interprétation qui tient de l'analyse sémiotique, post représentation, à tout le moins post action. La danse, quant à elle, fait plutôt appel au physique, de par une identification kinesthésique, sorte d'empathie corporelle du spectateur aux mouvements effectués par les interprètes sur scène.

La kinesthésie (ou cinesthésie) est la perception consciente de la position ou des mouvements de son propre corps grâce au sens musculaire et à l'oreille interne. Le niveau kinesthésique concerne la communication entre acteurs et spectateurs, comme par exemple la tension du corps de l'acteur ou l'impression qu'une scène peut faire « physiquement » sur le public. Selon l'anthropologie théâtrale de Barba (1995), le spectateur est affecté physiquement par le niveau préexpressif du corps de l'acteur et de la représentation. La danse connaît bien cet impact de la kinesthésie : « Il y a une réponse kinesthésique dans le corps du spectateur, ce qui reproduit en lui en partie l'expérience du danseur². »

¹ Ici, « danse-théâtre » inclura toute forme de rencontre scénique entre danse et théâtre, sans discrimination pour les œuvres qualifiées de « théâtre dansé » ou toute autre acception semblable.

² Patrice Pavis, « Kinesthésie », dans *Dictionnaire du théâtre*, Paris, A. Collin, 2003, p. 190.

Bien que cette identification kinesthésique puisse parfois intervenir au théâtre, tel que l'indique la définition de Patrice Pavis ci-dessus, elle appartient principalement au domaine de la danse et en est le mode de réception privilégié.

Nous nous retrouvons donc d'un côté avec un engagement par rapport à la représentation qui soit essentiellement intellectuel et en constant décalage avec l'action qui a lieu sur scène. L'analyse sémiotique d'un élément scénique se produisant toujours un temps après son apparition, le spectateur effectue de nombreux allers-retours entre ce qu'il est en train de voir et ce qu'il a vu précédemment, ajustant son interprétation de chaque nouvel élément en le positionnant par rapport à ceux qu'il a déjà « décodés ». À titre d'exemple, j'ai assisté en 2014 à une représentation du spectacle *Gustavia*, par Mathilde Monnier et La Ribot, où ces danseuses, au début, font semblant de pleurer de façon très exagérée. En bonne spectatrice de théâtre, cette scène m'a portée à réfléchir, à me demander ce qu'elle pouvait représenter symboliquement. Et pendant que je me disais qu'elles ressemblaient à des pleureuses professionnelles de funérailles, je n'étais plus engagée physiquement avec ce qui se passait sur la scène, mais plutôt dans ma tête. Puis, plus tard dans la représentation, après avoir constaté que la thématique de l'image de la femme traversait l'œuvre, je



Fig. 1 : Mathilde Monnier et La Ribot, DANS *Gustavia*, Centre chorégraphique national de Montpellier Languedoc-Roussillon, <http://www.montpellierdanse.com/spectacle/gustavia.html>

me suis remise à penser à la première scène des pleurs et à me dire qu'elle représentait peut-être une image péjorative de la femme hypersensible, voire hystérique. C'est dire le décalage temporel qui me séparait à ce moment-là des danseuses en action, dans le présent, alors que ma pensée, elle, était retournée en arrière. Le spectateur ayant une approche plus théâtrale peut donc difficilement vivre l'ici et maintenant de la représentation, trop occupé qu'il est par l'analyse des éléments qui lui sont présentés.

De l'autre côté, la réception de type danse suscite un engagement physique du spectateur, plus ancré dans le temps réel de la représentation, mais ne prenant pas vraiment compte du contexte (culturel, esthétique, social) de l'œuvre présentée sur scène, à défaut d'en faire une analyse. Le spectateur de la performance *Prêt-à-baiser* d'Olivier Dubois, par exemple, peut très bien se laisser porter, durant les 45 minutes du spectacle, par l'identification kinesthésique provoquée par la tension avec laquelle les deux interprètes ne cessent de jouer. Ceux-ci, en effet, débutent par un rapprochement extrêmement



Fig. 2 : *Prêt-à-baiser*, chorégraphie d'Olivier Dubois, 2012, Photo : Boris Munger, <http://www.paris-art.com/spectacle-danse-contemporaine/S%C3%A9quence%20danse.%20Pr%C3%AAt%20%C3%A0%20baiser/S%C3%A9quence%20danse.%20Pr%C3%AAt%20%C3%A0%20baiser/7865.html>

lent qui se conclura, près de 15 minutes plus tard, par un baiser libérateur, mais de plus en plus violent, à mesure que se déploie l'épique musique du *Sacre du printemps* de Stravinski. Chorégraphie des langues, des visages qui se dévorent, puis des corps qui luttent. Cependant, si le spectateur s'arrête seulement à ce qu'il a ressenti physiquement – dans mon cas, à la tension qui m'a gardée sur le bord de mon siège, à l'affût des nuances microscopiques dans les mouvements des deux corps – il risque de passer à côté de toute la profondeur de cette œuvre qui réside notamment dans la métaphore que ce long baiser suggère. En effet, plus qu'à deux hommes qui s'embrassent, c'est à la lutte du désir entre l'Artiste et sa Muse que Dubois veut renvoyer. Pour ce faire, il utilise des signes autres que les corps, le lieu, par exemple, qui dans ce cas-ci est un musée et convoque l'imaginaire relié à l'acte de création. Par contre, si le spectateur ne se fie qu'à sa réception sensorielle de la chorégraphie, il n'aura pas accès à au sens que l'auteur veut en donner.

Il semble que la danse-théâtre, quant à elle, cherche à réunir ces deux postures spectatoriales – sensorielle et analytique – que l'on pourrait juger d'incomplètes, et ce, dans le but d'en exploiter la complémentarité et de susciter un engagement global du spectateur. La danse-théâtre est en effet traversée de signes qui paraissent porteurs de tout un réseau de sens, voir constituant une fable, mais dont la clé semble glisser entre nos doigts. Michèle Febvre donne une description juste de la mobilité des signes proposés par la danse-théâtre, cette qualité qui oblige le spectateur à les aborder autrement que par l'analyse purement sémiotique :

Dans la danse qui nous intéresse ici [théâtrale], la production du sens se fait dans cette traversée d'un monde de signes mobiles (au propre et au figuré) gestuels, visuels et sonores ; on assiste à leur ensemencement réciproque dans une sorte de conduite ludique qui fait déraiper le sens chaque fois qu'on croit le saisir ; circulation et circonvolution des signifiants, entre et sur eux-mêmes, dont les signifiés seraient toujours à venir, débordant l'espace sémantique dans lequel on voudrait les contenir, créant, en quelque sorte, un « suspens » signifiant. Entre l'obvie et l'obtus quand l'évidence, un instant perçue, se trouble et devient caduque. Ailleurs, encore³.

Il semble donc que ces signes qui échappent à l'emprise de notre compréhension intellectuelle tendent à glisser de notre tête à notre corps dans le but de se faire ressentir plutôt que décrypter. Il en est ainsi dans la fameuse

³ Michèle FEBVRE, « Les paradoxes de la danse-théâtre », dans *La danse au défi*, Montréal, Parachute, 1987, p. 75.

scène de *Café Muller* de Pina Bausch, citée par Febvre plus loin dans son article, où un des interprètes sépare un couple enlacé, place la femme dans les bras de l'homme. La danseuse glisse, chute au sol et l'enlace à nouveau.



Fig. 3 : Image de la production *Café Muller*, chorégraphie de Pina Bausch, Tanztheater Wuppertal, 1978. Photo : capture de l'enregistrement réalisé par la télévision allemande. <http://esquizofia.com/2011/06/09/devirdancar-7/>

À cette représentation première se substitue peu à peu, par la répétition et l'accélération de la séquence, la charge énergétique et expressive (au sens des forces en action dans le corps) des mouvements de la femme, s'érigeant et tombant sans arrêt jusqu'à l'épuisement. La répétition, ici, libère le stéréotype et fait accéder la figure à une espèce d'évidence sensorielle, immédiate et violente, supplantant la représentation. Théâtre de la cruauté... ou le sens au cœur de la sensation⁴.

Le sens dégagé par le premier enchaînement de la séquence laisse place à la pure dépense énergétique de la danse, soulignée par les respirations haletantes des interprètes, que le spectateur ressent plus qu'il ne la comprend. L'analyse et l'identification physique, ici, se complètent et permettent au spectateur de vivre pleinement la scène, la dimension sémiotique n'éclipsant

⁴ *Ibidem*, p. 76.

pas la dimension sensorielle et vice versa. Cette combinaison entre stimulation intellectuelle et physique est la principale force de cette scène, et de la danse-théâtre en générale, celle qui fait qu'elle reste imprégnée dans la mémoire des spectateurs qui y ont assisté ou l'ont même seulement vu en vidéo.

Comment, donc, rendre compte de cette réception dialogique, où doivent se côtoyer sens et sensation pour que l'expérience soit complète ? Il me semble que ni la critique journalistique ni les analyses académiques conventionnelles ne permettent de partager adéquatement l'expérience globale de la réception d'un spectacle de danse-théâtre, parce qu'elles n'incluent pas le ressenti physique du spectateur par rapport à ce à quoi il a assisté. En ce sens, certaines études ont été menées afin d'arriver à quantifier le niveau d'engagement du spectateur lors d'une représentation de danse contemporaine, aspect de la réception passablement mis de côté jusqu'à il y a quelques années encore.

Dans « Structure and Aesthetics in Audience Responses to Dance », la chercheuse Kim Vincs propose un outil de mesure en temps réel et en continu de la réponse à la danse pour comprendre les divergences et les convergences de réaction au sein des membres du public. Pour l'étude, elle a utilisé un petit appareil portable que les spectateurs avaient à la main et avec lequel ils enregistraient leur niveau d'engagement par rapport à la représentation. Elle cherchait ainsi à rendre compte de la subjectivité qui découle de la perception du mouvement dans les termes de la spatio-temporalité qui fait défaut dans les analyses sémiotiques. « The result of these experiments show that audiences do display some agreement in their responses to dance, and that choreographic phrasing in the sense of tension and release – increasing expectation and the fulfilment or delay of expectation – has some bearing on these responses. »⁵ Il apparaît donc possible de tirer des conclusions générales quant au ressenti d'un groupe de spectateurs face à un spectacle et donc de dépasser la simple analyse de l'œuvre en tant que telle et prendre en compte scientifiquement son effet sur les êtres qui la reçoivent.

L'auteure Katherine Cornell propose quant à elle, dans son article « Seeing and Experiencing Chouinard : The Body Language of the Spectator », une méthode d'écriture qui combine plusieurs approches afin d'inclure la réponse corporelle du spectateur dans l'interprétation des signes véhiculés par les corps dansants. Sa méthode vise une description qui serait faite par un spectateur « incarné », aussi *groundé* et connecté à ce qui se passe sur la scène que le danseur lui-même. Il s'agira de décrire à la fois ce qui se passe sur la

⁵ Kim Vincs, « Structure and Aesthetics in Audience Responses to Dance », dans Jennifer Radbourne, Hilary Glow et Katya Johanson (dir.), *The Audience Experience: a critical analysis of audiences in the performing arts*, The University of Chicago Press, 2013, p. 132.

scène, mais également dans le corps de celui qui regarde, rendant ainsi compte de la nature événementielle de la représentation. Elle met en application sa théorie en proposant au lecteur sa réponse au solo masculin *Des feux dans la nuit*, chorégraphié par Marie Chouinard en 1999.

Soon the arm movements increase in intensity and speed. He looks like he is tossing a ball between his hands. The actions of the arms affect the torso sending waves of convulsions upward. He succumbs to the crouch by bending his knees and pressing his weight into the ground then his upper body soars into the spread eagle arm position as he stands upright. With head bowed, he resembles a man hung on a crucifix. The light catches the glistening reflective tape on the top of his head.

I find myself holding my breath as his body convulses, as if his movements are trapping the air in my body. This section makes my body feel claustrophobic⁶.

Cet exemple montre bien les trois dimensions offertes par ce type d'écriture : la description de ce que l'interprète donne à voir sur scène, l'analyse des éléments perçus à travers la métaphore de la crucifixion et la réaction corporelle de la spectatrice (en italique dans l'exemple) qui se sent prise à l'intérieur de son propre corps. Ce qui m'amène à penser qu'elle crée une nouvelle manière d'aborder et surtout de partager la réception de la danse, aussi applicable à la danse-théâtre, par un métissage de l'analyse sémiotique et de l'identification kinesthésique. Cependant, si on la compare à l'étude de Kim Vincs, l'évaluation de Cornell est davantage qualitative, en ce sens qu'elle décrit comment son corps réagit, que quantitative, là où les sujets de l'étude devaient simplement donner un degré d'engagement entre 0 et 10. Sans permettre une évaluation statistique de la réception de plusieurs spectateurs d'une même représentation, la deuxième méthode rend tout de même compte beaucoup plus en détail de l'expérience vécue, sans esquiver complètement une analyse tout de même nécessaire à la saisie des signes présents dans l'œuvre et ayant leur résonance chez le public. L'exemple que Cornell donne de sa réception de *Des feux dans la nuit*, tout en étant empreint de sensibilité, remplit les critères d'un papier académique de qualité. Ce nouveau type de critique offre selon moi de grandes possibilités pour entamer un dialogue constructif entre les artistes et les spectateurs/ chercheurs. Il donne accès aux créateurs à la manière dont leur œuvre est non seulement comprise par leur public, mais comment elle les touche physiquement, qu'est-ce qu'elle fait vibrer à l'intérieur de leur corps.

⁶ Katherine CORNELL, « Seeing and Experiencing Chouinard: The Body Language of the Spectator », dans *Ethnologies*, vol. 30, no. 1, 2008, p. 166.

Dans un même ordre d'idées, dans le cadre de *The Watching Dance Project*⁷, le chercheur anglais Matthew Reason, lors d'une expérience réalisée en 2010, a utilisé des ateliers de création littéraire dans le but d'étudier la réponse du public à un spectacle de danse. Par le passé, il avait utilisé le dessin et la peinture dans une visée semblable. Le choix de l'écriture est ici motivé par le défi que représente l'usage du langage pour rendre compte d'une expérience principalement sensorielle. Dans la même optique que ce qui a été discuté précédemment, ses recherches visent à lier les aspects intellectuel et physique de la réception spectatorielle, par la verbalisation d'un phénomène impliquant le corps dans une grande proportion. Voici une phrase écrite par un des participants lors d'un exercice d'écriture spontanée et qui rend compte du lien fondamental qui unit ces deux dimensions de la réception. Elle est suivie du commentaire qu'en fait Reason sur le blog qui documente l'étude :

« Tormented by the body, frozen in stilted motion, a world in which normal movement has become an unfamiliar thing. »

This is something that I suspect we can quite readily agree is an evocative phrase, it is full of affecting imagery, it encourages us to feel what it describes – emotionally and/or physically – rather than that simply see it. Importantly it encourages us to engage in this emotional /physical affect whether or not we have seen the performance that is being described⁸.

Ainsi, le participant réussit à décrire non seulement ce qu'il a vu, mais ce qu'il croit que ressentent les interprètes du spectacle, et donc l'identification kinesthésique qu'il a lui-même vécue en les regardant bouger. On constate alors l'atteinte d'un des objectifs de l'expérience qui était de doter les spectateurs de la danse, et plus globalement des arts de la scène, d'outils leur permettant de s'exprimer sur ce à quoi ils ont assisté et ce qu'ils ont vécu lors de la représentation. S'il s'agit encore là d'une méthode donnant accès au ressenti des spectateurs, le partage auquel il ouvre permettrait également, selon moi, d'entrer en discussion avec les artistes qui pourraient eux-mêmes être inspirés par les œuvres littéraires créées par leur public. Ce qui m'amène à imaginer d'autres ateliers, d'écriture chorégraphique et théâtrale par exemple, où les spectateurs pourraient donner corps à leur réception des œuvres tout en en créant de nouvelles, donnant lieu à un cycle créatif d'expression et de dialogue.

⁷ THE WATCHING DANCE PROJECT, *Watching Dance: Kinesthetic empathy*, [En ligne], 2015. [<http://www.watchingdance.org/>] (15 juillet 2015).

⁸ Matthew Reason, « Tormented by the body », *Dance Audiences Writing Dance*, [En ligne], 8 février 2011. [<http://audienceswriting.blogspot.ca/2011/02/tormented-by-body.html>] (24 juillet 2015).

Aux arts sans frontières qui échangent comme des vases communiquant, il n'en tient qu'au public d'offrir une réception sans limites, à l'écoute de l'intellect comme du corporel et s'exprimant dans l'optique d'un partage qui ferait avancer la recherche universitaire et artistique.

Références

- CORNELL, Katherine, « Seeing and Experiencing Chouinard: The Body Language of the Spectator », dans *Ethnologies*, vol.30, no.1, 2008, p.157-176.
- FEBVRE, Michèle, « Les paradoxes de la danse-théâtre », dans *La danse au défi*, Montréal, Parachute, 1987, p.75.
- PAVIS, Patrice, *Dictionnaire du théâtre*, Paris, A. Collin, 2003, 447 p.
- REASON, Matthew, *Dance Audiences Writing Dance*, [En ligne], 8 février 2011. [<http://audienceswriting.blogspot.ca>] (24 Juillet 2015).
- THE WATCHING DANCE PROJECT, *Watching Dance: Kinesthetic empathy*, [En ligne], 2015. [<http://www.watchingdance.org/>] (15 juillet 2015).
- VINCS, Kim, « Structure and Aesthetics in Audience Responses to Dance », dans Jennifer Radbourne, Hilary Glow et Katya Johanson (dir.), *The Audience Experience: a critical analysis of audiences in the performing arts*, The University of Chicago Press, 2013, p.129-142.

CLAUDIA BLOUIN is an M.A. student in Littérature et arts de la scène et de l'écran, theater profile at Laval University (Québec, Canada). Her main research interest is interdisciplinarity in performance arts such as dance-theater. Her memoir interrogates the dramaturgic and theatrical potential of music in the choreographic creative process. In order to document her research, she did field studies in France where she interviewed choreographers and music composers. Part of the results were presented in an international conference at Bacau (Romania)'s Vasile Alecsandri University in May 2015. She is also a research auxiliary on an historical synthesis project about theatre in Quebec since 1945.

Towards Embodied Spectatorship

RAMUNĖ BALEVIČIŪTĖ*

Abstract: The article discusses the cognitive approach to spectatorship. There are different aspects that interest theatre scholars in the field of spectating research, for example, how audiences perceive the process of acting, how emotions and empathy work, and how spectators create meanings. The main premise for the cognitive approach to spectating is that the engagement of the audience in the performance is foremost corporeal. The article analyses the roots of this standpoint and poses a question concerning the possibility of measuring the impact of theatre. Further, the statement that for spectators the most significant engagement with a performance is emotional is considered. The concept of empathy and kinaesthetic empathy in particular is discussed. The article suggests that the crucial specification for successful audiences' embodiment is embodied acting and trained body-mind that in fact means coherence within and between the mental and emotional systems. Proposing that most reliable data about the effect of the performance is medical examination, this article introduces the research *Thinking Body: Acting Systems' Analysis and Integration in the Process of the Work of a Contemporary Actor* which was implemented at the Lithuanian Academy of Music and Theatre in 2013–2014. The article suggests that interdisciplinary research with the collaboration of theatre scholars and artists as well as specialists of medicine would help estimate what conditions are most favourable for effective communication between performers and spectators.

Keywords: cognitive approach, audience, spectatorship, emotion, empathy, affect, embodied acting.

Efforts to reconsider and to reconfigure the relationship between theatre and its audiences were among the most important objectives of various theatre experimenters of the twentieth century. Nevertheless, theatre theoreticians were occupied mostly by describing and analyzing the artistic strategies of directors rather than the engagement of the audience itself. But for the 'emancipated spectator', the discourse relating to theatre audiences recently

* Lithuanian Academy of Music and Theatre, Vilnius, Lithuania, e-mail: ramune.baleviciute@lmta.lt

has become one of the main topics in the theatre studies; however, the major interest of researchers remains the kinds or types of theatre that provoke an active audience participation. For example, Gareth White, the author of the study *Audience Participation in Theatre: Aesthetics of Invitation*, distinguishes two leading models of participatory theatre: *immersive* theatre and *one-to-one* theatre. As White asserts,

fashions for “immersive” theatre and “one-to-one” theatre are in the ascendancy; the former tends to make use of spatial and architectural interventions, and to ask spectators to involve themselves physically in tracking down or pursuing the performance; the latter seeks a more direct relationship with the individual spectator. [White 2013, 2]

Cognitive approach to spectatorship

The idea that the role of the audience in so-called traditional or conventional theatre and non-traditional theatre is absolutely different is very popular. This viewpoint suggests that in conventional theatre audiences are passive. According to Susan Bennett, ‘With [the] social contract put into place, usually by the exchanging of money for a ticket which promises a seat in which to watch an action to unfold, the spectator accepts a passive role and awaits the action which is to be interpreted’ [Bennett 1990, 177]. Meanwhile in non-traditional theatre events, the audience is actively and creatively engaged. However, many philosophers and theatre scholars object identifying the ‘simple’ act of watching as passivity. White also agrees that ‘all audiences are participatory’ [White 2013, 3] even in the case of a very traditional performance with a steady fourth wall. This is the main premise for the cognitive approach to spectating in theatre. The proponents of this approach are mainly interested not in *how* audiences are being engaged in the performance but rather *what* is happening to the spectator while watching it, or *what audiences do*.

In general, it is believed that unlike the theories of the twentieth century, ‘the mind sciences offer no central authority, no revered group of texts that disclose a pathway to the authorized truth’ [Lutterbie 2011, x]. First of all, cognitive studies that include scientific investigation into psychology, linguistics, and neuroscience and also encompass the insights in philosophy, anthropology, and humanities, create a certain framework for understanding, but also challenging various theories and practices that are in the focus of contemporary theatre and performance studies. As Bruce McConachie claims,

Cognitive science can offer empirically tested insights that are directly relevant to many of the abiding concerns of theatre and performance studies, including theatricality, audience reception, meaning making, identity formation, the construction of culture, and processes of historical change. [McConachie 2006,]

There are different aspects that interest theatre scholars in the field of spectating research, for example, how audiences perceive the process of acting, how emotions and empathy work, and how spectators create meanings. It should be said that the cognitive approach to spectatorship visibly differs from semiotic and psychoanalytic approaches. First and foremost, the act of reception of theatre performance should not be equated only to the 'reading' of it¹, i.e. it is not only about decoding the signs in hermeneutic sense and thus making the meanings. In her famous study *Ästhetik des Performativen* (2004) Erika Fischer-Lichte demonstrates that the process of creating meaning in contemporary performance is not hermeneutic in its nature. According to Lichte, the performance cannot be understood, it should rather be experienced. Lichte emphasizes the corporeality of the acts the actors are performing, which replaced the meaning of that act, the same as an audience reaction is foremost bodily. Moreover, the bodily impact on all participants in the performance became the primary purpose and the primary reality of the performance. In *The Dynamics of Drama*, Bernard Beckerman writes about the 'muscular tension' experienced by audience members:

Although theatre response seems to derive principally from visual and aural perception, in reality it relies upon a totality of perception that could be better termed kinesthetic. We are aware of a performance through varying degrees of concentration and relaxation within our bodies. ... We might very well say that an audience does not see with its eyes but with its lungs, does not hear with its ears but with its skin [cited in Freshwater 2009, 18].

The roots of this holistic attitude go back to so-called *cognitive turn* or *bodily turn* of the second part of the twentieth century. The ideas of Maurice Merleau-Ponty have essentially changed the approach to the expression of body and the structure of experience. Merleau-Ponty rejected the dualism of mind and body and gave a special prominence to lived body (*Leib*), which takes part in the constitution of experience: the world comes into being and is experienced through the body. To put it in another way, our relationship with

¹ In his study on performance and cognition, Howard Mancing directly assaults the approach to watching a play as a process of reading: "Perceptual understanding, the primary cognitive mode in nature, is not at all linguistic, and by definition it cannot involve "reading"" [Mancing 2006, 191].

the world is corporeal. The findings in neuroscience demonstrated that mind does not passively accept the sensory data, but rather provides with a kinaesthetic awareness of the place and space and devises some action plans to engage with the environment. Many scholars, who investigated the correlation between thinking and perceiving, stated that perceiving is a kind of acting.² Alva Noë, for instance, in his book *Action in Perception* (2004) claimed that “perception is not something that happens to us, or in us. It is something we do. ... The world makes itself available to the perceiver through physical movement and interaction. ... We enact our perceptual experience; we act it out” [cited in Zarrilli *et alii* 2013, 26].

In this respect, performing as well as spectating can be viewed as cognitive activities. Bruce McConachie introduces the term *ecology of spectating*. Relying on the observation that the modes of spectating are highly context-dependent, he claims that activities of spectating are always embedded in a material and social situation: “From an Enaction perspective, perception, like the rest of cognition, is not only embodied and embedded, it is also ecologically extended. Spectators use their material and social surroundings as well as their bodies and brains to take action and make meaning during a performance” [McConachie 2013, 186]. Certainly, the surroundings and social determination are important in the process of spectating, but I suggest that nevertheless an actor is the most important agency. I will elaborate this argument later in this text.

Is it possible to measure the impact of the theatre?

Most of the approaches treat spectatorship as a general process, i.e. they analyze the mechanisms of perceiving, necessary conditions, confines and influential factors etc., but they do not try to evaluate the effectiveness of communication that in fact is the main concern of theatre. Or if they do, usually the arguments are speculative. One might assert that it is impossible to measure the impact of the performance on the audience and this is partly true. The only reliable data could be questionnaires of the audience members and/or medical measurements.

² See, for example, the works of Tim Ingold *The Perception of Environment* (2000) and *Being Alive: Essays on Movement, Knowledge and Description* (2011) or studies of Mark Johnson *The Body in the Mind: The Bodily Basis of Meaning, Imagination, and Reason* (1987) and *The Meaning of the Body: Aesthetics of Human Understanding* (2007). The main premise for the **perception-action** approach is that evolution shaped humans’ perceptual processing primarily for action (not for reaction or information gathering).

One of the complicated aspects of this problem is that what we call “the audience” is not a singular or homogeneous entity. The responses of the spectators might be very diverse and sometimes unexpected, for they depend on many factors such as class, gender, nationality, religious background, ethnicity, sexuality, geographical location, and education. Thus, it would be more relevant to talk about the “audiences” rather than the “audience”. However, sometimes theatre researchers and especially theatre critics speculate about an “audience response”, relying only on their own personal reception or a throughout subjective observation of the auditorium. Usually this works as a support of the writer’s arguments. Yet, as Helen Freshwater notes,

[the] engagement with “ordinary” members of the audience is notably absent from theatre studies. ... While academic theatre studies continues to engage with hypothetical models of spectatorship, statistical analysis of historical audiences, or the writer’s personal experience, theatre marketing departments are busy surveying the opinions and responses of real audiences... ... This may be surprising, but academic scholarship and the theatre industry have very different motivations for their interest in audiences and pursue very different forms of inquiry as a result [Freshwater 2009, 29-30].

One could propose that namely the cognitive approach to spectatorship is about “ordinary” members of the audience. However, even the proponents of this approach do not avoid purely hypothetical insights. Considering spectating as a cognitive activity, in some cases they automatically transfer the knowledge about general cognition to spectating and without any scientific proof the result is nothing but an interesting assumption.

The domain of emotion

Many researchers of spectatorship claim that for spectators the most significant engagement with a performance is emotional “because emotions are the most relevant index of spectator enjoyment and meaning-making” [McConachie 2013, 189]. McConachie proposes that “Good performance situations provide a safe space in which actors and spectators can explore many of their emotional vulnerabilities and needs without embarrassment” [*Ibid*, 189]. Furthermore, he claims that “The length and intensity of dramatically generated emotions are crucial factors in shaping the emergence of meanings for spectators” [*Ibid*, 194]. Both arguments, regarding the therapeutic aspect and intensifying the process of meaning-making, are worth reconsidering.

Let's start with posing the question: Is the performance situation really a "safe space" and are the spectators as well as the actors really sheltered from "embarrassment"? In 2013, together with my colleagues-artists at the Lithuanian Academy of Music and Theatre, physiotherapists and specialists of biomedicine we initiated the experimental research project *Thinking Body: Acting Systems' Analysis and Integration in the Process of the Work of a Contemporary Actor*. The most innovative part of the project was the evaluation of the cardiovascular indicators of the students of acting with different psycho-emotional status performing dramatic, comic and tragic roles as well as relaxation exercises.³ The students were asked to perform one monologue from Shakespeare's *Macbeth* in three different manners – as drama, tragedy and comedy in the way they felt it (with no director's references). The aim of the study was to assess dynamic characteristics of the students "ECG parameters, depending on the subjects" psycho-emotional status during different genre roles. The basis of the study was the findings of psychophysiologicalists in heart-brain neurodynamics and particularly the insight that through its extensive interactions with the brain and body, the heart emerges as a critical component of the emotional system.⁴

The research revealed considerable dynamic changes in the RP parameter (regulatory system) and JT parameter (heart metabolism).⁵ To put it simply, this means that the actor's organism, while experiencing various emotions, gets strongly misbalanced during the process of performing. In other words, performers are experiencing a high level of stress. Interestingly, the maximum individual change coincided with that of the person's favourite genre, which among most of the participants was tragedy. According to the authors of the research, these results can be considered as positive since they demonstrate the actors' empathy with the character or the engagement in a theatrical

³ The examination was made by medical researchers Alfonsas Vainoras, Ernesta Sendžikaitė and Roza Joffé, all working at the Lithuanian University of Health Sciences, and Tadas Telksnys, a specialist of applied mathematics.

⁴ This concept was elaborated by Rollin McCraty, the Director of Research of the HeartMath Research Center at the Institute of HeartMath based in California. See his publication "Heart-Brain Neurodynamics: The Making of Emotions" on <https://www.heartmath.org/assets/uploads/2015/03/heart-brain-neurodynamics.pdf>

⁵ The research was introduced in the publications 'Evaluation of the Cardiovascular Indicators of Future Actors with Different Psycho-Emotional Status Performing Dramatic, Comic and Tragic Roles as well as Relaxation Exercises' in a collection of scientific articles *Acting Reconsidered: New Approaches to Actor's Work* (Lithuanian Music and Theatre Academy, 2014) and 'Changes of Future Actors ECG Parameters During Different Genre Roles' in the proceedings of the international conference *Biomedical Engineering 2014* (Kaunas University of Technology, 2014).

situation. The students themselves described their state while performing tragedy as satisfying and creative. The problem occurs after the performance when even after the relaxation exercises the organism does not return to its normal condition. That was especially true of the students with stronger symptoms of depression. Thus the effect at least on the actors is not therapeutic at all.

Of course the nature of the research was purely experimental and some limitations should be considered (for example, there was no “true” audience, only the researchers; the time of the performance was quite short; the experiment ought to be repeated under different circumstances etc). Moreover, the findings of the experiment deserve further analysis. They gave a strong impulse to reconsider the current methods of actors training as well as to explore the most favourable conditions for creation – of actors and of spectators.

It is possible that the audience’s physiological answer would respond to the actor’s curve of dynamic changes in the regulatory system and heart metabolism, i.e. the intensive emotions of the actor might cause the intensive emotional response from the audience. This can be possible because of the corporeal character of the perception: the body of a spectator reacts to the body of an actor. Moreover, the stated assumption can be grounded by the mechanism of empathy which, according to McConachie, is “crucial for spectators attempting to negotiate and understand both the theatrical and the dramatic levels of all performances’ [McConachie 2013, 191]. Because empathy leads spectators to emotional engagements⁶, it might seem that emotions are prioritized by many researchers as well as by creators of new acting and actors training methods. Discovery of the corporeal nature of an emotion as well as the implication that the actor does not have to experience the “real” emotion himself/herself in order to be “truthful” has led to various investigations of how to produce an emotion on stage. Here, the research of experimental psychologist Paul Ekman was of great importance. Briefly, Ekman, in his study *Emotions Revealed: Recognizing Faces and Feelings to Improve*

⁶ Current scientific definitions of “empathy” range widely. The ‘theory of mind’ advocated by some psychologists in the last decades of the twentieth century was demolished, for empathy is largely unconscious and proactive. Neurobiologist and phenomenologist Evan Thompson understands empathy from an Enaction point of view. For Thompson, empathy is a four-level mechanism, starting from ‘sensorimotor coupling’ based on the networks of mirror neurons, and ending up with ‘golden-rule’ ethics which causes fairness and respect in human relationship. See: Thompson, Evan. *Mind in Life: Biology, Phenomenology, and the Sciences of Mind*. Cambridge, MA: Harvard University Press, 2007, p. 393-402.

Communication and Emotional Life (2003), has shown that consciously chosen muscular actions affect the emotional state (however, he mostly concentrated on the facial muscles). One of the most coherent methods based the scientific discovery that the conscious reproduction of certain physiological symptoms can provoke the affective experience of emotion, is Susana Bloch's *Alba Emoting, A Psychophysiological Technique to Help Actors Create and Control Real Emotions*. This method is based on the effector patterns of different emotions. In short, Bloch suggests that the control of breathing, muscular tension and activity, and facial expression can generate emotion.⁷

Why is it so important for an actor to know how to (re)produce an emotion? As Rhonda Blair claims, "The powerful degree of interpretation involved in translating emotional/body states into feeling⁸ reinforces the idea of the actor's freedom to think creatively in imagining a role" [Blair 2006, 176]. As for the spectators, they wish to experience deep emotions at the theatre; however, the question is not so unambiguous. The first question is whether only the ability to create a concrete emotion opens up the creativity of an actor. The second question is whether only the recognition of an emotion evokes the emotional audience response (for recognition is not the same as embodiment). And finally we can ask whether emotional experience is the only one we expect as theatre goers.

Empirical observations as well as testimonies of the actors confirm that audience responses might be quite controversial. Every actor from his/her experience could testify that sometimes all the actions performed in order to produce a certain emotion are right; however, they do not get an adequate response or feedback from the audience. Or the emotion can be recognizable, but it does not "infect" or "affect" the audience.⁹ In this regard, the techniques

⁷ More about *Alba Emoting* see Bloch, S. *The Development of Alba Emoting*, BYU-Idaho Press, 2003 and Bloch, S., Orthous, P. and Santibañez-H, G. 'Effector Patterns of Basic Emotions: A psychophysiological method for training actors' in *Acting (Re)Considered. A Theoretical and Practical Guide*. 2nd edition. Ed. Phillip B. Zarrilli. Routledge, 2002, p. 219-238.

⁸ Many acting researchers have turned back to the investigations of emotions by the prominent neuroscientist Antonio Damasio. He has demonstrated that emotions are biological responses or brain representations of the states of the body, while feelings are conscious mental formulations of the emotions. According to Damasio, feelings 'translate the ongoing life state in the language of the mind' [Damasio 1999, 85]. A feeling is 'the perception of a certain state of the body along with the perception of a certain mode of thinking and of thoughts with certain themes' [*Ibid*, 86].

⁹ Here the fervid outgiving of Anne Bogart is relevant: "I cringe if I hear an actor say, "If I feel it, they will feel it". The notion that the actor and the audience feel the same sensations at the same moment leads to a solipsistic approach to acting and easy dismissal on the part of the audience" [Bogart 2010, x].

that only teach an actor to produce emotions can be considered as quite limited. Moreover, a human being is not controlled only by emotions; we also have our beliefs, intensions etc. And what we expect from theatre is not only “enjoying ourselves” by experiencing emotions, as McConachie puts; we also expect some new comprehension of life and ourselves. Thus, the thesis that intensive emotions provoke thinking and reflection is not always valid. A good illustration could be the comparison of two genres – melodrama and tragedy. Melodrama brings an emotional relief, while tragedy alongside the emotions produces some new understanding. On the other hand, science has proved that the most pervasive thoughts are those fuelled by the greatest intensity of emotion. However, it tells nothing about the nature of those thoughts – whether they are critical or stereotypical.

Ultimately, we should consider cogitating not about *emotional* empathy, but rather *kinesthetic* empathy. The term was appropriated mostly from dance studies that presented quite a lot of valuable research in this field.¹⁰ Kinesthetic empathy means that spectators experience the actor as not or not only as a new identity, which consists of the actor’s and character’s identities as the cognitive approach suggests, but foremost as a moving body. As Dee Reynolds puts, “Kinesthetic empathy is linked to the affect rather than to the emotion. This means that kinesthetic empathy can be considered as embodied intensity which has an impact on the spectator in a kinesthetic manner” [cited in Pavis 2014, 7]. “Affect” is a broader concept than “emotion” and it involves a spectrum of experiential phenomena – physical, emotional and behavioural. However, scientists strongly disagree about this term.

Whether empathy is kinesthetic or of another kind, we can agree with McConachie who claims that “There is no guarantee, however, that empathizing spectators will succeed in embodying and understanding the emotions and beliefs of actor/characters, performer-facilitators, or even fellow audience members” [McConachie 2013, 193]. In my opinion, this is so because there is still no evidence what relationship is between impact or affect and meaning-making. Anyway, the main concern of theatre makers is how to enable new experience for the audience, how to establish the most favourable circumstances for effective communication, even if the notion of “effectiveness” is quite unspecified. As a handicap for successful communication which produces

¹⁰ See, for example, Matthew Reason, Dee Reynolds, Marie-Hélène Grosbras and Frank E. Pollick “Researching Dance Across Disciplinary Paradigms: A Reflective Discussion of the Watching Dance Project”. In: *Affective Performance and Cognitive Science. Body, Brain and Being*. Ed. Nicola Shaughnessy. Bloomsbury, 2013, pp. 39-56.

new experience, McConachie considers initial cultural stereotypes. I would suggest that the reason for communication failure is not only cultural stereotypes but many other factors as well, and the acting (performing) is of the utmost importance. Or not even the performing, but the state of the actor. The researchers at the Institute of Heart Math have demonstrated that creativity as well as other parameters such as reaction times, mental clarity and problem solving, is influenced by the degree of coherence of mental and emotional systems. As Rollin McCraty puts, "When the mental and emotional systems are in sync, we have greater ability to manifest our visions and goals, as the power of emotion is aligned with the mind's capacities" [McCraty].

The notions of **bodymind**¹¹ and of **embodied acting** used by some theatre practitioners might be treated as the equivalent of the concept of coherence. Likewise, theatre makers propose to train embodied acting and the actor's bodymind in order to enhance the actor-audience communication. What is embodied acting? The essence can be described simply: when the actor is aware of what is happening in his/her body, when he/she is open to the impulses of the environment, then his/her imagination and memory unclose. So it can be stated that embodied acting is a dynamic psychophysical (psychophysiological) process, during which an actor, while responding to the impulses of the environment, feels, perceives, imagines, and remembers. More investigations are needed; however, it can be presumed that the skills of the embodied acting might enable the embodiment of spectating, for, as Patrice Pavis formulates, "the audience embodies actors" embodiment' [Pavis 2014, 8]. In fact, empathy itself is embodiment.

Instead of conclusions

We can celebrate the intensity of emotional engagement, however, it should not damage or destabilize – this concerns actors as well as spectators. It is nothing about "optimistic" or "positive" art. Rather, it is about creating conditions for productive exchange between actors and the audience. The interdisciplinary research with collaboration of theatre scholars and artists

¹¹ There are quite a few descriptions what bodymind is. As Rick Kemp suggests, a holistic concept of the bodymind means the reflexive and integrated relationship between physicality, thought, emotion and expression [Kemp 2012, xv]. According to Melissa Hurt, "Bodymind refers to the actor when she works with awareness of what she feels, does and understands... The bodymind includes the actor's feelings, perceptions, mood, and somatic knowledge that continuously exchange information in a biofeedback circuit" [Hurt 2014, 9].

as well as specialists of medicine would help estimate what conditions are most favourable for effective communication between performers and spectators. It seems that the objective should be to find the ways how to re-establish the coherence in heart-brain communication of the actor as well as of the spectator. Only then can the creativity of the actor fully unfold and the sensibility of the spectator intensifies.

References

- BENNETT, Susan. *Theatre Audiences. A Theory of Production and Reception*. Routledge, 1990.
- BLAIR, Rhonda. "Image and action: cognitive neuroscience and actor-training". In: *Performance and Cognition. Theatre studies and the cognitive turn*. Ed. Bruce McConachie and F. Elizabeth Hart. Routledge, 2006, p. 167–185.
- BOGART, Anne. "Foreword". In: Erin Hurley, *Theatre & Feelings*. Palgrave Macmillan, 2010, p. ix-xv.
- DAMASIO, Antonio. *The Feeling of What Happens. Body and Emotion in the Making of Consciousness*. Harcourt Brace and Co, 1999.
- FRESHWATER, Helen. *Theatre and Audience*. Palgrave and Macmillan, 2009.
- HURT, Melissa. *Arthur Lessac's Embodied Actor Training*. Routledge, 2014.
- KEMP, Rick. *Embodied Acting. What Neuroscience Tells Us About Performance*. Routledge, 2012.
- LUTTERBIE, John. *Toward a General Theory of Acting. Cognitive Science and Performance*. Palgrave Macmillan, 2011.
- MCCONACHIE, Bruce. "Preface". In: *Performance and Cognition. Theatre studies and the cognitive turn*. Ed. Bruce McConachie and F. Elizabeth Hart. Routledge, 2006, p. ix-xv.
- MCCONACHIE, Bruce. *Engaging Audiences. A Cognitive Approach to Spectating in the Theatre*. Palgrave Macmillan, 2011.
- MCCONACHIE, Bruce. "Introduction: Spectating as Sandbox Play". In: *Affective Performance and Cognitive Science. Body, Brain and Being*. Ed. Nicola Shaughnessy. Bloomsbury, 2013, p. 183–197.
- MCCRATY, Rollin. "Heart-Brain Neurodynamics: The Making of Emotions". <https://www.heartmath.org/assets/uploads/2015/03/heart-brain-neurodynamics.pdf>
- MANCING, Howard. "To see play, read the book". In: *Performance and Cognition. Theatre studies and the cognitive turn*. Ed. Bruce McConachie and F. Elizabeth Hart. Routledge, 2006, p. 189–206.

PAVIS, Patrice. "Introduction. A Few Improvised and Provisory Thoughts on Acting Today". In: *Acting Reconsidered: New Approaches to Actor's Work. A collection of scientific articles*. Lithuanian Music and Theatre Academy, 2014.

WHITE, Gareth. *Audience Participation in Theatre: Aesthetics of Invitation*. Palgrave Macmillan, 2013.

RAMUNĖ BALEVIČIŪTĖ, PhD, is a theatre scholar and critic. She is an associate professor of theatre history and theatre criticism at the Lithuanian Academy of Music and Theatre and the head of the Department of Art History and Theory. She is also the editor-in-chief of the main Lithuanian theatre magazine *Teatro žurnalas* (the former *Lietuvos scena*). Besides scientific articles and the publications of the spread of science and art, she has published two monographs: *Henrikas Kačinskas* (2006) and *Rimas Tuminas: Theatre More Real Than Life. Play in Rimas Tuminas' Theatre* (2012). In 2013–2014, she headed the research project *Thinking Body: Acting Systems' Analysis and Integration in the Process of the Work of a Contemporary Actor* at the Lithuanian Academy of Music and Theatre.

The Theatrical Double Reflexivity Complex: How the Spectator Creates Metatheatre

ALEX CAHILL*

Abstract: “The Theatrical Double Reflexivity Complex” explores the possibility of the spectator’s presence and influence in altering the style of a theatrical production during a performance. The author focuses on African American audiences in American theatre as the primary subject of this phenomenon and claims that by incorporating their own reality into the world of the play, the spectators can force a play to become metatheatrical regardless of the actors’ or director’s initial intent. Beginning with the initial assumption of what we, as theatre artists, expect from our audience, this article explores the results of what occurs when an audience does not conform to the specific style set forth. In doing so, this article examines the engagement of the spectator as character and instigator by providing a new theory to the world of metatheatrical theory – the possibility of the Theatrical Double Reflexivity Complex.

Keywords: spectator, metatheatre, reflexivity, theatre/drama

This is an article. You, as my audience, already know that – and you expect this article to be an article. But this is also more than an article. It will argue a point, and it will impact you. But for now, it is nothing more than an article. It depends on you, my audience, to make it into something more. Similarly, a play is a play. Like this article, plays require an audience to form opinions about the pieces. But while all plays require an audience of some sort to make it a performance, what makes one play different from another? One answer is the artistic style in which the play is presented, and of the styles available, metatheatre is one of the most intriguing when analyzed for its theatrical convention.

Coined in 1963 by Lionel Abel, metatheatre encompasses a vast range of definitions. Abel’s description of metatheatre states, “Metatheatre gives [...] the stronger sense that the world is a projection of human consciousness, [...and] assumes there is no world except that created by human striving,

* University of Missouri’s Department of Theatre, e-mail: LAI522@mail.missouri.edu

human imagination.” (Abel 113) Yet, metatheatre should not be limited to this one explanation. Metatheatre also provides an experience of reality within the theatre that usually confronts the audience with a social or existential problem or question. Sociologist Erving Goffman expanded metatheatre theory when he applied theatrical terms to everyday life. Coincidentally, this adaptation of the term spurred an anti-theatre prejudice in which theorists aligned the theatre with a negative, false reality in contrast to the world’s reality.

Metatheatre or “metaplay” as employed by Abel existed long before any theorist coined the phrase in the twentieth century. William Shakespeare and Pedro Calderón de la Barca both utilized metatheatrical elements in their plays and characters to instigate dialogues and highlight certain aspects of the performance. In this regard, Abel argues that both Shakespeare and Pedro Calderón – while attempting to write tragedy – discovered a new dramatic form that included *self-consciousness*: metatheatre (151). This new form was then seen repetitively throughout theatrical history in different parts of the world. In addition to Pedro Calderón (Spanish) and Shakespeare (English), other artists that exercised this new form were Jean Genet (French), Samuel Beckett (Irish/French), Bertolt Brecht (German), and Luigi Pirandello (Italian), to name but a few. Each of these dramatists used metatheatre in a variety of ways to emphasize their commentary – usually political – on societal complications. Shakespeare’s *Hamlet* and Pedro Calderón’s *Great Theatre of the World* are considered the two classic examples of elementary metatheatre, wherein both comment on human nature and desire. Brecht and Beckett furthered the discussion of human nature through their metatheatrical Epic Theatre and Theatre of the Absurd, respectively.

Once metatheatre was recognized as a unique dramatic form in the twentieth century, theorist Richard Hornby further deconstructed metatheatre with what is known today as the *drama/culture complex*:

A play operates within a system of drama as a whole, and, concentrically, also within the systems that form culture as a whole. Culture, centered on drama in this way, I am defining for the sake of brevity as the *drama/culture complex*. The drama/culture complex [...] provides our society with a vast model for understanding reality. A play is ‘about’ drama as a whole, and more broadly, about culture as a whole; this drama/culture complex is ‘about’ reality not in the passive sense of merely reflecting it, but in the active sense of providing a ‘vocabulary’ for describing it. (Hornby 22)

In this model, Hornby creates a guideline for how drama can influence life, and life influence drama. While he does not believe that one play can alter society and its values, the feedback loop of the complex allows for

gradual change should enough plays/media discuss the issue. In order to provoke change, Hornby argues that the dramatist should ferociously attack the sociological system and therein, force his audience to examine the codes of their culture. However, Hornby was analyzing the drama/culture complex from primarily the artist's perspective. He incorporated the audience into the complex, because spectators juxtaposed the actors' reality with their element of Real reality. But the audience members arguably did not play a prominent role in his investigation of metatheatre. Hornby's theory focused more on the text of the play and its treatment of his five techniques employed by playwrights.¹ Of these five techniques, I will incorporate ceremony-within-the-play and self-reference into this article's overall analysis. Ceremony-within-the-play occurs when a ceremonious act – seen as performative – is incorporated as a subunit within the larger unit of the theatrical performance. This technique is seen in plays that integrate acts that are religious or ritualistic within the dramatic action. Self-reference is the “most extreme, intense form of metadrama” (Hornby 117) occurring when “the play directly calls attention to itself as a play, an imaginative fiction. Acknowledging this fiction of course destroys it, at least temporarily” (Hornby 103).

According to Hornby, self-reference occurs only when the play calls attention to itself as a play. Flipping this theory on its side, let us examine metatheatre from a different angle. Suppose the play is *directed* and *acted* in the style of realism, but it is *received* metatheatrically. What of it then? By examining theories which discuss the role of the audience, as well as performances which have created this particular phenomenon, I will argue that a play not intentionally defined as metatheatre by its playwright or director can become metatheatrical based on the audience's interaction during the performance. To satisfy this argument, I will first analyze the historical role of the audience, then the manifestation of the audience (specifically the African American audience) as a responsive collective group in the twenty-first century, and finally, introduce a theoretical possibility for this cultural phenomenon.

The role of the audience has been an important aspect of theatre throughout history. Ancient Greek plays were performed in large amphitheatres designed to hold thousands, and Shakespeare used “the audience's imagination to make giant leaps from the seen to the unseen, and what is more important, giant leaps to the insights [the audience would] need to play [its] part”

¹ His techniques are: play within a play, ceremony within a play, role-playing within the role, literary and real life references within the play, and self-reference.

(Simon 32). Simon's quote concerning Shakespeare uncovers a fascinating trend that has been continuous since scholastic studies on the audience began. While all theatre artists realize the necessity for an audience – "No play will live and breathe without the fuel supplied by the audience's one basic unstated yet powerful desire" (Simon 22)– the common study has constantly examined the role of the audience from the director/actor/playwright's perspective.

James Baldwin once argued, "The artist has to assume that he creates his audience and that the audience won't be there until he starts to work. The artist is responsible for his audience, which may exist in his lifetime or may never exist until long after he is dead" (qtd. in Estes). This statement holds a large truth in it. If there is no play, no audience will congregate to see it. But this balanced relationship of viewer/spectator has become muddied in theatre studies, resulting in theatre artists frequently assuming the position of Audience Creator: "by claiming the role of the actor, the performer also creates the audience" (Felner and Orenstein 28). Within this assumption, the actors have the influence or ability to "shape" the spectators into the audience they desire.

Since audiences have regularly been evaluated through the eyes of the artist, metatheatre has also been evaluated as it pertains to the artist, and scholastic theories of metatheatre regurgitate this ideology: "There is something magical about getting an audience to respond [...] even to think when you want them to think. That never happens in real life." (Simon 85) It is pellucid that this particular theorist is evaluating the results of metatheatre as it pertains to the artist – the *playwright* is forcing the audience to think what he wants them to think, a chimerical event that does not happen in the "real life." This statement still forces the audience into abiding to the world of the play according to the playwright. But if the audience *is* aware that they are watching a performance, could they not just as easily influence the world of the play?

The relationship between the actors and the audience has always existed and has been the topic of many analyses. Unquestionably, theatre is a collective experience, in which a group of spectators observe actors and "when the group sees something enjoyable, it lets the stage know and the stage responds. You can feel the charges of electricity jolting back and forth between stage and audience" (Simon 27). Simon argues the audience's basic desire is "to understand," (27) but a number of other desires exist in the spectator, both individual and collective. A desire for a connection between the audience and the actors exists, partly because audience members want to participate. As a spectator, audience members have the power to experience "otherness" in certain characters, or ally with a relatable character or situation. Each play

requires “an audience to collaborate actively in the creating of their fictions. The spectators complete, if they do not construct, these fictions, and in that – rather than in [the] complexity of ideas or systems of thought – resides what has always made American theatre engaging and exciting” (Adler 152). Therefore, every play could possess a certain amount of metatheatre, which is entirely in the hands of the audience. One example of this collaborative creation of the play’s world can be seen in certain productions with predominately African American audiences.²

African Americans have not always been a principal audience group in American theatre, but this statistic has been starting to change in recent years. During the 2007-2008 Broadway season, 6.3 percent of the audience was African American, a rise from the 3.8 percent during the 2004-2005 season. However, in the 2009-2010 season, the Broadway League reported a drop in African American attendances to 3.4 percent of theatregoers (The Make-Up of Broadway’s Audience). The 2013-2014 Broadway season reported that Caucasian theatregoers purchased 80 percent of tickets (The Demographics of the Broadway Audience 2013-2014). While these statistics do not include regional theatres, it is the only comprehensive analysis of the ethnic make-up of theatre audiences in America. Even though this report shows African Americans as one of the smaller percentages, Tamika Sayles argues, “Black audiences should feel included rather than targeted: increasing the appearance of all-black casts, reevaluating the notion that black casts are only limited to traditional casting, and dismissing the mindset that Black audiences are less reluctant to go to the theatre” (Syles). As I was only made aware of the possible alteration to metatheatre theory at a production of James Baldwin’s *The Amen Corner*, I will be using African American audiences as a case study in this essay. By no means does this phenomenon only occur in African American audiences. Their inclusion is solely because I uncovered this phenomenon with an African American audience and other scholars have made similar reports concerning this particular demographic. Any play has the potential to cause similar reactions from their audience members, but examining more than one group of spectators is too large for the scope of this initial article.

James Baldwin’s *The Amen Corner* possesses a strong sense of realism. The events that take place are relatable and standard. The opening stage directions read:

² For an in depth analysis on African American audiences and a theory of their receptive processes, see Susan Bennett, *Theatre Audiences: A theory of production and reception* (London: Routledge, 1997).

We are facing the scrim wall of the tenement which holds the home and church of SISTER MARGARET ALEXANDER. It is a very bright Sunday morning. Before the curtain rises, we hear street sounds, laughter, cursing, snatches of someone's radio, and under everything, the piano, which DAVID is playing in the church. [...] On the platform, a thronelike chair. On the pulpit, an immense open Bible. To the right of the pulpit, the piano, the top of which is cluttered with hymnbooks and tambourines. Just below the pulpit, a table, flanked by two plain chairs. On the table two collection plates, one brass, one straw, two Bibles, perhaps a vase of artificial flowers. Facing the pulpit, and running the length of the church, the camp chairs for the congregation. Downstage, the kitchen, cluttered: a new Frigidaire, prominently placed, kitchen table with dishes on it, suitcase open on a chair (Baldwin 15-6).

Although a director can choose the style for his/her specific production, on the surface this play offers scarce wiggle room to deter from the traditional fourth wall convention. Yet Baldwin's incorporation of the church services subtly reflects his "ideological and aesthetic posture: there exists an experiential reality outside of the self that can be grasped, that can be known, that must be lived" (Adler 147). This experiential reality is presented in the form of church services, which could arguably be defined as Hornby's ceremony-within-the-play and requires the audience member to be both a member and a spectator of the reality.

Intriguingly however, my witnessed performances of *The Amen Corner* as active dramaturge to this specific production were repetitively metatheatrical because of the participation of the audience. Unlike comedies when the audience laughs (singularly and separate) to the action onstage, these audiences' responded to Baldwin's play in tandem with the actions onstage, constructing a bridge between the two worlds. Although the time period was historical, it seemed to me that the men and women of the audience correlated their personal beliefs to the events onstage since Sister Margaret's church and character seemed to be familiar to many of the African American spectators. These audience members knew the songs that the church chorus sang and joined in the refrains multiple times, evidenced by the accuracy of their lyrics and tempo. Many statements made by characters throughout the play were verbally affirmed or dismissed by members of the audience. "That's right!" and "Amen!" were frequently murmured during the production, simultaneously distancing other spectators from the action onstage while bringing the world of the play into the audience for those who declared affirmations. For those spectators not participating, the singing and verbal injections into the play's progression distanced them and reminded them that they were spectators. This distance was evidenced by commentary heard in the lobby following the production. Although some

audience members noted the unique experience of their co-spectators participating in the show, others felt the injections were “rude,” “distracting,” and “took away from the performance.”³ Employing Hornby’s theory, the audience members self-referenced that this was a play by calling attention to themselves as the spectators. In this case, the audience unintentionally developed a conflicting equilibrium of metatheatre.

This equilibrium creates a unique role for the audience. Often in theatre, a director decides how he/she will “cast” the audience. The director usually initiates casting the audience when he/she envisions the style of performance for the particular text. During the process, the director asks him/herself, “Who is the audience to this production? What tools will they be equipped with upon entering the theatre?” By casting the audience, the director shapes the audience into the ideal group for his/her production and this casting will lead to the treatment of the audience by the actors. In *Mirror on the Stage*, Adler argues that metatheatrical plays “demand that the audience consciously think of themselves *as* an audience, thereby establishing a link between these works for the stage and other forms of Modernist art” (Adler 142). If metatheatre forces an audience to think of itself as an audience, the audience is still being cast. What happens when the audience consciously casts itself as a participatory audience? What happens when the audience becomes a different (or more shocking, additional!) character in the cast? I suggest considering the audience in a reverse manner to the traditional directing view: by entering the theatre, what does the *audience* do to the *performance*? Although the actors in *The Amen Corner* did not break character, detour from their lines or reference the play, the audience was able to supply an element of metatheatre because of their active participation in song and judgment. Certain members of the cast commented that these injections into the dramatic action were “distracting” while the character playing Sister Margaret greatly enjoyed the input since it made the scenes in the church feel more authentic.⁴ For the active audience members, the action onstage was “like looking in a mirror” (Cornwell and Orbe 32) to a reality with which they were already familiar.

This phenomenon could be explained by one theory in cognitive neuroscience known as “mirror neurons.” Discovered in the 1990s by Giacomo Rizzolatti, MD, mirror neurons are one possibility of why primates react to the actions of others. For example, if someone burns her hand, grimaces and quickly pulls her hand off the burner, an observer who witnesses the burning might also grimace and pull his hand away out of instinct. A continuous study

³ Author’s observation and interview, 22 February 2013.

⁴ Author’s observation and interview, 22 February 2013.

of mirror neurons would assist neurologists, neuroscientists, and psychologists to better explain empathy (Winerman), language development (Azar) and autism (Dingfelder).

Zeami Motokiyo and Richard Shusterman recognized the possibility of mirror neurons being used in theatre by focusing on the performer in dance and Noh theatre, and its possibilities in *proprioception* (Davies 193-5). Barbara Montero expands this performance theory to include spectators of dance and their mirror-neuronal reactions to watching dance performances, yet Montero and David Davies both argue that the reflexivity of the spectator requires a certain level of dance training to fully activate the mirror-neuronal response (Davies 198).

Likewise, the participation of the audience members in *The Amen Corner* required a certain level of familiarity to fully engage. If the religious setting used in *The Amen Corner* was a setting similar enough to a religious setting that encourages active engagement and is experienced daily or weekly by the spectators, those spectators could instinctively react to the setting via reflexivity. That religious settings are interactive is not a new theory. Richard Schechner explored the interactivity of leaders and followers in various religions in his analysis on ritual and performance in *Performance Studies: an introduction* (2002) and Stephen C. Finley and Torin Alexander explored the particularities of African American religious dynamics in their monograph *African American Religious Cultures* (2009). Through the similarity of the settings, mirror neurons could be one cause behind the reverse metatheatricality of the performance.

Neuroscientist Vittorio Gallese argues that mirror neurons are “one key to understanding how human beings survive and thrive in a complex social world.” He states, “It seems we’re wired to see other people as similar to us, rather than different. [...] At the root, as humans we identify the person we’re facing as someone like ourselves” (Winerman). Due to this identification of self in another and/or the neurological connection between a recognizable setting on stage that encourages audience participation in reality, it is possible that the audience members in *The Amen Corner* partook in the events due to the firing of mirror neurons. While the theory of mirror neurons is still relatively new and additional research is required to support its validity regarding humans, the basis of mirror neurons is logical and applicable to the thesis of this article.

Based on the settings and/or circumstances within the play, the African American audience in attendance created a too-realistic setting for the production. The spectators brought the play’s world into the world of the

audience. They encompassed both worlds into one reality. The audience did not attempt to believe that the action onstage was real; the audience enforced that the action onstage impacted their personal reality, thereby making the play part of their reality. The actor or director did not need to say, "We are real people. You are watching a play that corresponds to your own life, because this is my life," or "This is reality." The director wanted the world of the play recognizable to the spectators, but not calling attention to itself as a play.⁵ But the spectators inflicted their reality onto the actors' world, reversing the metatheatrical element. In this sense, the audience actually possessed the power to change the style of the production.

For the spectator to create metatheatre, two elements are necessary: active participation and spectator self-awareness. As mentioned previously, in metatheatre self-awareness is discussed in regards to the characters/ actors. But if the spectators possess self-awareness of their role in the theatre, could they also not feed into the metatheatricality of the performance? Further, participation is required in the production to enhance this awareness for both the spectators and performers, and the participation must be more involved than the traditional applause. These two factors are "ultimately, dependent on the audience providing its own frame of reference" (Bennet 178). Yet, more importantly in regards to the audience's capability in producing metatheatre lies the definition of that frame of reference – "The question posed of the American audience for the work is one that insists on audience members, collectively and individually, consciously recognizing themselves as that frame of reference" (Bennet 178). This cognitive recognition, partnered with the neurological theory of mirror neurons, allows the theatre spectator the opportunity to become fully engaged wherein the line between theatre reality and Real reality is blurred or possibly removed entirely: "Theatre audiences are giving high attention to the spectacle and, partly as a consequence, are closely involved" (Abercrombie and Longhurst 206). This fully engaged spectator is what Dennis Kennedy refers to as an "aroused" spectator. However, the creation of such a spectator in a structured performance poses difficulty in analysis because "so little evidence exists on spectator arousal" (Kennedy 173) outside of athletic or financial spectatorship. Instead, we must rely on first-hand accounts of these performances.

The aforementioned example of *The Amen Corner* is not the only instance of this phenomenon occurring. Mira Felner and Claudia Orenstein recorded more violent reactions during Amiri Baraka's *Slave Ship* at the Free Southern Theater in 1968:

⁵ Author's personal interview with director, 15 February 2013.

Slave Ship [...] enacted a history of African Americans in the United States and deliberately divided its audience along racial lines. [...] Many white audience members were so disturbed by this aggressive confrontation with history that they left at midpoint; others wished they had. [...] At many performances, black audience members, feeling empowered by the performance, joined the cast in shouting and intimidating white spectators (Felner and Orenstein 30).

Slave Ship was written during Baraka's "agitrope" phase and is symbolic and aggressive. The play's incorporation of dance, music, and minimal dialogue "create an experience that's closer to shamanic ritual than a 'traditional' European-style play" (Occupy Austin Reading Group). Arguably, based on Hornby's tactics employed by the playwright, theatre scholars could consider Baraka's *Slave Ship* metatheatrical. It includes elements that identify the text with a ceremony or ritual, thus creating a kind of ceremony-within-the-play, similar to Baldwin's *The Amen Corner*. The important distinction is the abrasive behavior of several audience members during these performances.⁶ It is possible that the African American audience of *Slave Ship* felt safe to explore their instincts and react since they were in a theatre (a "safe space"), which implicated a fallacy of safety. By doing so, the audience removed the safeguard of "This is theatre" by participating freely in the menacing actions in the play. Their involvement penetrated the Reality of the non-participating audience members with the stage reality. Therefore, nearly every play could possess a certain amount of metatheatre, since every audience has the capability of making the play metatheatrical.

The first example, *The Amen Corner*, presented a socially benign interaction with the text in which the audience participated in song and response. The second example, Amiri Baraka's *Slave Ship*, offered the violent counterpart. These samples display two opposing incidents in which the audience created a metatheatrical performance by clashing the reality of the stage with the audience's Reality of life. This cultural phenomenon has yet to be explored theoretically. Noting this absence in theatre scholarship, I would like to suggest a possible theory explaining this cultural phenomenon in twenty-first century American theatre. What is oft forgotten is that the audience, as a body, is actually comprised of multiple individual selves. The self is aware

⁶ A side note relevant to this topic is the act of audience's rioting in the theatre because of a particular performance. Samuel Hay notes a performance of Baraka's *Slave Ship* in Greenville, Mississippi, in which the audience was "ready to revolt" (*African American Theatre: An Historical and Critical Analysis* (Cambridge: Cambridge University Press, 1994), 250). However, for the purposes of this article, I want to focus instead on the audiences' actions that take place during the performance and do not halt the performance.

and knows it has been perceived as a unified mass, and therefore feels comfortable in participating in its traditional role of observing:

Most audiences prefer the pleasurable fantasy of observing without being observed. [...] Unlike real life, you – in your privileged seat – are deliciously invisible. You get your information by just happening to see it or overhear it. [...] If you realize the actors are playing to you while pretending to do something else, you're going to get annoyed [...] but notice how often the 'you' is some specialized person you are being asked to become, while the real you remains alert behind your screen of invisibility (Simon 48-9).

In some performances, the self recognizes the similarities to its reality and creates an understanding and association with the performance. Simon argues that this need for association stems from the idea that "all civilization, all our urges to perpetuate ourselves, all culture, religion, society, art, science, technology, wars, everything (including theatre), can be traced to the irreconcilable tension between the consciousness of self and the knowledge that the self doesn't last" (Simon 21). Therefore, by putting the self into something eternal (say, the world of a play – which never dies), it connects the play's existence with the existence of the self, creating a dual-existence that perpetuates the life of one by the presence of the other.

W.B. Worthen argues that a work is only complete by the entities that comprise it: "By locating the *work* in the text, [...] the 'text vs. performance' argument makes an odd eventuality possible: the unacknowledged importation of the kinds of authority associated with the *work* into the performance itself" (Worthen 15). Each performance of the work contributes to the *work* as a whole. When the self becomes intrinsically connected to the work through its relationship in a performance, it also becomes an entity in the work. By responding to the work as it occurs, the self influences that particular performance, altering the performance and thus, the existence of the *work*. By associating the self in the audience with the performance onstage, the self and the performance are both changed. This amalgamation of self and performance harmonizes with Hornby's self-reference, which argues, "If the observer's concept of self undergoes a contraction when self-reference occurs in a play, the world of dramatic illusion undergoes a displacement" (Hornby 116). Although Hornby meant that the observer's concept of self is brought into question when self-reference occurs in the text of the play, it is also possible that the audience could be the instigator to throw the theatrical world into displacement, specifically seen in the incident during *Slave Ship*.

The metatheatrical elements at work in this analysis can be described as mirrors within the production. These mirrors are specific devices used to assist the actors and audience in understanding, "This is a play." The devices can be the script, stage directions, audience placement, casting of the audience and actors' interaction with the audience. But the audience can also provide mirrors. Those mirrors could be their interaction with the actors during the performance, their reception of the production, or possibly their presence in the first place. This power given to the audience exists because "The secret power of the gaze is that it does its work on both sides of the Cartesian frame, in which the mirrored subject appears even when – in the light that blinds upon the stage as it never does the silver screen – the gaze appears to be broken" (Blau 6). To illustrate this idea, imagine there are two mirrors in every theatre, one behind the audience and one behind the actors, as seen in the diagram below:

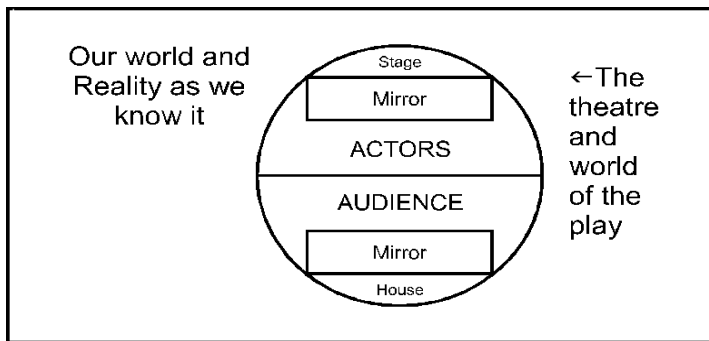

Fig. 1: The Theatrical Double Reflexivity Complex
Illustrated by author

In most plays, the mirror behind the actors is covered with drops or flats (metaphorically, of course), which symbolize that the performance is not meant to reflect its identity as a performance. In other plays like Annie Baker's *Circle Mirror Transformation*, the mirrors are intentionally incorporated into the play and frequently referenced. These plays were most likely written in a metatheatrical style. When two mirrors are paired together their reflections create an endless abyss, thereby making a consequential reality. If, in the theatre, two mirrors existed on the two back walls, the reflections would give the appearance that the entire world is consumed by the world of the stage, creating a continuous theatre world, leading to an infinite reality that is comprised entirely of the play.

The reflections of the theatre extend beyond the realms of understanding, thereby encompassing our whole world into the world of the play, leading to an endless existence of the play's world. This realization forces the audience to include their own world, Reality – as they know it – into the play's world. In most metatheatrical productions (specifically relating to Brechtian ideals), the audience is constantly reminded that they are the audience because the actors remind them. But I suggest it is also possible for the actors to be reminded that they are performing because of the constant participation of the audience. In this specific diagram, the audience knows they are the audience, because they can “see” themselves (either in the characters or setting) and judge or caution themselves. Consequently, the other non-participatory spectators are constantly reminded by these interruptions that they are part of an audience watching a play, and although they refrain from partaking, their awareness contributes to the added metatheatrical element. When the spectators force the performance into the metatheatrical realm, the actors can “see” themselves as actors because the spectators remind them that there is an audience.

This is the conclusion. Often, theatre scholarship has regarded metatheatre as a theory that explains certain elements employed by the playwright, director, or actor to consciously make the audience aware that the performance they are witnessing is a play. Richard Hornby provided five techniques the playwright could incorporate to make the play metatheatrical. Of these techniques, the most efficacious is self-reference in which the audience becomes aware of the play because the conventions in the background come into the foreground. I propose that the audience in attendance also has the power to self-reference the play by claiming their role in the world of the play as a participant, not just an observer. By participating freely in the action occurring onstage, the audience forces the Reality of their presence into the actors' reality. Sometimes, not every audience member wants to participate and the action taken by the fellow spectators jolts these audience members into awareness of the play. This divide between observers can occur when the content of the play is a) politically drastic or b) relatable to some or most of the spectators.

Audience participation, whether violent or enthusiastic, is an integral factor of live theatre. As in the cases of Amiri Baraka's *Slave Ship* or James Baldwin's *The Amen Corner*, the participation of the audience stimulated a heightened awareness amongst all members of the audience – whether participatory or not – that this performance which was initially deemed a safe fiction of real events was itself creating a new reality within the theatre. This phenomenon is teased out in Baz Kershaw's study of the theatre in ecological terms:

A riot introduces entropy into the ecotone of stage and auditorium, actor and audience, so that its edge effects become unpredictable; a riot might make or break the reputation of a play, a production, or a theatre, but the impact of its excess of entropy can hardly be ignored. Such disordered energy always poses both a threat and an opportunity to an ecosystem, as it is the source both of decay and potential destruction and of rejuvenation and potential renewal. In this sense all ecosystems have an ambivalent potential, but ecotones are especially dynamically ambivalent, and those of theatre ecologies are no exception (Kershaw 187).

In Kershaw's analysis, the audiences need to possess a certain state of unruliness to contribute to the theatre's ecosystem: "Theatrical performance is the most public of all the arts because it cannot be constituted without the direct participation of a public. [...] That is why the theatre in the twenty-first century, perhaps more than anything else, needs unruly audiences" (Kershaw 205). However, "unruly" should not only include violent audiences, but also could include those audiences that do not conform to the original intended performance style of the director or writer. It is in the presence of these spectators that theatre can find a revitalized and transformed sense of purpose: "When naughty spectators take the protocols of theatre into their own hands, so to speak, through riots and other incidents of 'illegitimate' self-empowerment, theatre ecology is often treated to a shock of renewal" (Kershaw 187).

The production of *The Amen Corner* I dramaturged and witnessed was directed in the style of realism, but received by the audience metatheatrically. Since the predominately black audience knew the songs, setting, and characters, there were verbal affirmations and singing from the audience at specific moments, adding an unintentional metatheatrical element to the realistic play. Baraka's *Slave Ship* instigated politically fuelled performances, empowering audience members to join the action onstage, thereby clashing the safety net of the theatre with the real threat of an angry mob. The realm of metatheatre is expanding and the role of the spectator should be examined as one of power and persuasion. Hornby's metatheatre discusses the ability of the theatre specifically in relation to social change, allowing this theory concerning the audience to possess sustainability. When the audience decides to actively partake in the action, they express a desire to not only understand but also engage. In doing so, the audience generates a new possibility for metatheatre, further blurring the lines between theatre and reality, and creating a new dimension in the relationship between actor and audience and a new possible role for the effervescent spectator.

References

- ABEL, Lionel. *Metatheatre: A New View of Dramatic Form*. New York: Hill and Wang, 1963.
- ABERCROMBIE, Nicholas and Brian Longhurst. *Audiences: a sociological theory of performance and imagination*. London: Sage, 1998.
- ADLER, Thomas P. *Mirror on the stage: the Pulitzer plays as an approach to American Drama*. West Lafayette, IN: Purdue University Press, 1987.
- AZAR, Beth. "How mimicry begat culture." *American Psychological Association*. (October 2005) Vol. 36, no. 9. Accessed 25 August 2015.
<http://www.apa.org/monitor/oct05/mimicry.aspx>.
- BALDWIN, James. *The Amen Corner*. New York: Samuel French, 1968.
- BENNETT, Susan. *Theatre Audiences: A theory of production and reception*. London: Routledge, 1997.
- BERGER, Peter L. and Thomas Luckmann. *The Social Construction of Reality*. Garden City, NY: Doubleday & Company, 1966.
- BERNE, Eric. *Beyond Games and Scripts*. New York: Grove Press, 1976.
- BLAU, Herbert. *The Audience*. Baltimore: The Johns Hopkins University Press, 1990.
- CORNWELL, Nancy C. and Mark P. Orbe. "'Keepin' It Real' and/or 'Sellin' Out to the Man': African-American Responses to Aaron McGruder's *The Boondocks*." In *Say It Loud!: African American Audiences, Media, and Identity*, edited by Robin R. Means Coleman, 27-44. New York: Routledge, 2002.
- DAVIES, David. *Philosophy of the Performing Arts*. Oxford: Wiley-Blackwell, 2011.
 -"The Demographics of the Broadway Audience 2013-2014." *The Broadway League*. Accessed 20 July 2015.
http://www.broadwayleague.com/index.php?url_identifier=the-demographics-of-the-broadway-audience.
- DINGFELDER, Sadie F. "Autism's smoking gun?" *American Psychological Association*. (October 2005) Vol. 36, no. 9. Accessed 25 August 2015.
<http://www.apa.org/monitor/oct05/autism.aspx>.
- ESTES, David C. "An Interview with James Baldwin." In *Conversations with James Baldwin*, edited by Fred L. Standley and Louis H. Pratt, 270-80. Jackson, MS: University Press of Mississippi, 1989.
- FELNER, Mira and ORENSTEIN, Claudia. *The World of the Theatre: Tradition and Innovation*. Boston: Allyn and Bacon, 2006.
- GOFFMAN, Erving. *The Presentation of Self in Everyday Life*. Woodstock, NY: Overlook Press, 1973.
- GROSS, Robert F., ed. *Tennessee Williams: a casebook*. New York: Routledge, 2002.
- HARE, A. Paul. *Social Interaction as Drama*. Beverly Hills, CA: SAGE Publications, 1985.
- HAY, Samuel. *African American Theatre: An Historical and Critical Analysis*. Cambridge: Cambridge University Press, 1994.

- Homan, Sidney. *The Audience as Actor and Character: The Modern Theatre of Beckett, Brecht, Genet, Ionesco, Pinter, Stoppard, and Williams*. London: Associated Universities Press, 1989.
- HORNBY, Richard. *Drama, Metadrama, and Perception*. London: Associated Universities Presses, 1986.
- JAG, Jan, ed. *Psychoanalyzing cinema: a Productive Encounter with Lacan, Deleuze, and Zizek*. New York: Palgrave Macmillan, 2012.
- Kennedy, Dennis. *The Spectator and the Spectacle: Audiences in Modernity and Postmodernity*. Cambridge: Cambridge University Press, 2009.
- KERSHAW, Baz. *Theatre Ecology*. Cambridge: Cambridge University Press, 2007.
- LEWANDOWSKI, Joseph D. *Interpreting Culture: Rethinking Method and Truth in Social Theory*. Lincoln, NE: University of Nebraska Press, 2001.
- Occupy Austin Reading Group. "Amiri Baraka, 'Slave Ship.'" Accessed 10 May 2013. <http://occupyaustinreadinggroup.wordpress.com/2011/11/18/amiri-baraka-slave-ship/>.
- PRATT, Louis H. *James Baldwin*. Boston: Twayne Publishers, 1978.
- SAYLES, Tamika. "Black Audiences Should Feel Included Rather than Targeted: What is the Theatre Industry Doing to Reach Them?" *Huffington Post* (5 August 2012). Accessed 5 May 2013. http://www.huffingtonpost.com/tamika-sayles/black-theatre-audiences_b_1739184.html.
- MAYO, Simon. *The Audience and the Playwright: How to Get the Most Out of Live Theatre*. New York: Applause Theatre and Cinema Books, 2003.
- "The Make-Up of Broadway's Audience." *In the Shadows of Broadway*. Accessed 7 May 2013. <http://www.shadowsofbroadway.com/audience-article/>.
- WINERMAN, Lea. "The mind's mirror." *American Psychological Association*. (October 2005) Vol. 36, no. 9. Accessed 25 August 2015. <http://www.apa.org/monitor/oct05/mirror.aspx>.
- WORTHEN, W.B. "Disciplines of the Text: Sites of Performance." *In The Performance Studies Reader*, edited by Henry Bial, 10-25. New York: Routledge, 2004.
- YOUNG, T.R. *The Drama of Social Life: Essays in Post-Modern Social Psychology*. New Brunswick: Transaction, 1990.

ALEX CAHILL currently serves as the postdoctoral research fellow in the University of Missouri's Department of Theatre. Her specializations include Ancient Greek and Roman drama, Shakespearean studies, and the intermingling of theatre and religion. Her publications have appeared in *Theatre Survey*, *The Shakespeare Newsletter*, and *Studies in Theatre and Performance*. Dr. Cahill's first book is currently under negotiations with an academic publishing house.

*Dramatic Space and Performer's Body, a Case Study*¹

MARINA CRISTEA*

Abstract: Mediated images alter the perception of the real, then again, they emphasize themselves in a dynamic manner arising critical attitude, for they compel the spectator to consider all the images entering his/her visual field, and to integrate them into his/her own reference system. As recorded images offer the possibility of simultaneous representation of parts of actors' bodies, an interaction between virtual images and real / optical images occurs, interaction which, whether demonstrates itself compulsory, acquires a powerful dramatic finality, since the existence of a viable relation between the stage images, either virtual or real, is a *sine qua non* dramatic condition.

Keywords: performer's body, degree of presence, subjective reality displacement, field of perception, mixed media performance, media oriented design

Consequent upon the reformation of the theatrical space in the 1960s and the validation of the poetics of the image in the 1980s, the use of digital images in staging dramatic texts - peculiar mark of "mixed media performance" (Grübel - Grüttemeier - Lethen 2001, 73; Lehmann 2006, 26, 151- 152) -, is but one of the many ways contemporary theatre succeeds to reinvent itself in its relation to reality, a reality furthermore intrinsically mediated.

Mixed media performances posit a reality whose meaning apparently eludes the spectator by reason of reorganizing his/her visual field, where

The visual field is a kind of introspective experience contrasted with the naive experience of the visual world", whereas the field of view is "a fact of ecological optics. (Gibson 1986: 114)²

¹ A previous version of this text was presented on the occasion of the 2013-2015 Prague Quadriennale Symposium "Layering Reality. The Right to Mask", October 31- November 1 2013, in Prague.

* Marina Cristea, Phd candidate at Babeş-Bolyai University, Faculty of Theatre and Television, e-mail: marinabaumgarten@gmail.com

² At page 48, see the distinction between physical optics and ecological optics, as in considering an illuminated object, a luminous body or a reflecting surface.

Mediated images alter the perception of the real: "Technology alters our perceptual mechanisms, it changes the way we see and more importantly, the way we think. (...) The external form no longer gave a hint as to its function." (Aronson 2005:46)³, whereas „the theatre is precisely that practice which calculates the place of things *as they are observed*: if I set the spectacle here, the spectator will see this; if I put it elsewhere, she/he will not, and I can avail myself of this masking effect and play on the illusion it provides." (Barthes 1977, 69)⁴ Limitation or reconfiguration of the visual field, as well as perspective cancellation, considering for instance, what Berger 1972, 18 says: "Perspective organized the visual field as thought that was indeed the ideal. Every image that used perspective proposed to the spectator that he was the unique centre of the world. The camera and more particularly the movie camera demonstrated that there was no centre. The invention of the camera changed the way men saw.", or new reference frames⁵ are possibilities multimedia technology particularly grants.

At the same time, this "new" reality emphasizes itself in a dynamic manner favoring a critical attitude towards the images thus presented, for it compels the spectator to consider all the images entering his/her visual field and to integrate them, somehow to fold them into his/her own reference system. Critical attitude usually arises when there is something that does not fit in, or when the authenticity of the object of his/her own perception becomes questionable, and he/she begins to search beyond the image „the other" reality⁶ or „the other" space⁷.

Unlike physical spaces, cyberspaces are „problematic to identify spatially", they „possess radically different properties", but they produce maybe not so radically different effects, although „their power is of a different order than that of a physical space." (Aronson 2008, 25), as a result of their lack of boundaries, dimensionality or measurability.

³ See also Crary 2001, 4: „(...) it is important to emphasize that an immense social remaking of the observer in the nineteenth century proceeds on the general assumption that perception cannot be thought of in terms of immediacy, presence, punctuality."

⁴ See also Barthes 1977, 70: "The *tableau* (pictorial, theatrical, literary) is a pure cut-out segment (...); the *tableau* is intellectual, it has something to say (something moral, social), but it also says that it knows how this must be done; it is simultaneously significant and propaedeutical, impressive and reflexive, moving and conscious of the channels of emotion."

⁵ See, for instance, Aronson 2005, 89.

⁶ Cfr. Causey 2006, 15, See also Van Den Berg 2006, 57 apud Oberender 2004, 25" Once we accept any visual representation as authentic in its own right, a new kind of space becomes open to perception: a mediated world in which the „real" space perceived through one's immediate senses is but one among many variables, which are all set in relation to one another."

⁷ See Aronson 2005, 89.

(...) the ontology of the performance (liveness), which exists before and after mediatization, has been altered within the space of technology. (...) The question of the drama is not one of representation, of the thing and its reflection, but rather of the splitting of subjectivity. (...) the combination of video and live images is a visual metaphor of split subjectivity. (Causey 2006, 16, 21 and 23)

As recorded images offer the possibility of simultaneous representation of particular spaces or of parts of actors' bodies, an interaction between virtual images and real / optical images occurs, interaction which, whether demonstrates itself compulsory – "With some notable exceptions, projected scenery, especially film and video, does not work – does not function- on the stage. (...) Unless the intent is specifically to create a sense of dislocation and disjunction (...) the placement of such technology and imagery on the stage is tantamount to carrying on a conversation in two languages." (Aronson 2005, 87) –, acquires a powerful dramatic finality, since the existence of a viable relation between the stage images, either virtual or real, is a *sine qua non* dramatic condition.

The sets for *Phaedra's Love* staged in 2006 at the Studio Hall of Arad Classical Theatre by director Mihai Măniuțiu and designer Doru Păcuraru, are a case of mixed media performance⁸, and in a lesser degree one of media - oriented design⁹, although the scenic space is configured in order to emphasize the role and function the different medial tools have during the staging.

The stage design here discussed has a twofold aspect, that of a marine monster thoracic cavity¹⁰ and that of an aircraft or submersible ambiguous interior, interior converging on the surface of a projection screen. It seems a depth structure that evolves horizontally, along a central cat walk, that together with its restricted height gives an idea of the "thermal space" (Hall 1990: 54). Nevertheless, the projection screen, whose very bidimensionality is doubled by the lack of depth of the stage, is a frame¹¹ between the world seen and the world unseen, the open-closed limit to another space¹², invisible to the spectators, whose access is permitted only by means of the images the

⁸ The video images are signed by Lucian Moga, Vava Ștefănescu and Eduard Goia.

⁹ Syntagma coined by Van Den Berg 2005, 53.

¹⁰ Possibly referring to Theseus' curse following which Hippolytus falls a prey to Poseidon.

¹¹ See Pavis 1998, 155 definition of theatrical frame, "as not only the type of stage or space in which the play is performed. More broadly, it also refers to the contextualization of the fiction represented. Frame is to be taken both literally (as a «boxing-in» of the performance) and abstractly (as contextualization and foregrounding of the action.)"

¹² "The «submedial space» as Boris Groys called it, is that space of perception which " lies behind or beyond the images present on the stage, and which becomes open to perception through the fault lines between different ways of seeing offered by different kinds and levels of imagery." (Van Den Berg 2005, 55)

periscope - camera that Phaedra maneuvers offers. But these black and white images do not describe Hippolytus' objective world¹³, rather his solitary, subjective space¹⁴, and have therefore an illicit, voyeuristic character.

What the spectator sees is not real time events or the performer's real body, but Phaedra's selection, in other words, a continuous subjective view, a „voracious" search for the «*punctum*» with apparently no regard to «*studium*». Barthes 1982, 55-56, uses the term «voracity» in order to contrast the «pensiveness» photography allows: "(...) in front of the screen, I am not free to shut my eyes. (...) I am constraint to a continuous voracity; a host to other qualities, but not pensiveness (...). Yet the cinema has a power which at first glance the Photograph does not have: the screen (as Bazin remarked) is not a frame but a hideout: the man or woman who emerges from it continues living: a «blind field» constantly doubles our partial vision. (...) yet once there is a *punctum*, a blind field is created (is divined)."

The two following terms, *studium* and *punctum*, are coined by the same, at pp. 26-27, in reference to photography. At p. 43: "Yet the *punctum* shows no preference for morality or good-taste: the *punctum* can be ill-bred.", at p. 44: "(...) the *punctum* has, more or less potentially, a power of expansion. This power is often metonymic." and at p. 51: "The *studium* is ultimately always coded, *punctum* is not." Nonetheless, for Barthes, the *punctum* is the very tangency point of the two, photography and cinema.¹⁵

Within both the stage space and the dramatic staging, the video media technology has a constitutive role, designed in order to fold the invisible spaces (whether they are subterraneous, as those "inhabited" by the singing supernumeraries, or aside, or behind the stage, wherefrom Phaedra, Hippolytus or Theseus appear), whose degree and function become perceivable as the theatrical performance evolves.

In *Phaedra's Love*, Sarah Kane reverses the original formula of the myth by role inversion: Hippolytus is the decadency in person, but in his monstrous tediousness hypocrisy abhors him, while Phaedra, vacillating between disgust and tenderness, falls prey to the passion for her step-son; her suicide is not revenge, but the only gift Hippolytus would appreciate, whereas director Mihai Măniuțiu operates both a restoration of myth's formula – for Hippolytus

¹³ An universe that other stagings of Kane's text depict, for instance, that of director James MacDonald. (see Urban 2001, 42) The correspondent "Firstspace, perceived space". (Soja 2000, 17)

¹⁴ Somewhere between the "Secondspace, conceived space" and "Thirdspace, lived space" (Soja 2000, 18, 21-22). We consider these terms as denominating degrees of the space, specific and at the same time, convertible, fluid, not determined once and for all.

¹⁵ See the quotation above, Barthes 1982, 56.

keeps his integrity, in Măniuțiu's staging, the incest is not shown, but suggested, and takes place only as a result of Phaedra's will, during Hippolytus' moments of syncope that Phaedra provokes to him by evoking Lena's name, possibly his «catastrophic», impossible love – and a transgression: Phaedra's suicide is not only a skillful frame-up, but part of a therapeutic process that helps the character definitively elude her eternally tragic destiny. We might affirm Phaedra's case is that of „the prisoner” surviving „the concentration camp”.

In her interviews, Kane confesses the impression made on her by the discussion between Roland Barthes and Bruno Bettelheim about the “amorous catastrophe” (see Barthes 1990, 48-49: “The amorous catastrophe may be close to what has been called, in the psychotic domain, «an *extreme situation*, the situation experienced by the subject as irremediably bound to destroy him»; the image is drawn from what occurred at Dachau. Is it not indecent to compare the situation of a love sick subject to that of an intimate of Dachau? (...) Yet these two situations have this in common: they are, literally, panic situations: situations without remainder, without return: I have projected myself into the other with such power that when I am without the other I cannot recover myself, regain myself: I am lost, forever.” Though first appalled by such a comparison, Kane concludes Barthes meant “the loss of self. And when you lose yourself, where do you go? There's nowhere to go; it's actually a kind of madness.” (in Urban 2001, 42-43)

Phaedra eludes tragic since she manages to make an instrument out of it: she tries to exorcise her affects by fighting instead of consuming the «image – repertoire»¹⁶ that obsesses her. We are not to forget Phaedra's mythological background, a dramatic character Euripides created, took over by Seneca and other dramaturges and poets: Zeus' nephew and Minos' daughter, Ariadne and Pasiphaes' sister, and Theseus' third wife, is a Cretan woman of royal origin, of a passionate and wild nature, that chooses the suicide both because of her searching of the heart and as a last attempt „to morally rehabilitate herself”, as Augoustakis 2007, 416 affirms in his review of Armstrong 2006.

She uses the recorded images in order to manipulate (see, for instance, the feigned suicide and the game of its alternatives, as an ironic quotation of Bazin's metaphor¹⁷) or to exorcise herself within the frame of an assisted therapy process within the strict but connive relationship patient-doctor – that consists in hypnosis, exposure, autosuggestion, pain inducing and pain confronting techniques (for instance, the reiteration of voyeuristic images), and

¹⁶ Syntagma belongs to Barthes. See for instance, Barthes 1990, 95.

¹⁷ Cinematographic image is also seen as a «fenêtre ouverte sur le monde» on account of its powerful realistic force.

pain annihilation (see the visual self-referential technique) entailed by the elimination of its very causes, at the end of her «periodic» clinical evaluations. The passion for Hippolytus is also a reverse of Theseus' absence, hence the death of both of them resolves the problem. Placed in self-defense, Phaedra has no remorse, for she chooses between being a victim by letting the passion consume her, and fighting it, even with the price of liquidating the others. She finally survives an impossible love. In Măniuțiu's staging, in the end, Phaedra drops the mask worn by an anonymous character in the prologue, another victim of ambiguous identity, or maybe the embodiment of hers or Hippolytus' twisted soul. In other terms, a double unmasking: that of the feminine nude character in the prologue and that of Phaedra, at the end of the show.

On the contrary, Hippolytus, the son of Theseus and Antiope, the queen of the Amazons, whose chastity is beyond doubt, as he devoted himself to Artemis, tries to furnish his inner vacuum, his irrepressible dissatisfaction resorting on decadent metaphors, on „imagined” but never uttered narcissistic dialogues (see, e.g., the ingenious *mise en abîme* of his anniversary, a second degree dramatic space, folded through this very device). The fact theirs is a mediated interaction reveals their impossible relationship, the communication failure caused by characters' incapacity to see beyond the image they offer one another¹⁸: at first, Phaedra can't overcome Hippolytus' image as well as the latter cannot forget Lena's. The other characters: the Doctor, Strophe, Theseus have complementary functions: the Doctor seems to use Phaedra's case, but he is not the one leading the game; similarly, Strophe and Theseus are but dramatic pretexts, whose alienation the staging suggests. Lena is the only evoked character.

On one hand, the recorded images are a distance measuring device, and on the other hand, they render the invisible relationship of the two characters, precisely, their emotional reference to one another, expressed in a manner that differs from the usually postmodernist dramatized discourse, making us ask ourselves whether the spaces the virtual images fold are but dramatic mental spaces, and not purely, always dramatic, spaces as we might consider them at a glance, if the stage box itself is a first degree dramatic space folder, whereas dramatic mental spaces are second degree ones.

Inserting recorded images in theatrical set design leads to a more nuanced configuration, richer in meanings by integrating events that take place in different spaces and moments to a single field of perception: “The

¹⁸ “(...) we are often fooled by visual experience that turns out to be illusory, an inclination generated perhaps by our overwhelming, habitual belief in its apparent reliability. Here the compensating sense is usually the touch, as we ask confirmation through direct physical contact.” (Jay 1994, 8)

space of sight is accordingly not Newton's space, absolute space, but Minkovskian event-space, relative space." (Virilio 1994, 62)¹⁹

The visual frames refer to spaces mentioned by the dramatic text (as the burning of Phaedra's alleged corpse is), spaces hidden by the stage structure or props, spaces intentionally excluded from the visual field (for instance, Hippolytus inaccessible world) or the inherent interventions, insertions or deviations from the dramatic text specific for a staging. In the black and white bitter comic anniversary episode rendered on screen as silent film cuts, camera duplicates²⁰ ironically the scenic space in a oppositional structure, the real scenic space being reproduced specularly, and fragmented, whereas the virtual one is unfolded and then re-proposed as a whole. As Causey 2006, 27, affirms: "The contrast of screen and real object (...). The linkage is to suggest that one operates at the behest of the other, not separately, or in cancellation of the other, but in a symbiotic relation; no illusion, no reality, and vice versa." These are cases in which recorded image becomes complementary, by modifying the course of the text and producing other meanings (for instance, the suicide attempts recorded versions cumulated or considered separately).

By means of recording, the effects dramatic situations nevertheless produce are enhanced. If a spectator is not in any sense a voyeur, his/her sight reaching spaces and watching gestures intended to be seen, he/she explores private spaces of characters not meant to be shared with other characters – e.g., the voyeuristic episode of Phaedra watching Hippolytus absent from the stage: on the screen is projected that part of Hippolytus' body Phaedra envisages.

Thus, spectators share with Phaedra both/either the sight and intimate space of Hippolytus, his "tactile space"²¹ (a first degree space), and/or her

¹⁹ See also, Berger 1972, 29: "The meaning of an image is changed according to what one sees immediately beside it or what comes immediately after it." and Van Den Berg 2005, 52

²⁰ Van Den Berg 2005, 58-59, identifies and analyzes four types of video camera instrumentalization in German director Frank Castorf and set designer Bert Neumann discussed productions, i.e. video camera as a surveillance, voyeuristic, research and citation device.

²¹ On distance and space perception, see also the distinction the painter Braque makes between the tactile and visual space, as Hall 1990: 60, cites "the tactile space separating the viewer from objects while the visual space separates objects from each other. M. Balint describes two different perceptual worlds, one *sight oriented*, the other *touch oriented*. Balint sees the touch oriented as both more immediate and more friendly than the sight oriented world in which *space* is friendly but is filled with dangerous and unpredictable objects (people). In spite of all that is known about the skin as a information - gathering device, designers and engineers have failed to grasp the deep significance of touch, particularly active touch. They have not understood how important it is to keep the person related to the world in which he lives."

mental images (a second degree space). These rudimentary images put in light details usually imperceptible on stage, by both spectator and actor (for instance, the way the scene representative for Hippolytus decadent behavior is filmed and the way the same situation is represented live on stage: the compressed, folded, supposed space rendered by the virtual images unfolds on stage, revealing thus also another degree of presence, that Georges Banu states as a mutual dependence between the investigations of the theatrical space and the efforts to gain the „effect of maximal presence“ which was, as Banu affirms: „Beside the variety of the spaces, in all experiences, what was searched for. Therefore, the renewal of the dramatic spaces was constantly accompanied by a rediscovery of the body.“ (Banu 2003, 11)²²

The presence of the *double* takes place through mediated duplication: the simple moment when a live actor confronts his/her mediated other through the technologies of reproduction. I propose that the experience of the self as other in the space of technology can be read as an uncanny experience, a making material of split subjectivity. (...) the inclusion of the televisual screen in performance and the practice of performance in the screened world of virtual environments constitutes the staging of the privileged object of the split subject, that which assists in the subject's division, capturing the gaze, enacting the subject's annihilation, its nothingness, while presenting the unrepresentable approach of the real through the televisual screens (Causey 2006, 17)

This staging restitutes the typical visuality of this dramatic text both by the interplay between images of real and images of feigned, virtual facts, and by the correspondence, even though not always effective, between virtual images, «image – repertoire», and feigned dramatic reality. In *Phaedra's Love*, but not only (see *Blasted* (1995) and *Cleansed* (1998)), Kane shows instead of evoking or describing (our underlining) violent actions, which enhances the visuality degree of her writing – for instance, tragic events take place on stage. Nevertheless, these virtual images appear to be more „true“, i. e., more complete, than the conventional scenic images, since they offer the viewer a twofold perspective: of watching a filmed, mediated scene and of confronting or integrating two or more unmediated scenic images²³.

If in this case, video technology is used to enhance the direct exchange between actors and audience, also its „purpose (...) serves as a unifying factor to tell stories (...)“ (Dundjerović 2009, 47)²⁴, not as a conceptual weapon. The

²² If not otherwise specified, the translations are ours.

²³ See supra, note 25, the mentioned director Mihai Măniuțiu's stagings using the virtues of multimedia technology. See also, in *Job Experiment* (2003), the references to *Kaiserpanorama* (Berlin, 1880) (Crary 2001, 135) and Duchamp's installation *Etant données* (1929).

²⁴ See also Dundjerović 2009, 48.

turning to technology of this production²⁵ deals possibly with that sense of subjective reality displacement whose grounds are to be searched only partially in the very technology of image-making. Subjective reality displacement is a *avant-garde syntagma*, defining one of the breaks and also the transition from Modernity to Postmodernity:

When the camera reproduces something, it destroys its uniqueness. As a result, its meaning changes. Or more exactly, its meaning multiplies and fragments into many meanings." (Berger 1972, 19)²⁶

References

- ANSELL-PEARSON, K., "Viroid Life. On Machines, Technics and Evolution", in *Deleuze and Philosophy. The Difference Engine*, Routledge, London-New York, 1997, 180-229
- ARMSTRONG, R., *Cretan Women. Pasiphae, Ariadne and Phaedra in Latin Poetry*, Oxford U.P., 2006
- ARONSON, R., *Looking into the Abyss. Essays on Scenography, Theatre Theory and Text Performance*, Routledge, 2005
- „The Power of Space in a Virtual World”, 23-35 in Dorita Hannah – Olav Harsløf (ed.), *Performance Design*, Museum Tusculum, Copenhagen, 2008
- AUGOUSTAKIS, A., review of R. Armstrong 2006, *The Classical Review*, vol. 57, no. 2, 2007, 416-417
- AUMONT, J., *L'image*, Nathan, Paris, 1990
- BANU, G., *Ultimul sfert de secol teatral. O panoramă subiectivă (The last quarter of century of the theatre. A subjective panorama)*, D. Voicu (transl.), Paralela 45, Pitești, 2003
- BARTHES, R., *Image – Music - Text*, S. Heath (transl.), Fontana Press, London, 1977
- *Camera lucida. Reflections on Photography*, R. Howard (transl.), Hill & Wang, New York, 1982
- *The Rustle of Language*, R. Howard (transl.), California U.P., Berkeley-Los Angeles, 1986
- BAUDRILLARD, J., *Simulacra and Simulation*, Sh. F. Glaser (transl.), Michigan UP, 1995
- BERGER, J., *Ways of seeing*, BBC - Penguin Books, London, 1972
- CAUSEY, M., *Theatre and Performance in Digital Culture*, Routledge, London-New York, 2006
- COTÉ, M., "Technics and the Human Sensorium: Rethinking Media Theory through the Body", *Theory & Event*, vol. 13, no. 4, 2010, 21-30

²⁵ For the role and uses of recorded images and media technology in theatrical and Opera productions of director Mihai Măniutu, see *Woyzeck* (2005), *Ecclesiastes* (2007), *Otello* and *The Rest* (2008), *Walpurgisnacht or the Steps of the Commodore* (2009), *Life is a Dream* (2012). (Photos and videos of the mentioned stagings are available at www.maniutiu.com/portfolio) See also Modreanu 2010.

²⁶ See also Causey 2006, 23: "The doubling technologies of mediation act as a *sparagmos*, fragmenting the subject, displaying its fabrication and remembering what is other." Or Phelan 1996,148: "Performance in a strict ontological sense is nonreproductive."

- CRARY, J., *Suspension of Perception. Attention, Spectacle and Modern Culture*, MIT Press, Cambridge, 2001
- GIBSON, J.J., *The Ecological Approach to Visual Perception*, Taylor & Francis Group, New York, 1986
- GROYS, B., *Art Power*, MIT Press, Cambridge MA, 2008
- GRÜBEL, R., GRÜTTEMEIER, R., LETHEN, H., *Orientierung Literaturwissenschaft*, Rowohlt, Hamburg, 2001
- HALL, E.T., *The Hidden Dimension*, Anchor Books-Doubleday, New York, 1990 (a reprint of the 1966 edition)
- INNIS, R.E., "Technics and the Bias of Perception: the Tacit Logic of Embodied Meanings", in *Pragmatism and the Forms of Sense*, Pennsylvania U.P. 2002, 131-166
- JAY, M., *Downcast Eyes. Denigration of Vision in Twentieth-Century French Thought*, University of California Press, Berkeley-Los Angeles-London, 1994
- KERSHAW, B., NICHOLSON, H. (eds.), *Research Methods in Theatre and Performance*, Edinburgh UP, 2011
- LASLO, M., "Un experiment pe multiple planuri - Iubirea Fedrei" ("An Experiment on Multiple Levels – *Phaedra's Love*), *Man.In.Fest*, no. 1/2007
- DE MÈREDIEU, F., *Digital and Video Art*, Chambers Harrap Publishers, 2005
- MODREANU, C., *The Ever Changing Space*, Bybliotek, Cluj-Napoca, 2010
- OBERENDER, Th., „Mehr jetzt auf der Bühne“, *Theater Heute* 4, 2004
- OURDAT, J.-P., *Cahiers du cinéma 1969-1972 (The Politics of the Representation)*, vol. III, N. Brown (ed.), pp. 189-202 / "L'effet de réel", *Cahiers du cinéma*, no. 228, 1971, 19-28
- PAVIS, P., *Dictionary of the Theatre: Terms, Concepts, and Analysis*, Chr. Shantz (trans.), Toronto and Buffalo: University of Toronto Press, 1998
- PHELAN, P., *Unmarked. The Politics of Performance*, Routledge, London-New York, 1996
- SOJA, Ed. W., "Thirdspace: expanding the scope of the geographical imagination" in A. Read (ed.), *Architecturally speaking: practices of art, architecture, and the everyday*, Routledge, London-New York, 2000, 13-30
- SLOREDIJK, P., *Critique of Cynical Reason*, M. Eldred (transl.), Minneapolis, 1987
- THIES LEHMANN, H., *Postdramatic Theatre*, K. Jürs – Munby (transl.), Routledge, London, 2006
- URBAN, K., "An Ethics of Catastrophe: The Theatre of Sarah Kane", *PAJ (A Journal of Performance and Art)*, vol. 23, no. 3 (Sept. 2001), 36-46
- VAN DEN BERG, K., "Scenography and Submedial Space: Frank Castorf's *Final Destination America* (2000) and *Forever Young* (2003) at the Volksbühne Berlin", *Theatre Research International*, vol. 32, no. 1, 2006, 49-67
- VIRILIO, P., *The Vision Machine*, J. Rose (transl.), Indiana U.P., Bloomington, 1994

MARINA CRISTEA is an *Accademia di Belle Arti in Rome (Scenography)* graduate. She holds a BA in *Classical Philology* and is a PhD candidate in *Theatre Studies*, "Babeş-Bolyai" University Cluj-Napoca, with a research theme in *History of Ancient Theatrical Performance (Greek tragedy)*. She is a freelance visual artist.

Mug shot: Transraciality – Analysing the race with race in art

ANDREI TIBERIU MĂJERI*

Abstract: In the present article, we analyse the concept of transraciality in art, especially within the performance field, by connecting it with its firestorm manifestations in the modern society. Is transraciality the new frontier in public acceptance or just pure utopia? We'll talk about our findings by focusing on some pertinent artistic examples and social behaviours. Focusing on the *homo fignens* as a part of the postmodern deconstruction of the human being, we reach the expending community of persons with mixed background and their interactions with art or the public perception. Hollywood stereotypes, cultural appropriation methods, race bending, collage and pastiche, all form the list of tools we operate with. Furthermore, we'll focus on media cases involving raw definitions of transraciality, also on some pop culture examples, trying to connect their meanings with theatricality and the theatre/the stage phenomenon. The anxieties of a potential post-racial society put pressure on how we want to be seen by others and break the rules of racial differentiation. The enormous growth in self-consciousness opens a gate for alterity/otherness.

Keywords: transracial, post-racial, skin, theatricality, identity, bovarism, cultural appropriation

In this article we analyse the concept of *transraciality* in art, especially within the performance field, by connecting it with its manifestations in modern society. We won't resume our strategy to a philosophical or psychological point of view, but we will try to draw permanent analogies between "trans" and "race", interrogating the significance of this hypothetical artistic subject. Seeking the meanings of *transracial* we encountered a certain insufficiency in dictionaries, the word being absent in most of them, while those trying to define the concept resume to "something/someone *extending across two or more races.*"

* PhD candidate at Theatre and Television Faculty, UBB, Cluj Napoca; e-mail: andrei_majeri@yahoo.com

This definition clarifies some aspects of our exploration, but explains neither an attempt to change *race* or fight against its features, nor the genesis of this phenomenon. We immediately started thinking about children born in mixed families, but usually that is called diverse racial background, not *transraciality*. To enhance our research across this fresh concept, we open a large field of raw subjects, and try to pave the way for future investigations by *altering* the meanings of *transraciality*.

Race is just a subtype of the only living human species, the *Homo sapiens*. In all subclasses, there are a few differentiating characteristics, due to the exposure to different climatic factors over the years and the separate evolutions of the four main races: Caucasian, Mongoloid, African and Austronesian. Many sub-races are catalogued, and also the majority of possible mixtures have names in different languages: Mulatto, Zambo etc. Thus, a *multiracial* person is not a rare sight in our world these days and has his right place in society. Research in heredity / genetics regarding the races shows us that intellectual capacity, life expectancy and social skills are not influenced by the racial factors.

Post-racial behaviour and the artist

To begin with, we will focus on some media cases involving *transraciality* and later we'll try to translate its meanings by connecting them with *theatricality* and the stage. Is *transraciality* the new frontier in *public acceptance*? There have been a few examples of "race bending" throughout the past centuries and the majority were seen as eccentricities, but never has such a strange pursuit on changing the deeper meanings of the skin emerged as in present-day. The anxieties of modern man put pressure on how we want to be seen by others, transforming many physical characteristics. An enormous growth in self-consciousness opens a gate for alterity/otherness. Claude Levi-Strauss says that: "Identity always gives birth to alterity." (Levi-Strauss, Claude, 2014)

In the beginning of the 20th century, human attraction towards the exotic was right away put into display (the human zoos, some circus companies etc.), but today is evaluated from a racial point of view, or the *politically correct* one. Race is not seen as an oddity anymore. Nonetheless, our common sense concerning race is often blurred by some kind of ancestral order that puts it into question. The fascination towards "the other" makes people act wrong, assuming the risks of *racial metamorphosis*. *Race*, to some extent, gives human beings the impression of the possibility of choice (a false one), or of a birth-given "right" (see all the fascist and racial ways of thinking). Adjusting race is a utopia and a danger.

Race segregation has seen some of its worst manifestations during the last centuries, leading to personal tragedies, civil rights transgressions and trans-national racist views. Nowadays, after the end of slavery, the eventual collapse of the Apartheid, the famous anti-segregation actions in the USA (the *Selma to Montgomery Marches*, the *Greensboro sit-ins*) or the great leading figures such as Martin Luther King Jr., our society has brought *race, racial speech and social injustice* into attention to a remarkable extent. World has entered a *post-racial* society, not yet cleansed from racial views, still working its way through some conventional beliefs.

Famous people with mixed race backgrounds, let's call them *multiracials*, have been taken much more into consideration by the general population over the last few years. Therefore, the term entered mainstream vocabulary, reforming the concept of identity. Writer Alexandre Dumas (the father) could be an earlier example, but nowadays we have many more: Barack Obama, Mariah Carey, Alicia Keys, Lenny Kravitz, Keanu Reeves etc. This is not a remote community, but an expanding one, encompassing singers, actors, public figures and even presidents. Its development is due to our modern society's freedom of moving, or, as some think, to the freedom of choosing whom to love and have children with. Even the concept of family is now regarded through the lens of feelings, not through the social class criticism of the past centuries. The presence of more numerous mixed-race families is a natural course given by all of the above. But there can never be a 50/50 attitude towards *biraciality/multiraciality*, due to the exposure to *racial ambiguity*, living for a longer period in one of the communities, or due to cases of intolerance. Studies suggest, in the majority of examples, discrepancies in one direction, a more pro-white, pro-black, pro-(x race) attitude. A child is always extra-captivated by one of his parents' race, thus his inner racial balance becomes uneven. Somehow, he "acts" to a higher degree one of the two races, thus staging his own life, by choosing "who" and "what" to play. Compared with an actor, he is a very special breed, having the possibility of choosing his masks and making its own images of reality.

In media, pop-star Michael Jackson was and, to some extent, even after his death, still is suspected of turning himself into a white man. Nonetheless, he always stated that he suffered from *Vitiligo*, a dangerous skin condition. Jackson's disease was subject to many conspiracy theories, due to his growing popularity. After becoming whiter every day, he grew obsessed with surgical interventions in order to pursue a more Caucasian look, and, as we all know, that didn't turn out very well. The nowadays pop stars obsessed with bleaching their skin represent another observable and hot topic. Take a look at, for

example, Beyoncé in 2005 and in 2015. We will find a far whiter woman, as in many other cases (Rihanna, Nicki Minaj etc.), and the number is increasing. Does their work in artistic environments diminish the gravity of their skin bleaching actions? The stage has its own set of rules, the ambiguity being one of the strongest weapons of any performer. Believing to be cursed by geography, some choose to emphasize part of their racial features to reach goals. Others take into consideration provocative body actions to promote themselves and their most beloved works. Stage actions are forms of survival, artists producing with their exposed body, gender, or with the epidermis regularly causing transgressions.

The Dolezal case

The newspapers' titles at the beginning of the 2015 summer were filled with Rachel Dolezal's name, a white woman who reached the top of the hierarchy in the *National Association for the Advancement of Colored People* in the USA, while willingly posing as a black woman. The social media have immediately burst into flames after the leak of this awkward case scenario. The woman stated that she identifies herself as black female and defended the manner in which she acted by making public her past in a mixed race family. But, as we can see in the picture beneath, she is a pure Caucasian woman that voluntarily got a lot of tan. Of course, her life was strongly influenced by black culture, having step siblings and an African-American husband and studying at the historically black Howard University. Many consider that the Dolezal case should be marked as a diagnosable condition, based on her tendency to absorb something not rightfully hers, and spending almost an entire career hiding the fact that she was a white person. Dolezal freely distorted the truth about her race because it furthered her job-related goals, doing that by claiming *transraciality*, her black face probably emerging as a hidden ego. All this can be understood by need to be accepted inside a community, not by a strong inner feeling or some kind of a birth right.

Throughout history, people have identified with other *races* only if they have socialized with their representatives for a large period of time or grew up in a specific racial environment. In some cases, due to adoption, people may feel more comfortable around those of a distinct race. They usually have mannerisms or paradigms of speech that we have been socially expecting to belong with another race. The mixed-race families bring a large amount of struggles for a child, Rachel Dolezal playing the card of the dysfunctional family she allegedly had. If we assume Dolezal is right and *transraciality* becomes a modern social revolution "hit", or a possibility for anyone, we must also assume attainable and justified differences between races. And that is, first of all, a racist statement in an apparently racial free world.



Fig. 1: Rachel Dolezal, NBC NEWS, 2015

One's sense of self has a lot of power becoming artistic by cross-fertilization between art and life. Gesturing the body, self-fetishization and performing the skin is a step further in the artistic field, increasing awareness of identity. Commenting on Plato's tough views on art and its apprehension of reality, David Novitz asserts that the general opinion about art and reality, but not the true one, is:

"Art [...], is about the real world, refers to it, and so must be different from it."
[Novitz, David, 2001: 69]

We also think that the real world comments on art or is changed by it. The Dolezal case could be just a first real example (definitely not a positive one) in what will become a fashion very soon by translating life into art and performing racial transgressions.

Mimesis and cultural appropriation throughout the world

The dilemma of dealing with this *transracial* moral crusade is quite a burden, racial disguise having so many embellished shapes. What about South Korean women trying to get more European features by adjusting their "imperfect" features or African women ramping up their Caucasian characteristics to get

married faster? More and more, human mentalities challenge their limits regarding the race, this topic being influenced a lot by the media. The rise of surgical interventions to “slightly” change racial features is going through a real boom nowadays. Countries like South Korea have an alarming increase in the numbers of people changing their racial features. People of the 21st century living in developed countries know how they want to act socially and are willing to take risks by playing with the limits of their allegedly judgmental environment.

Able to develop meaning, art has always had an eye for racial inheritance and all its chains of interactions. Some great artists, like Paul Gauguin, were fascinated by other races, and their works were influenced by a large amount of ethnic elements. Nonetheless, that was the beginning of the 20th century and not the year 2015. Still, Gauguin did not claim to be Tahitian. The nowadays artistic speech has to learn how to be moderate and respectful - or is art completely amoral? We can be inspired by the things that separate us, not being allowed to bend the rules too much and steal the characteristics of “the other”.

People find solace in the arms of role-playing, a few in a safe environment like the theatre stage, others in real life. Performance artists mix those two things together, bringing on stage or in a museum real (non-fictionalized) persons, interacting with them, or just allowing themselves to be interrogated in a number of artistic actions. They try to be relevant to the challenges of the modern world. *Race*, in terms of what we do and how we act, is essentially a social construct, but definitely there isn't such a thing as being born in the wrong race. Even theatre's tutelary god, Dionysus, a hybridized character, half-man, half-god, was called *Eleutheros* (the Liberator), promising his followers a kind of freedom by lying and pretending to be another, thus by acting. Theatricality is based on role-playing, impersonating and acting. The Michael Jackson case, or, to some extent, even the Dolezal situation, remind us of the bovaristic behaviour, seeing bovarism as:

It is a conception of oneself as other than one is to the extent that one's general behaviour is conditioned or dominated by the conception; *especially*: domination by such an idealized, glamorized, glorified, or otherwise unreal conception of oneself that it results in dramatic personal conflict (as in tragedy), in markedly unusual behaviour (as in paranoia), or in great achievement.
(<http://www.merriam-webster.com/dictionary/bovarism>)

The *mimesis* is strongly infiltrated in the bovaristic way of living and in the actor's craft/art. The bovarist character conceives their self as another, the actor being a moving identity in his quest for stage characters, used and professionalized

to be a *homo fingens*. The main difference between the two types is that the bovarist fakes his identity for himself, the actor doing it for others (*to be* versus *to act/to represent*). Having a fictionalized destiny, the actor/artist has a critical empathy towards the object of his imitation, being saved by theatre from his latent bovaristic behaviour, thus: "The will of the bovarist is a damaged one." (Cuibus,-2011)

In addition, to a certain degree, *transraciality* merges with *cultural appropriation*. Therefore, we ought to bring up this secondary subject into discussion. For some, it seems as if only people of colour have a unique culture, while white people always try to steal it. The inherent advantages white people have due to skin colour are a hot topic in our society. Nadra Kareem defines *cultural appropriation* as:

Taking intellectual property, traditional knowledge, cultural expressions, or artefacts from someone else's culture without permission. This can include unauthorized use of another culture's dance, dress, music, language, folklore, cuisine, traditional medicine, religious symbols, etc. It's most likely to be harmful when the source community is a minority group that has been oppressed or exploited in other ways or when the object of appropriation is particularly sensitive. (Nadra Kareem Nittle, racerelations.about.com)

If we take a look at Hollywood stereotypes, we'll find many *cultural appropriation* methods in that environment, some morally objectionable. The Acceptance Speech at the 45th Academy Awards of Sacheen Little-Feather, sent there by Marlon Brando to reject the prize on his behalf, is a famous example of boycotting a ceremony in protest of the treatment of Native Americans by the movie industry. But Sacheen often goes by the name Maria Cruz and she is, surprisingly, a *multiracial* person, with Native American and European ancestors. Thus, her presence at the Academy Awards as an "Apache" was just part of the truth. Anyway, that moment was of significant importance for how Native Americans were seen on TV and in movies in that period. In Marlon Brando's powerful statement, the pop music industry immediately saw the opportunity to make a music hit, therefore Cher had a number one song that same year, called *Half Breed*.

Preserving culture does not mean keeping it away from others, but being able to make it our own and apply it in different contexts. This signifies teaching it and sharing it with those who are not familiar with its features. The dominant white culture from the western world takes Black, Latino, Indian and many other ethnic backgrounds as an opportunity to steal.



Fig. 2: Backstage at the 1973 Oscars: Sacheen Little-feather holding the speech Marlon Brando had asked her to give. Associated Press
The singer Cher in her Video "Half Breed", 1973

But culture, and furthermore skin cannot be owned, not by art, not by pop culture and surely not by society. Taking bits of "ethnic" behaviours doesn't mean white people are the only ones that mix up everything else. To hijack someone's cultural background is to pretend it is the way you truly are, to take it from the real context and transform everything for your own personal use, by destroying fundamental characteristics and keeping only what serves you. Thus, *transraciality*, as Rachel Dolezal sees it, is even more dangerous than *cultural appropriation*, because it pretends it's a birth right. Eduardo Arroyo sets the limits of the *appropriationist technique* in art history:

But when did artists first apply this appropriationist technique? If we take a generous look back into the past we shall discover that in one way or another, artists have always appropriated the work of others, that of their contemporaries and, of course, that of their predecessors, as summed up by Eugenio d'Ors in his famous assertion that "in art, what is not tradition, is plagiarism." (Arroyo, Eduardo, 2009)

TRANS beyond race

If people believe they need to identify as a certain ethnicity in order to be allowed to adopt aspects of that culture, no wonder some start to think of themselves as *transracial*. It is not hard to imagine why an insecure person

would start seeing *transraciality* as a good way to be accepted in society. Still, unlike *gender identity*, *racial and cultural identity* depends on where and how we are raised.

Talking about *transraciality* makes us immediately think about *transsexuality*. The two terms are significantly contrasting. People who identify as *transracial* shouldn't be compared to those who label themselves as *transsexual*, as racial perception and identity are in fact subject to social learning and not to physical characteristics. Scientists say genders have slightly different brains, thus being sexually dimorphic. Those who identify as another gender typically have differences in their brains, in the regions associated with sexuality. The cerebrum of a *transgendered* person resembles more that of their identified gender than the one they were born with. Breaking gender barriers is something we tend to put in the post-modern blender of our society. Going back to theatre and the performance arts, they seem the perfect environment to break any barrier. *Transgender* characters have claimed the stage and came there to stay.

The issue of *transraciality* could easily be fixed if people were more encouraged to safely explore multiple cultures, without feeling constricted to their own. Instead, they should not need to identify themselves with a different ethnicity in order to adopt traditions and lifestyles that fascinate them, and thus giving birth to very strange situations in public perception. We believe it is wonderful to maintain a strong connection with the culture you were raised in, especially while being exposed to a stronger and more dominant one, but this should not turn into cultural segregation. For a diversified Europe/America, with fundamental characteristics that are driven by diversity and freedom, trying to transcend race is very inappropriate. This also applies to the rest of the world, to various degrees. Most traditions fail to maintain their original significance anyway, even inside the community that created them. A varied environment is even more dangerous for their possible loss, and thus some cultural boundaries are to be kept.

Questioning the possibility of transraciality in art

Could *transraciality* be accepted in society/art? It is already present in our communities, trapped between conservative beliefs. If black persons take on mannerisms that society deems as Caucasian, could we call that *transracial*? However, in the middle of a group structure, there are daily changes in the self-centered models and almost anything could be broken. Humans tend to *mimic* behaviours they like, thus bringing the issue of a natural state of

theatricality, something present from children in the most remote communities, to the upper classes of western societies. People are allowed to act, as long as their actions don't harm other persons. The *transracial* self could be made in a collage technique or even by pastiche. In the famous book "*The moustache of La Gioconda*", Eduardo Arroyo perfectly defines the differences between collage and pastiche, something we find of significant importance in our thesis in which we analyze the race on race in art:

So, what is the difference between collage and pastiche? Simplifying greatly, I would say that collage is synthetic, constructive and positive (in other words, it is a technique of production), while pastiche is analytical, destructive and negative (in other words, it is a way of unmaking what has previously been made). In point of fact, I could have avoided listing these antithetical differences between the one and the other if, simplifying the issue even more, I had limited myself to affirming that collage is a mean of artistic creation, while pastiche is simply an annulment-relativisation of art by means of the greatest of modern resources-irony. Likewise, making the issue more personal, I could perhaps make the problem even clearer by pointing out that collage was invented by Picasso, while pastiche was invented by Marcel Duchamp. In spite of the reductionism I have employed to settle the issue at stake, I hope it is clear to all that collage is a technique while pastiche is a stance. (Arroyo, 2009)

The ever increasing volume of racial related topics is partly due to a liberalization of speech. Our world has its future tied up with beauty and powerful images in this profound aesthetic time we live in. *Corporeality* (manifestation of the body) is perpetually changing, and the public perception is always drifting in many limbos. *Transraciality* interrogates the artist's behaviour and how he could benefit from a reconsideration of the body, for a better collective perspective in audiences. To take a leap from the body of the performer to the public and back is to focus on the roughness of art and its major goals.

For example, fashion is dominated by white models, in both men and women clothes areas. Even in Asia, the majority of "big" fashion weeks are overshadowed by white figures. The nature of values is relative, making *transraciality* a possible option in arts and in the artistic logic. Fashion has always broken the rules of sexes and now is starting to break those of *race* by hybridizing cultural references. Japanese girls called "sweet Lolitas", mixing up Victorian clothes, geisha traditions and the so-called "cute kitsch" are famous examples. The contemporary Afro-centric fashion promoted first by the TV icons of the 90's and now brought up by the African born designers make a significant impact. The *Duro Dress* and the contemporary *Sapeur* characters

mix up traditional European fashion taste with African history. Ambiguity is pushed to its limits by make-up and clothing. We hardly identify genders nowadays, maybe tomorrow *race* will be something difficult to recognize.

Returning to stage (an almost mythical space with its own special laws), is *transraciality* something to be explored within this scheme? Examples of non-Caucasian racial features among the famous theatre plays are very rare. Othello is almost every time played by a white actor with brown make-up. Not every country has an abundant black population, and therefore not a large amount of black actors. What about non-gypsy stage actors acting gypsy characters in a stereotype manner because it is “cool” and fun? The situations in which mocking the races and their cultural baggage is a main goal are a heavily used subject by playwrights, spreading angst in those hurt by these actions. Also, in pop culture, the *cultural appropriation* is something that drives artists to rather peculiar and shameful situations. We remember Cher’s video of *Dov’è l’amore* (Italian title translated: *Where is the love*), with Spanish flamenco dancers “obviously” based in an Iberian space.

It brings to our mind one of the most well-known theatre examples of the past decades: Peter Brook’s multi-ethnic *Hamlet* from the 90’s, in an “exotic” period for the great theatre makers. Today, the newly casts, for example, in the UK, where it is recommended to have a mixed race theatre company, are a questionable and debatable subject. We don’t think we could just erase racist behaviour by mixing up racial features in art and pretend it’s enough. Is the *white guilt* in so many American plays a true belief of the average American? After the abundance of racist shootings in the USA in the past few years we assume that is false. Nonetheless, racial justice and equity could find their avatars on stage in the embodiment of the performer.

Theatricality is a form of survival; nevertheless, when wrongly used, it becomes deadly. Examples of behaviours involving *bovarism* are close to the pathological area. Theatre must be careful with its overused race “thing”. Many acted unlawfully by making it a *crash test dummy*, and not really focusing on the emotional part of a potentially strong subject. Others tried to legitimize their inner self and militated for whatever right they feel appropriate, saying freedom is freedom no matter what. Now, we go back to the eternal subject of theatre prevalence: politics or aesthetics/story?

Critics talk about provocation; however, who’s provoking who? Wounds in a society’s heart are not easily healed, the way we used to behave being corrupted for so many years. The big wave of slave-themed Hollywood movies does not win any race with racial issues. Even though the initial shockwave has been diminished, a person like Rachel Dolezal will always put the blame in her options on a rightful “heartstorm”, doing more harm by comparison with the movies.

In this paper, putting aside the reality of living examples, we are concerned with public responses to contemporary artworks that comment, interpret or draw upon racial symbolism, which have stirred up reckless passions. The bloody field of art's evolution goes far from a moral doctrine and is often surpassed by an artist unique judgment, or its inner stimulations.

For centuries, the white face of the actors was considered the basics of role-playing in theatre. Is there an evolution in the aesthetics of the theatrical face/body? Beyond the ethical problems of *transraciality*, to neglect or to praise the colour of the skin in performance arts is a free and yet not enough debated field. By exploring it, everything could turn out to be a sublime catastrophe, with *transraciality* becoming an over the top subject, or, like in the case of sexual freedom, will somehow find its timing and perfect way to get free without any "artistic" help.

Globalization and the need to perform and to be seen

Basic terms in Ethics and Aesthetics (the two appearing often together) are drifting like continents. Words, like people's imagination, never end their games, and where can one find a more appropriate playing field than theatre? It seems time is tuning out on the "fair", Caucasian, upper class performer, and the new publics want more "awkwardness"/normality on the stage, even though that is just one of the many mirrors of the world and the years we live in, jeopardizing almost everything we know about art.

Hollywood has relaxed its rules on casting over the years, Broadway and West End did the same, but what about the more traditional ways of making theatre, let's say the Eastern European rule of the director? Great directors in this part of the world are used to working with 100% white distributions, and when working in Western environment, they tend to use the same rules of the "exotic" or the "ethnic". We can put the blame on the majority of "big plays" that are Caucasian-centred, or the aesthetics of each director. But the racial point of view is still a strong one there. Globalization is seen by some as a possible threat to compact cultural mediums and the way people in those groups were thought to craft their art. Today, artists are judged by their working process, critics trying to find any potential exploitation methods. The *politically correct* policy grows in speech power and hides all these behaviours in shallow waters, never going to the more profound realities, let's call them *corporealities*.

What can we say about a very American artist like Robert Wilson, coming from a racially diverse society? His work is mostly done in Europe, a less blended racial community, his theatre being focused on image, not on the author or the text. In the majority of the American mainstream stage the author is the king. One of his particular theatrical features is that his actors' faces are

always white. The “deadly beauty” imagined by Craig and perfectly put into practice by Wilson does justice to any community with these mask traditions coming from the *Commedia dell’arte* or the Japanese *No* theatre? Surely it doesn’t. A better immersion of actors with a diverse racial background into the mainstream stage could come from a better knowledge of community theatre, or an abundance of new plays focused on mixed race families (a developing reality nowadays).

Theatre is, above all, about the human condition. On the other hand, some accept pure aesthetics, regardless of the artist’s care about *racial* problems. Those who played most with cultural appropriation and racial exchanges in their theatre work are Ariane Mnouchkine and Eugenio Barba. Their anthropologic reference points and statements could be, nowadays, interrogated by the arguments and the critical exposure of *transraciality*, in its hybrid limits or its war with identity. We must interrogate different types of theatricality to find the kind of spectatorship *transraciality* could address.

The very well-known and controversial British performer Stelarc operates a radical criticism of the pure human corporeality, the French artist Orlan accomplishing even more on this path. Stelarc’s work with his body versus the virtual realities of our days has challenged some of the most profound racial features, biased towards genetics. Orlan has gone further with her dangerous surgeries trying to resemble famous works of art, and thus changing her Caucasian appearance. Some people say we could objectify almost everything on stage, *transraciality* becoming a risk-taking topic in the quest for modern ways of fictionalizing the biography. If we zoom in this way of reasoning, we could see that over the past decades gender topics have become mainstream and less captivating for the public, as also happened with nudity on stage. Spectators want fresher subjects with new ways of showing them, topics that create a state of sublime discomfort. Howard Barker says (about literature) that people tend to react badly to great works of art in their first encounter. Could we apply that in performance arts?

The spectatorship nowadays. Changing the ways of theatricality

Analysing the young categories of audience, the spectators nowadays want to be provoked - the same persons “stolen” incessantly by movies or the internet. We suppose that people who choose to anxiously go to theatre, still want a rougher touch from the artists in front of them. Could performance craftsmen find in the raw subject of *transraciality* something valuable to put in their work?

Going “*far from the madding crowd*”, if we could say so, an artist could invent a personal micro-system in which he chooses freely the visual singularity he uses in his works. Someday, in the near future, regardless of how *transraciality*

will still be seen socially, performance arts, an even the more traditional theatre phenomenon will somehow focus on this subject and find a dramatic way of putting it on stage.

The *significant other* in this artist-*transracial* person relationship deserves a place in performance arts, even for a short amount of time, just enough for him to have a point in the witness stand. The tender and lacerating performer is long dead. Many generations fought for the right to have a voice and stood up to the excessive prejudice, and we should agree hearing the strangest of artistic voices, even though some might sound 100% crazy. The Dolezal case is sensitive to so many communities because she is not a dummy wax woman, but a rather empowering figure trying to find her true self using lies. The way in which Rachel Dolezal appropriated another identity is part bovaric, part ludicrous, thought that the Bovaric, if put in the right environment, could have theatrical meaning.

It is our misguided social construct of race that puts us all in the position of justifying and identifying *what* we are as opposed to *who* we are. In visual arts, many contemporary artists challenge *hybrid identity* in their work. Complex notions like *post-racial* appear in the artistic environment. The mainstream pop culture evolved in parallel with the visual arts field, but had the almost exact struggles. White rappers are no longer a strange thing (Eminem is white and he's one of the most famous) and race is used to sell commercial hits, as in the case of Michael Jackson, a person we already analysed. But still, that's a long way from how coloured people were treated many years ago. Racial commercials, so often used during the first half of the 20th century, showed us, for example, how soap could whiten the skin (image below).



Fig. 3: Two racial vintage commercials from “Black kids in vintage commercials” collection of Tim Urban

In the painting of the more recent years, one of the most powerful black voices, and an important figure of *transracialism* was Robert Colescott. In the 1997, Robert Colescott was selected to be the first African-American representing the USA at the Venice Biennale, where he brought paintings of figures with reversed racial features, strong political statements mocking black stereotypes. He brought laughter in his works, reinterpreting many famous creations done by his “whiter” predecessors.



Fig. 4: “Eat Dem Taters”, by Robert Colescott, 1975, Photography credit: Fred Scrutin
 “Natural Rhythm”, by Robert Colescott, 1976, Collection of Robert and Lois Orchard

Nayland Blake is another artist that has become a great example of humorous interpretation of race. In 2001 he appeared in a video with artist AA Bronson. They both had their faces covered with chocolate (Blake) and vanilla (Bronson). The two men had a very long kiss as the colours blended. They showed how in a hypothetical love environment one could dissolve any possible distinction between “black” and “white”, cosmetic and superficial marks put on race.

Race creates discomfort if used in some particular ways. But, as we stated before, discomfort can be the mark of a great artistic achievement. The “default ethnicity”, the white race, is also a big part of the *post racial* concept. It has become an interesting subject for artists in search of artistic extremities and extremes. As the figurative painting has had a revival in the last years, the face, regardless of race, has come back into painting. The looks into the Caucasian inheritance is large, because ethnical neutrality doesn’t exist. Adrian Piper’s works on *otherness* and *racism* are living proofs of the permanent fight against racial

behaviour, by constructing a cultural critique of skin stereotypes and acknowledging the legacy of slavery. For example, she stated in one of her controversial video installations from 1988 that white Americans might have some black blood mixed up in their veins, but her paradigms met objections from both critics and the general public.

Personality is created and recreated by others, those who, if we believe Sartre, are also our hell. This paradigm of biblical proportions in which people are allowed to mix their racial features brings only debauchery and insecurity. It also announces a change in the *dramaturgy of the body* by denying *personality* and creating puppets. Analyzing its effects in theatre shows us the changes in perceiving *transraciality* and how it should be performed. The phenomenon becomes exposed and we ask ourselves: could we talk here about a special type of spectator? When does *transraciality* become a special formula of *theatricality* and in what ways does it take the theatre into the future of performing arts? Could it change anything in our society or just bring a racial apocalypse?

The transracial behaviour is strongly present in nowadays music. We talked about bleaching actions of many pop stars and about Eminem's success in rap music, the greatest example in the recent years being Amy Winehouse, with her 50's black female diva appearance. She used many black related features and created a distorted apparition that won the public. Some say Iggy Azalea does the exact opposite, in a racist way of merging American Southern black features into her music. If it's not harmful to use *transraciality* to express one's creativity, we should allow its entrance in art.

In conclusion, *transraciality* exists in normal life and in all art fields, making its presence seen and accepted. It is a part of the postmodern deconstruction of the human being, the land where you can play with borderline personalities. We'll have to wait and see how *transraciality* will affect arts and society in the near future by focusing on a new *no man's land* that some call a *utopia of identity*.

References

Prints:

- ARROYO, Eduardo, (2009), *The Moustache of La Gioconda*, Museo de Bellas ARTES de Bilbao/Museo Nacional Centro de Arte Reina Sofia
- BISHOP, Claire, (2012), *Artificial Hells: Participatory Art and the Politics of Spectatorship*, Verso London. New York
- CUIBUS, Miriam, (2011), *Efectul de culise, Teatralitatea ambiguității și ambiguitatea teatralității*, (English: *The Backstage Effect. The theatricality of ambiguity and the ambiguity of theatricality*), Casa Cărții de Știință, Cluj-Napoca

- HUIZINGHA, Johan, (1970), *Homo Ludens*, New York: Harper
- LEVI-STRAUSS, Claude, (2014), *Toți suntem niște canibali*, (English: *We are all cannibals*), Cuvânt înainte de Maurice Olender, Traducere de Giuliano Sfichi, Polirom, 2014
- MALIȚA, Liviu, (2010), *Extremele artei*, (English: *The extremes of art*) Editura Accent, Cluj-Napoca
- MODREANU, Cristina, (2014), *Utopii Performative, Artiști Radicali ai scenei americane în secolul 21*, (English: *Performative utopias. Radical artists of the American stage in the 21th century.*), Prefață de Marian Popescu, Humanitas, București
- NOVITZ, David, (2001) *The Boundaries of Art, A Philosophical Inquiry into the Place of Art in Everyday Life*, Revised and Enlarged Edition, Cybereditions
- ȘEVȚOVA, Maria, (2010), *Robert Wilson*, (Romanian edition), Traducerea din limba engleză: Odette Kaufman-Blumenfeld și Oltița Cîntec, Fundația Culturală "Camil Petrescu", Revista *Teatrul azi* (supliment), Prin Editura Cheiron, București
- UBERSFELD, Anne, (1999), *Termenii cheie ai analizei teatrului*, (English: *Key terms of theatre analysis*), Traducere de Georgeta Loghin, Institutul European

Online publications:

- NITTLE Kareem, Nadra, (2015), *What Is Cultural Appropriation and Why Is It Wrong?* [Online], Available: <http://racelrelations.about.com/od/diversitymatters/fl/What-Is-Cultural-Appropriation-and-Why-Is-It-Wrong.htm>, July 15th 2015
- SMITH, Roberta, (2009) *Robert Colescott, Painter Who Toyed With Race and Sex, Dies at 83*, [Online], Available: http://www.nytimes.com/2009/06/10/arts/design/10colescott.html?_r=0, July 20th 2015
- STELARC, (2015), <http://www.stelarc.org/July24th2015>

Images and videos:

- RACHEL Dolezal, CBN News, (2015), <https://www.youtube.com/watch?v=3B24Bbsf3U4>, viewed July 18th 2015
- SACHEEN Little-Feather, Academy Awards, (1973), [Online], Available: <https://www.youtube.com/watch?v=2QUacU0I4yU>, viewed July 19th 2015
- CHER, "Half Breed" video, (1973), [Online], Available: <https://www.youtube.com/watch?v=Z6E98ZRaU1s>, viewed July 19th 2015
- Black kids in vintage commercials, Urban, Tim, [Originally posted August 2013. Updated June 2014.], *Creepy Kids in Creepy Vintage* [Online], Available: <http://waitbutwhy.com/2013/08/creepy-kids-in-creepy-vintage-ads.html>, viewed July 20th 2015
- "Eat Dem Taters", by Robert Colescott, 1975, http://archive.newmuseum.org/index.php/Detail/Object/Show/object_id/3482, viewed July 21st 2015

ANDREI TIBERIU MĂJERI

“Natural Rhythm,” by Robert Colescott, 1976, Savannah Morning News- Collection of Robert and Lois Orchard, St. Louis, Mo.

<http://savannahnow.com/accent/2009-02-14/jepson-center-showcases-robert-colescotts-provocative-paintings#1>, viewed July 20th 2015

Cher, Video Do’ eL’amore,

<https://www.youtube.com/watch?v=4AzWb951iZo>, viewed July 23rd 2015

DOLEZAL, Rachel: ‘I Definitely Am Not White’, NBC Nightly News,

<https://www.youtube.com/watch?v=3B24Bbsf3U4>, viewed July 24th 2015

ANDREI TIBERIU MĂJERI graduated in 2012 in theatre directing at the Faculty of Theatre and Television of the Babeş-Bolyai University and obtained his MA degree two years later in the same institution. Currently, he is a theatre director and a PhD candidate. Măjeri’s creative research interests include group-theories, gender studies, adaptations of classical plays and acting techniques. He has directed Euripides, Beckett, Witold Gombrowitz, Saviana Stănescu etc. His works are productions of Cluj-Napoca National Theatre (*Pandora’s Box* by Katalin Thuroczy), Bucharest National Theatre (*Organic* by Saviana Stănescu – winner of the 2014 9G/ New Generation program) or Turda „Aureliu Manea” Theatre (*Ivona, the Princess of Burgundy* by Witold Gombrowitz). His shows have traveled to festivals (*Organic* at FEST-FDR Timisoara and *Ivona, the princess of Burgundy* at FITN Arad). He is the winner of the 2015 contest for young directors of Craiova National Theatre where he will direct *AnticUpdate* by Elise Wilk.

The battle for the neuron's wings

RALUCA BLAGA*

Abstract: The following study uses as its starting point the ancient battle between philosophy and theatre and takes as a road companions its two most famous protagonists: Plato and Aristotle. Taking a close look at their writings, I found not only an answer considering their battle for knowledge, for the encirclement of the spectator's mind, but also the traces of one 'predecessor' of neuroscience – Aristotle. Informed by John Onians's theories regarding neuroscience, art and history, and also adding neural plasticity as an ingredient, I've built my own personal (sup)position regarding catharsis, which I see as a two-fold experience/process - an emotional catharsis and a reasoning, reflexive catharsis.

Keywords: neuroscience; mirror neurons; catharsis; neuroarthistory; sentimental catharsis; reasoning, reflexive catharsis.

Once upon a time there were Plato and Aristotle and had they never existed, we would not have debated or painted. One stands on one side of theatre, the other, on its other side. And in times gone by, they carried a great battle.

But was it truly a fight in which they used aesthetical, ethical and philosophical weapons? Or, was it actually about the resultant force - the force that came out after the collision between a human activity and a science built from an ensemble of concepts and ideas? I'd rather hedge my bets on the latter. Not only I hedge my bets, but I use neuroscience¹ and neuroarthistory² as my gambling chips.

The battle revolves around two main directions: to prejudice or to envelop the spectator's soul. This is, in brief, the battle for the neuron's wings, the neuron that flies on the sky guarded by the spectator. The sky that once

* PhD Lecturer at University of Arts Tirgu-Mures, e-mail: raluca.balan@gmail.com

¹ Neuroscience has its roots in the ancient past of humankind, but, with the development of technology, it has received new meanings.

² Neuroarthistory is a concept developed by John Onians in his book *Neuroarthistory From Aristotle and Pliny to Baxandall and Zeki*, Yale University Press, 2007.

imagined by Raphael Sanzio's in his *The School of Athens*: Plato, his *Timaeus*, in one hand while the other points the sky, and Aristotle, his *Ethics* in his hand, aiming his forefinger at the ground. Sky always bordered by catharsis. That means: battle for the lucidity of ideas, or for pity and fear inherent in mimesis.

Reading their works, I wish I had the infinite power to transcend time and space, and offer them an fMRI (functional magnetic resonance imaging) device. This way, perhaps, Aristotle could have detected more accurately Plato's conceptual fear. This way, perhaps, Plato could have argued more compellingly against Aristotle's ideas concepts of pity and fear. Passing through space and time, I wish I had the power to visually and auditory record the first theatrical gatherings of Ancient Greece, those events started at dawn and finished at sunset, in order to experience the force that theatre inscribed on the faces of those first fifteen thousand spectators. Or, at least, to cast an eye over those dithyrambs, poetry and tragedies born out of Plato's mind³, before his encounter with Socrates.

But maybe, I can gain a part of that immeasurable power while reading Edith Hall's *The Theatrical Cast of Athens. Interactions between Ancient Greek Drama and Society*. In this case I won't need snapshots or cinematographic tricks, but only the simple act of reading: "Agave made an impression on one mother, who killed her own three-year-old son after dreaming that she was a Bacchant (...)" (Hall 16).

Socrates suggested that his son Lamprocles could control himself in the face of his mother's abuse by remembering that her insults and threats were no more real than those exchanged by actors (*hupokritai*) in the tragic theatre; there was a contradiction between her acted behaviour and her true stance towards her son, whose best interests she had at heart (Hall 27). "So were Athenian lawsuits. If an Athenian woman was indicted for murdering her husband, it created an opportunity to claim that she had been acting out the role of Clytemnestra" (Hall 28).

"(...) the children whom Epictetus observed, around the end of the first century ad, pretending to be figures in tragedies as well as wrestlers, gladiators, and trumpet-players" (Hall 25).

Here are just a few snapshots and, this kind of snapshots are desirable for every theatrical author. The force exerted by the spectacular event was (might be?) enormous. No wonder the fight was (is it still?) tooth and nail.

All the above examples are governed by the same key-word: *to act*.

³ See Laërtius, Diogenes, *The Lives and opinions of Eminent Philosophers*, literally translated by C.D. Yonger, M.A., London, George Bell and Sons, 1901, p. 114.

A mother takes her child's life, after she has a dream filled with stage scent.
A son shows emotional intelligence, intelligence gained after watching a stage pattern.

Someone is trying to back out of a criminal act by arguing stage processes.

Children play and their game's innocence comes out of the encounter with stage actions.

Someone watches an action, it gets engraved in their mind, and this event gives birth to a new action, action based on a previous on a stage pattern.

Movement.

Motere.

Drama.

*Action*⁴.

Theatre.

I allude here to the first meaning of this concept.

Could action drive someone to ... knowledge?

While reading Aristotle and Plato, it seems to me that the same set of words comes out almost obsessively from their writings. Just that the first is situated on one side of the action and movement, and the latter on the other side of the thought which carries the action.

The sound of Plato's soul seems to have come out of Hades, out of the Idea's world, out of The Form, the absolute, out of genuine truth. For the Greek philosopher, the material, and by default art - the copy of the material - does not bring out purification. Only the thought, that is to say the intellect, which can rise up to true knowledge, is the one that can touch the truth, and therefore, purification - "namely parting the soul from the body as much as possible and habituating it to assembling and gathering itself from every part of the body, alone by itself, and to living alone by itself as far as it can, both now and afterwards, released from the body as if from fetters?" (Plato, "Meno and Phaedo" 54). Once this condition reached, or once in Hades, near the Gods - a place obviously aimed for lovers of wisdom, one will touch what is "Just itself" (Plato, "Meno and Phaedo" 52) "Beautiful" (Plato, "Meno and Phaedo" 52), "everything that is unalloyed" (Plato, "Meno and Phaedo" 53), "pure encounter with wisdom" (Plato, "Meno and Phaedo" 55), "Equal itself" (Plato, "Meno and Phaedo" 63), "the beautiful itself as it always is, one of a kind, by itself with itself" (Plato, "The Symposium and the Phaedo" 39). And the soul that travels from one body to another, from the dead to the living, from the living to the

⁴ See Patrice Pavis, *Dictionary of the Theatre - Terms, Concepts and Analysis*, Translated by Christine Shantz, Preface by Marvin Carlson, University of Toronto Press Incorporated, Toronto, 1998, p. 112.

dead, learns how to rationalize through recall and never through senses. Near someone who has built such a cognitive system, a system where one can obviously hear "philosophy (...) the greatest music" (Plato, "Meno and Phaedo" 46), someone who deals with "a kind of illusion" (Plato, "Meno and Phaedo" 56) (that is to say copies of the copies, that is to say movement, that is to say action, that is to say theatre) doesn't belong here. And this *doesn't belong here* might even get dictatorial tones throughout actions such as 'expelling' from the ideal citadel of that theatrical craftsman, who constructs goods that don't satisfy the necessary. And because of that, theatrical craftsman, who is a "lover of opinion" ("The Republic of Plato" 161) and not a "lover of wisdom" ("The Republic of Plato" 161), finds inspiration in myths, these myths must be selected and cut, so that one deals only with stories in which "the god's works were just and good" ("The Republic of Plato" 58), because the soul "full of confusion" ("The Republic of Plato" 69) and painted through imitation, 'haunts' the one who listens or watches. Moreover, "none of the craftsmen fabricates the idea itself" ("The Republic of Plato" 278), therefore, by means of imitation, they can't touch the truth, nor the reality, nor wisdom.

Let us get back to one of the quasi-statements made before colliding with Plato's philosophy:

Could action drive someone to ... knowledge?

O my friend, be persuaded by me, and hear the Delphian inscription,
"Know thyself"

SOCRATES: And self-knowledge we agree to be wisdom?

ALCIBIADES: True. (Plato, "Alcibiades I")

Philosophy and wisdom move the thought's action towards knowledge. But are they the only ones? What about theatre – that enemy on whom Plato aims his wise arrows?

On the other side of movement, on the other side of theatre, one finds the more 'pragmatic' Aristotle. In his writings, movement and action seem to be those tools used by the Greek philosopher in order to argue rationally. For an instant, let's listen, in a literary manner, to his voice: "In most of these cases the soul appears not to act or be affected separately from the body, for example in the cases of being angered, being emboldened, desiring, and perceiving in general. Thinking seems most of all peculiar to soul (...)" (Aristotle, "De Anima" 27).

Soul, then, has to be a substantial being in the second way, as the form of a natural body that has life as its potency. But this kind of substantial being is being-fully-itself; so soul is the being-fully-itself of such a body (Aristotle, "De Anima" 48).

For the Greek philosopher, theatre seems also to be in a close relation with the action. And, to theatre, he devoted two books. Unfortunately, the only book that survived and reached us is the one about tragedy; the other one, about comedy, lost itself in the footsteps of time; maybe, as Umberto Eco⁵ suggests, it was helped to lose its track by the lovers of the new wisdom – Christianity.

First, in a literary manner, and then 'scientifically', in order to understand better the old "quarrel between philosophy and poetry" ("The Republic of Plato" 290), let's take a close look at the enemy's features: Jorge, the character in Umberto Eco's novel, describes theatre's (in this case comedy) monumental force: This book would have justified the idea that the tongue of the simple is the vehicle of wisdom (Eco 280).

Aristotle, while analyzing imitation, also talks about a similar power: "The cause of this again is, that to learn gives the liveliest pleasure, not only to philosophers but to men in general; whose capacity, however, of learning is more limited. Thus the reason why men enjoy seeing a likeness is, that in contemplating it they find themselves learning or inferring (...)" (Aristotle, "Poetics").

My analytical steps have led to what I was suggesting at the beginning of this article, is at stake: the sky bordered by catharsis - the battle for the neuron's wings, neuron that flies on the sky guarded by the spectator.

Before moving on to the following step of my analysis, let me unchain, for a short while, Aristotle's voice fettered in the chains of the past: "As was said before, perception involves being moved and undergoing something, since it seems to be some kind of alteration" (Aristotle, "De Anima" 58).

Maybe if Aristotle would have been more accurate in clarifying theatre's enormous stake – catharsis – tones of critical ink wouldn't have been poured away trying to clarify these *alterations*. Catharsis, the pity and fear elicited in the spectator, feelings meant to be purged; "psychological and moral enrichment" (Pavis 416), "the communicative value of aesthetic experience" (Bălan 76) associated by Hans Robert Jauss with the same catharsis; "(...) clarification (or illumination) concerning experiences of the pitiable and fearful kind" (Nussbaum 391); "The degree to which the spectator can enter into the life upon the stage, adjusting his own feelings to what is portrayed there" ("The Essential Moreno" 48); the catharsis-dream, in Anne Ubersfeld's opinion – "There is imitation of people and their actions, while the laws that govern them appear, in that imaginary world, to be suspended. This is catharsis (...)" (25).

⁵ In this sense, see the literary version of how the second book of *Poetics* loses in the history's fog in Umberto Eco's *In the Name of the Rose*.

And all this chorus of ‘cathartic’ voices, with its infinite lines and columns, could go on singing, if I wouldn’t stop these voices and place them in their own theoretical box. And the critical glance (but let’s call it, for now, orientated towards science glance) sees a new box: beautifully arranged, one can find inside neuroscience and neuroarthistory.

At this point I almost obsessively hear in my mind Peter Brook’s voice, a voice also heard by Giacomo Rizzolatti and Corrado Sinigaglia and used as the opening line in their book entitled *Mirrors in the Brain*:

Peter Brook commented that with the discovery of mirror neurons, neuroscience had finally started to understand what has long been common knowledge in the theatre: the actor’s efforts would be in vain if he were not able to surmount all cultural and linguistic barriers and share his bodily sounds and movements with the spectators, who thus actively contribute to the event and become one with the players on the stage. (Rizzolatti IX)

Until clarifying with definitions what mirror neurons are, let us hear John Onians’⁶ words; Onians seats Aristotle in the front row and watches all his theoretical endeavor using neuroarthistory’s lenses. The new field ‘invented’ by Onians with all its components sounds like this:

Neuroarthistorians exploit all the tools used by other art historians, but they also use an additional tool, neuroscience, to help them to understand all aspects of the making and viewing processes. Today there is so much new knowledge in this field that our understanding of art can be transformed. (Onians and Fernie)

And there is no wonder that Onians chooses Aristotle to be the first philosopher analyzed in his study – it is adequate just to remember the Greek philosopher’s emphasis on movement and action. Therefore, like with Onians, I also see in Aristotle the predecessor of the discovery of mirror neurons:

While for Plato the mind is the divine within us, for Aristotle it is a material thing and something which we share with the rest of nature. Aristotle is unashamed of treating man as an animal, and this enables him to appreciate the role of nerves in our inner life. (...) it allowed Aristotle to understand something of the working of ‘mirror neurons’, that is the neurons that help us to understand and imitate the movements of those we observe. He rightly noted how if we feel or express an emotion, we can communicate it much more effectively. (Onians and Fernie)

⁶ Reading the articles published online on their Facebook page by Tate London, I’ve discovered, after I have started to study about movement and action in Plato and Aristotle’s writings, the already published theories assumed by John Onians in his *Neuroarthistory: From Aristotle and Pliny to Baxandall and Zeki*. Because his perceptions were prior to mine, I’ve chosen to assign him a well-deserved area in this study.

But what are mirror neurons?

Using the fMRI procedure (functional magnetic resonance imaging), in area F5, part of frontal motor areas, Rizzolatti and his team discovered, first in the monkeys, a set of neurons that “became active both when the animal itself executed a motor act (for example, when it grasped food) and when it observed the experimenter doing it. These neurons were recorded in the cortical convexity of F5 and were named *mirror neurons*” (Rizzolatti and Sinigaglia 79-80). After a while, the experiments and procedures concentrated also on the humans, revealing for the scientific, and also for the sensible world, the fact that: “the activation of Broca's area reflects the typical behaviour of mirror neurons. Moreover, the experiment by Buccino *et al.* shows that the mirror neuron system in humans includes large portions of the premotor cortex and the inferior parietal lobule as well as Broca's area. It also provides evidence that the mirror neuron system is not confined to hand movements and transitive acts alone, but also responds to mime” (Rizzolatti and Sinigaglia 79-80). The premotor cortex:

(...) receives inputs from the posterior parietal cortex, an area important for spatial orientation. These anatomical features, taken together, suggest that the premotor cortex plays a role in orienting the body and readying the postural muscles for forthcoming movements. (...) the premotor cortex also helps select movement trajectories. (...) The premotor cortex is also involved in cross-modal sensory integration (...) the premotor cortex plays a role in integrating visual and tactile input. (Rosenbaum 75-76)

Regarding the inferior parietal lobule we can stress that areas 39 and 40 “correspond to the inferior parietal lobule (the angular and supramarginal gyri). These areas in the dominant hemisphere function in relation to reading and writing as higher integrative areas for language. This area is part of the posterior speech area. In the nondominant hemisphere, these areas relate to our concepts of visual space” (Jacobson and Marcus 203). As for Broca's area, it: “...is essentially a continuation of premotor cortex and can be considered a specialized motor association area with regard to the tongue, lips, pharynx, and larynx” (Jacobson and Marcus 382).

Therefore, all these areas and structures which have been activated when the mirror neurons were discovered prove that:

We do not need to reproduce the behavior of others in full detail in order to understand its emotive meaning, just as action understanding does not require the actions to be replicated. Even if they involve different cortical circuits, our perceptions of the motor acts and emotive reactions of others appear to be united by a mirror mechanism that permits our brain to immediately understand what

we are seeing, feeling, or imagining others to be doing, as it triggers the same neural structures (motor or visceromotor respectively) that are responsible for our own actions and emotions (Rizzolatti and Sinigaglia 190).

At this point of my analysis, it is enough to take a look at volumes authored by Bruce McConachie, *Engaging Audiences. A cognitive Approach of Spectating in the Theatre* or the volume authored by Stephen Di Benedetto, *The Provocation of Senses in Contemporary Theatre* (and these are just two titles from the numerous about this subject) just to confirm that the collision between neuroscience, mirror neurons and theatre has been argued.

As Bruce McConachie states in the introduction to his book, the encounter between theatre and cognitive science might help us understand better the way in which the public reacts while watching a theatre performance - and this is just one side of the 'story'. As he stresses in the introduction, this kind of theoretical endeavor could be useful also for "academics who teach theatre history, dramatic literature, dramaturgy, and performance courses in acting and directing" (McConachie 6). McConachie takes as his road companion case-studies (performances of well-known plays) and his examples cover the theatre's journey from Ancient times (McConachie takes as a 'starting point' Sophocles' *Oedipus the King*) to present-day (in this case, the analysis is following Caryl Churchill's *Top Girl*), without leaving aside performances based on plays written by Shakespeare, Chekhov or Tennessee Williams. When colliding with theatre, cognitive science might 'annoy' semiotics and semioticians - just to offer one example. But, as McConachie states, we should probably take into consideration the fact that

audiences do not combine (...) millisecond images into signs and read them as part of a semiotic process. Nor will most spectators step back from their involvement in the flow of the scene to make deliberative conclusions about her condition. Rather, most viewers will directly experience Yelena's exhaustion, irritation, and embarrassment through their mirror neuron systems and also get a sense of her vanity as she enjoys the effect of her beauty on the men. This empathetic process is mostly automatic, but the kind of awareness it produces lodges in memory and is easily brought into consciousness. (McConachie 6)

Using the latest discoveries in neuroscience, Stephen Di Benedetto analyzes what 'buttons' might be used by theatre creators in order to offer the viewers a memorable experience. His theoretical steps move inside the matrix that contains elements which trigger our attention (such as light, space, movement) and probably, more importantly, help us stimulate our brain: "it is this process of triggering uncontrollable involuntary responses

that is of most interest to any discussion of how we can account for the role of sensation in communication, perception, and theatrical expression. If we understand how this happens, then we can understand its power and how we can harness it to create a powerful theatrical experience. Theatre practice can help train neural preferences" (Di Benedetto 8).

Let me get back for a few moments to the words that started these pages, I mean the great battle of the Antiquity. I would like to insert, for a short while, a new contemporary element – the Italian theatre director Romeo Castellucci, who stated that "the spectator's encephalon is interesting here, not his soul (that comes later)" (Castellucci, Castellucci et. al. 36). If I would have had the immeasurable power to offer Plato and Aristotle a functional magnetic resonance imaging device, their point of interest would have been similar to Castellucci's. Somehow those two great philosophers 'sensed' the discoveries of the second millennium and, maybe, this is the reason why the debate was so fierce. After all, as I have tried to see the nature of this battle, it seems to me, after long research, that everything was nothing more than a very well-orchestrated 'marketing strategy' that was supposed to present in front of the Athenian public the winning product – philosophy or theatre – as the two boxes that contained knowledge, truth and real.

Once again, what comes to my mind is Plato's conceptual fear, hidden deep in his soul. And I picture him, as Socrates did before me, sitting in the middle of the ancient Athenians when Agathon won the public's appreciation, together with "more than thirty thousand witnesses" (Plato, "The Symposium and The Phaedo" 5), spectating his eyes on Oedipus' tragedy. And, I picture Plato, filled with expelling thoughts when, right in front him, Iocasta confesses the old crime to her husband / son: "As for the child, it was not three days old / When Laius fastened both its feet together / And had it cast over a precipice" (Sophocles 48). And maybe, at that precise moment, Plato remembered the Delphian inscription and he himself confronted with the true knowledge of the Athenian people, those people who, sometimes, 'deposited' their children on the edge of precipices. Perhaps Plato was also referring to this kind of myths that were supposed to vanish from his ideal citadel.

Coming back to theatre's force, a force exerted at its beginnings (it suffices here to remember Edith Hall's examples), I can't help but ask those two questions from the beginning: is the force exerted by the spectacular event still enormous? Are we still engaged in a tooth and nail fight between X and Y? And let me ask another question: is catharsis still experienced?

Using as a starting point my own theatrical experience, as an informed spectator, and rolling down the theatrical events I've witnessed, I have built my own personal (su-p)position regarding catharsis. With Aristotle's words in

my mind: "Now sensory imagination, as has been said, is present even in the unreasoning animals, while deliberative imagination is present in the reasoning ones (...)" (Aristotle, "De Anima" 96), temporary, I reclaim my belief (is it a belief full of wisdom?) in the existence of an emotional catharsis and in the existence of a reasoning, reflexive catharsis.

My assumption doesn't expel the simultaneous or the separate presence of the two cathartic branches on the neuron's wings, be it mirror or not. On the sensory side (emotional catharsis) I place Hideaki Kawabata and Semir Zeki's neuroscience study, which proved very scientifically that when I examine paintings (their case study): "... the orbitofrontal cortex, which is known to be engaged during the perception of rewarding stimuli, was active, and it was more active when viewing a beautiful painting. The motor cortex was also active, becoming more active when viewing an ugly painting, as it is with other unpleasant stimuli, such as transgressions of social norms, and with fearful stimuli, including scary voices and faces, and anger" (Gazzaniga 232). In the same area of the cathartic square, I deposit a second study, *Activation of the prefrontal cortex in the human visual aesthetic perception* (Cela-Conde et. al.), which proved me that "that when something was judged beautiful, there was more activity in the left hemisphere" (Gazzaniga 233).

On the reasoning side (reasoning, reflexive catharsis) I place neural plasticity "the functional properties of neurons and the functional architecture of the cerebral cortex are dynamic, constantly under modification by experience, expectation, and behavioral context. (...) Plasticity has been seen under a number of conditions, including functional recovery following lesions of the sensory periphery of central structures, perceptual learning and learning of object associations, spatial learning, visual-motor adaptation, and context-dependent changes in receptive field properties" ("The MIT Encyclopedia of the Cognitive Sciences" 598).

Having arrived at this reflexive point, because the emotional sensation born from the neuroscience's discoveries was absorbed a long time ago, I can't end before revealing a psychic phenomenon induced by a physiologic stimulation felt when I encountered with neuroscience, Plato and Aristotle: if I would have the immeasurable power to bring in the same art gallery Aristotle, Plato, Damien Hirst, Marcel Duchamp and Marina Abramović, I would bet my mirror-soul on that exact place where those five would sit. Before revealing their position, I will stress some of these works of art features.

Marcel Duchamp is associated with conceptual art, ready-made and probably the most important re-action of his art is connected with the fact that he managed to displace the tone from the aesthetic perspective to the idea itself. His

famous *Fountain* (a urinal – of course, with a title bellow - displayed in a space dedicated exclusively to art) raises questions such as what is art, what's its goal, but as Will Gompertz, I believe that Duchamp thought: "(...) the role in society of an artist was akin to that of a philosopher (...). An artist's job was not to give aesthetic pleasure – designers could do that; it was to step back from the world and attempt to make sense or comment on it through the presentation of ideas that had no functional purpose other than themselves" (Gompertz 10).

In *A Thousand Years*, Damien Hirst uses materials such as "glass, steel, silicone rubber, painted MDF, Insect-O-Cutor, cow's head, blood, flies, maggots, metal dishes, cotton wool, sugar and water" (www.damienhirst.com) to create a work of art that speaks about cycles of life, death, humanity: "It consists of a large rectangular glass case measuring approximately 4 meters long by 2 meters high by 2 meters wide – with a dark steel frame. At the center of the case – acting as a divider – is a glass wall into which four fist-size round holes have been drilled. On one side of the divide is a white cube box made out of MDF that looks like an oversize dice, except that all sides are marked with only a single black spot. In the middle of the floor on the other side of the glass partition lies the rotting head of a dead cow. Above it hangs an insect-o-cutor (the sort of ultraviolet light-cum-electrocution device seen in butcher's shops). In two opposing corners of the glass case are bowls of sugar. To complete the piece, Hirst has introduced flies and maggots. The result is something approaching a biology tutorial, a teacher's aid for demonstrating how the life cycle works: fly lays egg on cow's head, egg turns into maggot, which feeds off cow's decaying flesh before hatching into a fly, which then eats some sugar, mates with another fly, lays some eggs on the cow's head, gets zapped by the insect-o-cutor (taking on the role of an apparently indiscriminate God), falls onto cow's head where the now-dead fly becomes part of the decaying organic matter that provides a diet for the newly hatched maggots" (Gompertz 372).

Damien Hirst's *A Thousand Years* has features comparable with those of Duchamp's works. Once again we meet a "philosopher". Regarding *Rhythm 0*, Marina Abramović states the rules: "There are 72 objects on the table that one can use on me as desired. I am the object. During the period I take full responsibility" (qtd. in Richards 87-88). Among those 72 objects, the spectators could use: "a pistol, an axe, a fork, a bottle of perfume, a bell, a feather, chains, nails, needles, scissors, a pen, a book, a hammer, a saw, a lamb bone, a newspaper, grapes, olive oil, a rosemary branch, a rose and other things" (Richards 88).

As Mary Richards argues: "the performance took place in the Studio Morra, Naples in the six hours between 8 p.m. and 2 a.m. As a consequence of her performance choices, Abramović left herself open to invasion and even abuse;

this was precisely the point. The work is constructed through the interaction of the spectator with the objects and her body. How the spectators took up the opportunities presented to them certainly revealed something of the dynamics of group psychology where a collective presence may anonymize individual action and decision-making. As such, exposing herself to this group situation was potentially a more dangerous situation than setting out the same scenario for a one-to-one encounter because responsibility for actions is shifted from the individual to the collective with group members encouraging each other to push the boundaries and experiment with the objects on offer" (Richards 88).

All these being stated, I suppose Plato would approve of Duchamp's *Fountain* and Damien Hirst's *A Thousand Years*, and, Aristotle would allow himself be overwhelmed by pity and fear while watching at all those 72 objects handled during Marina Abramović's performance of *Rhythm 0*.

References

- ARISTOTLE. *De Anima*. Translated, with Introduction and Notes Mark Shiffman. Newburyport: Focus Publishing R. Pullins Co., 2011.
- ARISTOTLE. *Poetics*. The Internet Classics Archives. MIT. Web. July 26 2015.
- BĂLAN, Raluca, *Adaptations of tragic in contemporary dramaturgy* (doctoral thesis, defended at University of Arts, 22nd of June 2012).
- CASTELLUCCI, Claudia, Romeo Castellucci, Chiara Guidi, Joe Kelleher, Nicholas Ridout. *The Theatrae of Societas Raffaello Sanzio*. London&New York: Routledge, 2007.
- CELA-CONDE, Camilo J. et al. *Activation of the prefrontal cortex in the human visual aesthetic perception*. NCBI. NCBI, Web. July 26 2015.
- DI BENEDETTO, Stephen. *The Provocation of Senses in Contemporary Theatre*. London and New York: Routledge, 2010.
- ECO, Umberto. *The Name of the Rose*. Translated from the Italian by William Weaver, New York: Warner Books, 1984.
- GAZZANINGA, Michael S.. *Human. The Science Behind What Makes Us Unique*. New York: Harper Collins, 2008.
- GOMPERTZ, Will. *What Are You Looking At*. New York: Penguin, 2012.
- HALL, Edith. *The Theatrical Cast of Athens. Interactions between Ancient Greek Drama and Society*. Oxford: Oxford University Press, 2006.
- JACOBSON, Stanley, Elliott M. Marcus. *Neuroanatomy for the Neuroscientist*. New York: Springer Science, 2008.
- KAWABATA, Hideaki and Semir Zeki. "Neural Correlates of Beauty." *Journal of Neurophysiology* 91 (2004): 1699-1705.
- LAËRTIUS, Diogenes. *The Lives and opinions of Eminent Philosophers*. Literally translated by C.D. Yonger, M.A. London: George Bell and Sons, 1901.

- MCCONACHIE, Bruce. *Engaging Audiences. A cognitive Approach of Spectating in the Theatre*. London: Palgrave Macmillan, 2008.
- ONIANS, John, Eric Fernie. "Neuro ways of seeing. Neuroarthistory". *Tate Etc*, issue 13, 1 May 2008. Web. July 26 2015.
- NUSSBAUM, Martha, *The Fragility of Goodness: Luck and Ethics in Greek Tragedy and Philosophy*, Cambridge: Cambridge University Press, 2001.
- PAVIS, Patrice. *Dictionary of the Theatre – Terms, Concepts and Analysis*. Toronto: University of Toronto Press Incorporated, 1998.
- PLATO, *Alcibiades I*. Project Gutenberg. Web. May 25 2015.
- PLATO, *Meno and Phaedo*. Cambridge: Cambridge University Press, 2011.
- PLATO, *The Symposium and The Phaedo*. Wheeling, Illinois: Harlan Davidson, 1980.
- RICHARDS, Mary. *Marina Abramović*. London and New York: Routledge, 2010.
- RIZZOLATTI, Giacomo, Corrado Sinigaglia. *Mirrors in the Brain – How Our Minds Share Actions and Emotions*. Oxford: Oxford University Press, 2008.
- ROSE, Martha L. *The Staff of Oedipus. Transforming disability in Ancient Greece*. Michigan: The University of Michigan Press, 2003.
- ROSENBAUM, David A. *Human Motor Control*, Waltham: Academic Press, 2010.
- SOPHOCLES. *Antigone, Oedipus the King & Electra*. Oxford: Oxford University Press, 1994.
- Fox, Jonathan M.D. (editor). *The Essential Moreno: Writings on Psychodrama, Group Method, and Spontaneity by J.L. Moreno, M.D.* New York: Springer Publishing Company, 1987.
- Wilson, Robert A and Frank C. Keil (editors). *The MIT Encyclopedia of the Cognitive Sciences*. Cambridge, Massachusetts, London: The MIT Press, 1999.
- The Republic of Plato*. Second edition, translated with notes and an interpretive essay by Allan Bloom. New York: Basic Books, 1991.
- UBERSFELD, Anne. *Reading theatre*. Toronto: University of Toronto Press, 1999.

RALUCA BLAGA read *Theatre Studies at the University of Theatre Art Tirgu-Mures and Mathematics – Informatics at Petru Maior University Tirgu-Mures between 2002-2007. Between 2006 and 2008, she was part of Theatre 74's team – an independent, alternative theatre. As a program manager, she took part in putting on productions and also touring with them in national and international festivals.*

Between November 2008 and September 2014 she was the literary secretary of Studio Theatre – University of Arts Tirgu-Mures. In 2012 she defended her doctoral thesis entitled Adaptations of Tragic in Contemporary Dramaturgy and joined the teaching-staff of the University of Arts, Tirgu-Mures

CREATION, INTERVIEWS, MISCELLANEA

Spectators or Participants? A Major Creative Shift in Performing Arts or a Change of Status? (Remarks on a Process)

MARIAN POPESCU*

Abstract: This article is a reflection of my research on the Anatomic Theatre. I question the theatre performance in the digital culture that makes out of this specific artistic procedure - to place the viewer as a Witness or as a Participant - one of the accommodating narratives of the theatre. Theatre direction is thus a μεταφορά ("transport" in Gr.), a theoretical vehicle that would result in a practice where viewers' position towards performance is disputed between being Spectator or Participant.

Key words: spectator, theatre, performance, perspective, identification, representation, consubstantiality, digital culture

Spectators have since long been considered as receivers of an event, of a thought, created, materialized and presented to them. Or of an object called work of art and crafted purposefully to split from its creator and get a status either by "navigating" at random or being fixed in a museum, a library, a cinema hall.

Being a receiver is an unrecognized status in relation with the event. People are supposed to be viewers and manifest a certain acknowledgement towards what is to be seen. But their quality as spectators comes from a constraint: they should be there to see, which is not felt as such.

See and View

Most of the theatre treaties and other theoretical, esthetical works consider spectators as *viewers*. People are aware that they would come to special places to see, to witness what is to be presented on stage. Several words describing

* Professor of Performance Studies and Communication at the University of Bucharest, e-mail: marian.popescu@fjsc.ro; <http://www.marianpopescu.arts.ro>

different activities, among which we see a theatre performance, are part of theoretical and professional language: theatre, theory, and theatrical. They all have to do with the idea of seeing, viewing. A *spectator* is someone who sees but has also a point of *view* about that experience. Very often this proves to be a mere impression. The creators of an event called “theatre production”, “theatre performance”, “performance” are always compelled to comply with space limits in the case of conventional/traditional theatre buildings. How they think theatre viewers will focus on the event is not such a long history. Spectators too have to follow certain spatial restrictions. If we talk about an in-door ticketed event, the number of viewers who buy their tickets may be aware that there are “good”, “very good” or “best” seats in a theatre. However, their number is limited. The visual experience is therefore dependant on both the seat and the *focus* you are able to exert when watching a theatre performance.

Let us remember some basic facts. One of the oldest descriptions of what theatre means is in *Nāṭyaśāstra*, one of the oldest known treatise on theatre. Gods asked Brahmā to create “a sort of entertainment to see and listen to”. Theatre is also called here as “an object of entertainment and amusement”, “something like a play”. However, the two essential characteristics stay the same for any performance: “the visual” and “the audible”. (*Nāṭyaśāstra* 25, see note 13) The critics who compared this first ever reference to theatre to Aristotle’s *Poetics* or to later theoretical writings on theatre, had to take into account the context within which they were wrote and their addressees:

So, with Aristotle, we can assume a manifest address in the *Poetics* to the potential playwright (in contrast to the actor) or poet, but the address to Plato and the continuing discourse of philosophy in the Greek schools is even more pronounced. The *Nāṭyaśāstra* codifies procedure and possibility most explicitly for the director or supervisor of a company, at times shifting its address to the playwright, but its immediate addressees, the sages who question Bharata, are part of a far more imposing fiction that is essential to the work. (Graham 191)

As both treatises concern not only the kind of discourse they were based on but also their destination, one may easily see that the visual experience is differently reflected by the two: while in the Indian treatise it is more developed, in the Aristotelian writing it is less. While oriental traditions based their visual presentation of the performance on the body and the colors (masks, body painting, colored lights etc.), the Western tradition of theatre acknowledged a strong influence of Aristotle but also of Greek and Roman creativity in Architecture and Visual Arts, especially Painting.

Therefore, one of the key-issue of the Western theatre was thought to be the *perspective*. Renaissance architecture and various schools of master-painters developed an outstanding sense of framing the visual and channel the viewers' focus on objects (from buildings to domestic objects painted on canvas or shaped in ceramics) in relation with the space. Not so rare were the techniques to create illusions, false perspectives, and absorption of the spectator into the work (a painting, for instance, or a certain inclusion of the spectator into the action on theatre stage). Psychology of vision credited since not so long that "we are remarkably good at recognizing pictures of objects as representations of the objects." It is not so surprising then that many of the researches and experiments in visual domain have been conducted with regard to pictures of objects than to the objects themselves. (Wade; Swanston 243) This has a strong effect upon spectators' ability to recognize and visually appropriate objects and parts of stage set especially when they are seated at distance or when their perspective on the visual ensemble of the stage is distorted.

One of the questions for creators or organizers of a theatre production was and still is to shape the representation according to the visual perspective of the spectator. As we know, this is not always the case especially where the theatre space or the stage imposes constraints often impossible to overcome. What is more, the need to reduce the *distance* between spectators' area and the stage has often been responded to by artificial procedures and maneuvers and not through an intimate, "natural" proceeding sprung from the director's *vision*.

Symbolic Form and Representation

In fact, when we talk about a theatre director's vision, one of the director's difficulties from the very beginning concerns the *type of representation* s/he is going to put to work. Spectators are included in it in different ways. According to the choice that has been made, the representation will make visible what Ernest Cassirer names "the presence of the content". Hubert Damisch carries on the idea (Damisch 30) to acknowledge the *directing* factor within representation as a symbolic form:

Ce n'est que par et dans cette représentation que devient possible ce que nous appelons le donné et la présence du contenu" (Cassirer 12, *apud* Damisch). Encore faut-il, pour qu'on soit en droit de parler de symbolisme, au sens le plus actuel du terme, que cette représentation, procédant comme elle le fait d'une manière de *mise en scène*, ou de scénographie naturelle, et d'une puissance de signifier antérieure à toute position d'un signe singulier, soit prise dans un réseau de

relations qui obéisse à un principe de constitution propre, lequel imprimera à son tour sa marque sur toutes ses productions. Les « formes symboliques» n'ont, en dernière analyse, pas d'autre but, ni d'autre effet, d'autre *produit* que celui-là: "*la conquête du monde comme représentation*" (Cassirer 13 *apud* Damisch)

The symbolic dimension of a theatre production is taken into account mostly when it comes to modern versions of classical texts. The presence of the content means the actual form the representation will present to audiences, which are not aware about it, but led to discover it within of process of witnessing the performance. What does Cumberbatch's Hamlet (2015) mean compared to Olivier's (1948), for instance? Does the former interpretation give justice to the director's vision and content of representation and differentiate on the same grounds from the latter's?

Spectator's Identification With...

Another key-issue that painters and theatre directors address from different perspectives, cultural and visual, is the *identification factor*. Kenneth Burke made a sound analysis of what this means and to what this lead: *consubstantiality* (Burke 21). In the case of spectators, the identification process follows specific paths in cinema or theatre and the consubstantiality is the result of "acting together" in the normal process of life, a result active when participating to a performance. In a study dedicated to film, David Blakesley proceeds from Burke's ideas to detail the process:

Identification is inherently an acting-together of subject-object, with identity a constructed middle ground in the symbolic (visual and verbal) realm where individual identity can be played out, reformed, channeled, encoded, visualized, and even asserted as if it were a verbal and visual proposition. (Blakesley 124)

This process is differentiated according to the physical place of the spectator. The function the theatre director ascribes to him/her says something important about the type of consubstantiality the director is looking for, but not too much about the kind of *participatory act* as such.

Witness and/or Participant

Boundaries between witnessing and participating are not always as clear as one may suppose them to be in the artistic practices. In fact, contemporary artistic and performance practices make these boundaries a dynamic "acting together" that would eventually get the shape of a visual representation which s/he would (not) identify with.

Theatre performance in the digital culture makes out of this specific artistic procedure - to place the viewer as a Witness or as a Participant - one of the accommodating narratives of the theatre. Theatre direction is thus a *μεταφορά* ("transport" in Gr.), a theoretical vehicle that would result in a practice. Michel de Certeau identifies these artistic practices originated from narratives as narratives of "voyage", which are, in fact, "pratiques de l'espace". De Certeau made this important discovery, highly significant for our theme here, that:

L'espace serait au lieu de ce que devient le mot quant il est parlé, c'est-à-dire quand il est saisi dans l'ambiguïté d'une effectuation, mué en un terme relevant de multiples conventions, posé comme comme l'acte d'un present (ou d'un temps), et modifié par les transformations dues à des voisinages successifs.

His concluding remark is that "space is a practiced place" (De Certeau 173) and we can think that a place for spectators, in order that they be real participants, is not identical with the seat but with *his/her practice of that space*. Actual theatre performances would either try to give spectators a new status as witness living in the digital culture, or would put them in the position to practice a place chosen for a specific artistic practice.

In fact, a major shift from the old visual habits of perspective and representing things and human body in space is taking place: towards a new paradigm of consubstantiality heavily challenged by the actual habits of IT devices, that would make spectators be, simultaneously, together, but physically separated. Theatre performance is heavily trying to respond to a much faster technological process than the artistic process of practicing spaces. However, globalization should be mentioned as some of the new artistic practices actually reinstall, on a digital culture level, the ancient Greek acting together in the amphitheatres or law courts in the cities.

References

- NĀṬYAŚĀSTRA, translated from Sanskrit and edited by Amita Bhowe, Constantin Făgețan, București: Editura Științifică, Bibliotheca Orientalis, 1997, Print
- BLAKESLEY, David. "Chapter Five: Defining Film Rhetoric: The Case of Hitchcock's *Vertigo*," in *Defining Visual Rhetorics*, ed. Charles A. Hill and Marguerite Helmers (Mahwah, NJ: Lawrence Erlbaum Associates, 2004), 124, <http://www.questia.com/read/104638134/defining-visual-rhetorics> (accessed august 2, 2015)
- BURKE, Kenneth. *A Rhetoric of Motives*, Berkely/Los Angeles/London: University of California Press, 1969 (orig.ed. 1950), Print

- CASSIRER, Ernest. *Philosophie der Symbolischen Formen*, I, Berlin: "Die Sprache", 1923
(quoted in Damisch)
- DAMISCH, Hubert. *L'origine de la perspective*, Paris: Flammarion, 1993
- De CERTEAU. Michel. *L'invention du quotidien. 1. Arts de faire*, Paris: Gallimard/Folio, 1990, Print
- LEY, Graham. "Aristotle's Poetics, Bharatamuni's Natyasastra, and Zeami's Treatises: Theory as Discourse," *Asian Theatre Journal* 17, no. 2 (2000), © 2008 University of Hawaii Press. © 2000 Gale Group. <http://www.questia.com/read/1G1-68872769/aristotle-s-poetics-bharatamuni-s-> (accessed august 2, 2015)
- WADE, Nicholas J. and SWANSTON Michael T. *Visual Perception: An Introduction*, 2nd ed. (London: Psychology Press, 2001), 243
<http://www.questia.com/read/108802985/visual-perception-an-introduction.natyasastra-and> (accessed august 1, 2015)

MARIAN POPESCU is Professor at the University of Bucharest where he's currently teaching Public Communication, Performance and Creative Communication, Journalism and the Performing Arts and Presentation and Speaking in Public. Main expertise in: Communication, Performing Arts and Cultural Policies. In 2011 he published *Theatre and Communication*. Current research activities are focused on the performativity of speaking in public.

Who is the Audience? (And what is theater?)

MIHAI PEDESTRU*

Abstract: This review attempts to synthesize the many points of view concerning contemporary American theater and audience engagement collected and curated by playwright Caridad Svich into the online salon Audience (R)Evolution. The articles, coming from theater practitioners mostly from the independent side of the spectrum, try to shed light on the debates about dwindling theater attendance, particular audience engagement strategies and the ways American theater copes with the new generations of spectators.

Keywords: Audience engagement, theatre audiences, American theatre, virtual theatre

Starting in 2012, the Theater Communications Group in partnership with the Doris Duke Charitable Foundation has developed and implemented a complex program, *Audience (R)Evolution*, aimed to study and devise audience engagement models across the United States theatrical landscape. The 150 theater practitioners participating in the program, supported by \$ 65000 grants from the Foundation, were asked to “(Re)Model or (Re)Imagine” audience engagement. The results, published since 2015 as small articles, opinion pieces, manifests and even poems were gathered into an “online salon” curated by playwright Caridad Svich and are freely available on TCG’s website. This gallery contains (as of this moment) 50 pieces, ranging from practical approaches and project descriptions to theoretical models and even radical manifestos stretching the traditional boundaries of what we are used to call theater.

We intend, in this review, to briefly summarize the vast landscape of insight provided by the initiative by means of three distinct topics: “who is the audience?”, “how do theaters engage the audience?” and, last but not least, “to what extent is (American) theater willing to change its set of fundamental axiomatic definitions in order to accommodate a changing audience?” While this last item

* Teaching Fellow at the Babeş-Bolyai University’s Faculty of Theatre and Television, Cluj-Napoca, e-mail: mihai.pedestru@mail.ubbcluj.ro

certainly does not seem to fit with the rest, it emerges as a vital one after reading the articles in question, because non-traditional and even “heretical” strategies seem to prove the most effective in engaging otherwise apathetic spectators.

Who is the (new) audience?

The most concise definition of a “new audience” comes from *Applied Mechanics*, a Philadelphia-based ensemble working in immersive theater. In the collectively-signed article “Activating Audience: Theater of Radical Inclusion”, they state their observation that: “Applied Mechanics has been developing new forms of audience engagement over the last six years and we’ve come to see a different kind of audience: people who grew up on video games and internet want art they can walk through and not just watch.”

The idea is reinforced by Tiffany Vega, General Manager of *Hi-Arts Theater Company* who, after working in community theater in East Harlem, notices that “An active and engaged audience needs to feel like a theater company is constantly thinking of them, as if a season has been curated specifically with them in mind ... We want our community to feel like they have ownership of the art and the space.”

What both Hi-Arts and Applied Mechanics seem to have in common is the rather small audience and strong community involvement. In fact, this “theater for the community” ideal occurs recurrently throughout most, if not all, articles in the series. We see the companies setting aside the mass bourgeois entertainment industry of Broadway in favor of small towns or boroughs, where the relationship between artists and spectators can be much intimer and personal. Such is the case of the Obie Awarded *PearlDamour* team’s project *Milton*, in which the artists visit five small towns named Milton across the United States, directly engaging their inhabitants, sometimes all of them, both online and offline, in order to devise a performance about small town life, to be performed in the Miltons.

The main merit of the online gallery, however, is that, by allowing contradictory points of view, it sparks a solid debate about both what audiences need and want and the role they play in the theater phenomenon as a whole, without pointing out an obvious answer. As the curator herself asks, in her article suggestively entitled “Please Please Please Let me Get What I Want (even if) You Can’t Always Get What You Want”: “Who is our audience, then? Who do we think is our audience? And is there such a thing as a monolithic body called the audience in the first place?” She goes on to bring a counterargument to the community audience initiative by quoting an anecdote:

A producer wisely remarks in one of the discussion sessions over these last few days in Kansas City that when a practitioner with whom she was working once asked a group of homeless people living in a tent village in one of our American cities about what kind of theater they most wanted to see, the answer was not one that represented their own misfortune, but rather "Dreamgirls" instead. Give me the glitter and magic and spectacle, please, and not mere verisimilitude of what my own life is like!

The audience, as seen, is certainly not a monolithic body, with unified needs and desires. Some people react positively to close, intimate experiences, others to glamour and lavish shows. There is no such thing as "one theater audience" as there is no such thing as "one theater".

There appears, however, to exist a sort of dichotomy between two echelons of spectators: the elder (and dying) audience of regulars and a young, disinterested, irregular audience, enraptured by video games and reality television, who does not care for theater and, as playwright Justin Maxwell puts it, "The new audience is out there, but it doesn't know we exist; it doesn't know that what we do is possible, and it is trained not to look."

This change of generation is at the heart of TCG's project and all audience engagement strategies are meant to prepare both theater for its new audience, and the new audience (also called "millennials" or "digital generation") for theater spectatorship. This new generation, however, is not monolithic itself, not even in its disregard for the performing arts, and here resides one shortcoming of the entire series; few articles if any, even if they differentiate between "old" and "new", proceed to further examine what this "new" is and how different its segments can be.

Melissa Hillman, Artistic Director of Impact Theatre in Berkeley, starts from the lucid observation that "The main concern about diversity in our industry isn't creating art that attracts young people and people of color – we have that already – it's creating art that keeps the upper echelon of theatremakers employed in a changing demographic environment". And then she presents an extremely poignant argument, perhaps the most interesting in the entire series, about the role money has in shaping audience research and, subsequently, our *weltanschauung* concerning these audiences. Theater "that counts" (for audience studies and surveys), she says, is the well-financed theater, with budgets exceeding 100,000 dollars, centered on elder, white spectators. As these spectators are slowly dying of natural causes, so is this instance of theater. Because scholarship focuses extensively on this form, ignoring the others, we perceive that theater, in its entirety, is dying as well.

This is not the case, says Hillman, as the independent scene is flourishing; it manages to attract and maintain young and diverse audiences by adhering to three simple principles: "Tell the stories that audience wants to hear, all the time, charge realistic prices, and create a welcoming environment". By addressing small audiences in different settings instead of a large, mixed audience in a unified setting, independent theater, it seems, has already found the solution to the falling attendance problem, rendering the whole discussion about audience engagement rather moot. To surmise the author's opinion, instead of trying to attract young spectators to the dying mainstream theater, we should let it die and focus on the one that is alive and well, even if this would mean breaking with tradition.

How does (American) theater engage the audience?

The specific actions undertaken by the artists and professionals participating in the *Audience (R)Evolution* project are varied. They do, however, fall under three main categories with one common goal - narrowing the gap between performer and spectator: *creating about the spectator, creating with the spectator* and *cultivating community*.

In the expressively titled article "Stop writing for zombies: Teaching students to create for contemporary audiences" playwright and Pennsylvania University professor Jacqueline Goldfinger challenges the foundation of artistic education in the field of theater, criticizing the art schools' over-insistence on classic authors and aesthetics. Quite radically, she states: "Let's leave the O'Neill, the Mamet, the Wilson, the Greeks, Shakespeare, even the Sheppard (whom I love more my luggage) in the literature classes, in the theater history classes, in the script analysis classes. Let's keep our playwriting workshops and contemporary theater classes current, vibrant, electric with possibility."

Her main argument is that, by relying on the same fundamental texts and models in teaching playwriting to different generations, "we are only exposing our students to ideas, aesthetics, and forms that audiences have often already absorbed and moved beyond." If the audiences cannot connect with the narratives, characters and ideas presented on stage, she contends, they will fall prey to the more comfortable mass-media.

The same ideas appear in Jody Christopherson's article "Stages of the Lower East Side and Our Audience", albeit in a more practical setting. The article describes the artist's devised performance *Because You Are Good*, which employs some means of verbatim theater (the author does not mention this) such as interviews and everyday life observations in order to stage the stories of people from the Lower East Side neighborhood of Manhattan in front of their friends

and neighbors. According to Christopherson, spectators “are really excited about this work ... These stories transcend the fourth wall. They are part of a legacy that belongs to the audience as well, much like the Lower East Side. And by bringing awareness to that it creates a rallying cry to preserve our history and carry that inspiration into the future.” The purpose of the performance is, thusly, threefold, encompassing all three categories of action mentioned above: the audience can connect with the stories, they are part of the creation process and the performance itself helps strengthen the sense of community; the same situation as in the case of Pearl Damour’s *Milton*, and many others.

The connection between spectators and narratives facilitates the connection between theater and audiences, connection which is, in its turn, reinforced by allowing the latter to participate in the creation of the performance itself. This series of reconnections allow independent theater to exploit the visceral experience of the encounter, which theater alone can offer. As Maxwell says, again about the new audience, “These students born and raised in the digital age (and educated in the contemporary American idiom) believe theatre to be the most sterile productions of Shakespeare, and maybe a little Ibsen, or some long-dead ‘Greek dude.’ They don’t know the unique things our artistic genre is capable of; they don’t know why it isn’t film and tv.” Independent theater, it would seem, managed to seamlessly “educate” its spectators about what it can offer. We will not present here all strategies employed by the artists, as these are freely available and certainly worth a more in-depth reading.

What is (no longer) theater?

Unavoidably, new audience engagement strategies reach into a gray area of “theater heresies” such as virtual theater, mediated theater and hyperdrama. We will attempt to briefly discuss some of the more interesting such initiatives described by the artists involved in the project, without wanting to spark an argument about what is or is not theater. We find them important, however, if not as performances per se, than as efficient means of appealing to the “new audience”.

Director Erin B. Mee, involved mostly in site-specific theater, presents his performance *Ferry Play*, a smartphone play, which is “an emerging genre of theatre that take advantage of mobile technology to create site-specific audio-based theatrical experiences”. While riding the Staten Island Ferry in New York, the spectator/participant can download a smartphone application containing the play, whose action happens on the ferry, in audio format. The entire environment becomes a stage, reimagining familiar items and places and immersing the audience (ranging from five to eighty year olds) in an interactive and ever-changing experience.

Middlesex County College theater professor Anna Sycamore DeMers presents her otherwise disinterested students' reaction to a site-specific performance based on Shakespeare's *Macbeth*, *SleepNoMore*. The event consists of the audience (masked and silent) freely exploring and interacting with a five story building where actors perform, in different spaces, different scenes. DeMers notes that "The mystery appealed to the students, their ability to choose where they went and which story/character they followed. They were also intrigued by the extreme physicality of the performers and that even though they did not speak very often, a story was communicated to them." She concludes that "The students not only had an experience as a spectator but they also had an experience as an actor. Without a doubt, these students were greatly impacted by this immersive performance and will likely seek more experiences like *Sleep No More*."

Playwright Steve Moore presents "an absurd experiment with technology" which managed to double attendance to his company's live performances. The narrative of their play "Computer Simulation of the Ocean" was delivered to the audience in real time, over the span of six months, solely through text messages from the three characters, received on the spectators' cellphones.

While all these approaches might seem to purists as divergent from what theater is or should be, they seem to work very well to encourage proximity with an audience for whom proximity is most always mediated.

To sum it all up, Caridad Svich's Online Salon showcases a theater that is alive, healthy, and which, searching for ways to engage its audiences, had managed to do that in a seamless and natural way. The "secret" resides not in teaching people to like theater, but in letting theater evolve together with its audiences and the world, as it, as a matter of fact, always had.

The only drawback to the gallery of texts is its lack of organization, the lack of a guiding line to help the reader navigate this impassioned corpus of manifestos, experiences and scholarly approaches. It remains, nonetheless, in my opinion, a mandatory reading for anyone interested in theatre, in general, and especially for those decrying its demise. It contains both careful reflections and practical experiments and experiences, proving a true "survival handbook", a model of action for the ailing Romanian theatre system.

References

- Applied Mechanics. "Activating Audience: Theater of Radical Inclusion". *Audience (R)Evolution Online Salon*. www.tcgcircle.org, n.d. Web. 10 September 2015.
- CHRISTOPHERSON, Jody. "Stages of the Lower East Side and Our Audience". *Audience (R)Evolution Online Salon*. www.tcgcircle.org, n.d. Web. 10 September 2015.
- D'AMOUR, Lisa, Katie Perl, Ashley Sparks. "MILTON: A performance and community engagement experiment". *Audience (R)Evolution Online Salon*. www.tcgcircle.org, n.d. Web. 10 September 2015.
- DEMERS, Anna Sycamore. "Engaging students in immersive theatre". *Audience (R)Evolution Online Salon*. www.tcgcircle.org, n.d. Web. 10 September 2015.
- GOLDFINGER, Jacqueline. "Stop writing for zombies: Teaching students to create for contemporary audiences". *Audience (R)Evolution Online Salon*. www.tcgcircle.org, n.d. Web. 10 September 2015.
- HILLMAN, Melissa. "The Lies We Tell About Audience Engagement". *Audience (R)Evolution Online Salon*. www.tcgcircle.org, n.d. Web. 10 September 2015.
- MAXWELL, Justin. "Making Eye-Contact with Millennials: the ephemeral and the visceral". *Audience (R)Evolution Online Salon*. www.tcgcircle.org, n.d. Web. 10 September 2015.
- MEE, Erin B. "Diverse Audiences for Smartphone Plays". *Audience (R)Evolution Online Salon*, www.tcgcircle.org, n.d. Web. 10 September 2015.
- MOORE, Steve. "New Opportunities for Surprise". *Audience (R)Evolution Online Salon*. www.tcgcircle.org, n.d. Web. 10 September 2015.
- RUBY, Jay. "The Volt of Resistance". *Audience (R)Evolution Online Salon*. www.tcgcircle.org, n.d. Web. 10 September 2015.
- SVICH, Caridad. "Please Please Please Let me Get What I Want (even if) You Can't Always Get What You Want (or how the Smiths and the Rolling Stones can teach us a thing or two about theatre)". *Audience (R)Evolution Online Salon*. www.tcgcircle.org, n.d. Web. 10 September 2015.
- VEGA, Tiffany. "Hi-ARTS and audience sustainability". *Audience (R)Evolution Online Salon*. www.tcgcircle.org, n.d. Web. 10 September 2015.

MIHAI PEDESTRU is a Teaching Fellow at the Babeş-Bolyai University's Faculty of Theatre and Television. Holding a PHD in theatre studies, his main research interests focus on the way the digitalization process has influenced theatrical spectatorship.

Alternative Theatre in Poland and the Communist Dystopia

ANDA CADARIU*

Abstract: Theatre as a means of social debate and commentary has always reacted to the political context of its time. One of the exemplary artistic movements of the kind is the Polish alternative theatre during communism. In communist Poland there were several groups, companies and alternative theatres that were more focused on the contents of their performances and on ethical values, rather than on aesthetic and artistic values. This means that the concern for theatre aesthetics was shifted towards theatre as a vehicle for ethical questions and problems, as well as one for social and moral change. The groups that were known for their political performances were, among others: Ósmego Dnia, Provisorium, Teatr STU, Teatr 77, Teatr Kalambur and Pstrąg. From Studencki Teatr Satyryków to Pomarańczowa Alternatywa, political theatre groups had always dealt with the ethical aspects of Poland's social reality. My paper aims to present the way the communist dystopia influenced and was reflected in the performances of some of the alternative theatre groups that came into existence in communist Poland between 1954 (the year when alternative theatre was born in the Polish community) and 1989 (the year that marks the fall of communism in Poland).

Keywords: alternative theatre, communism, dystopia, ethics, Poland, social change

The artist who engages in political activities by defending the higher ethical values in social and national life or in international relations remains consistent with his mission and implements the morality of the artist upheld by age-old tradition.
(Zygmunt Hübner, *Theater and Politics*)

Utopia, Thomas More's 1516 world-famous book, brought to the attention of its readers the image of a perfect country, of an ideal community, of a harmonious, non-entropic society. Four centuries later, the communist ideology, based on Marxism, was apparently trying to create that kind of changed world. The result, as we well know it today, was catastrophic: a real-life dystopia.

* Lecturer at the University of Arts, Tîrgu-Mureş, e-mail: anda.cadariu@yahoo.com

Theatre as a means of social debate and commentary has always reacted to the political context of its time. One of the exemplary artistic movements of the kind is the Polish alternative theatre during communism, a phenomenon I have analyzed thoroughly in my PhD thesis, entitled *Poetic versus Political. Alternative Theatre in Poland (1954-1989)*. I owe a debt of gratitude to the American academic Kathleen M. Cioffi, whose work was a very important starting point in my research. In my thesis, I have identified two tendencies in the Polish alternative theatre movement: a poetic one, in which aestheticism was prominent, and a political one, concerned mainly with the ethical aspects of everyday life. The first strand of Polish alternative theatre consists of “poetic” groups such as Gardzienice, Scena Plastyczna, Pleonazmus et al., and two great directors (Kantor and Grotowski; I consider Szajna a special case). The second tendency – the “political” one - features groups such as Studencki Teatr Satyryków, Teatr 77, Teatr Ósmego Dnia, Teatr Provisorium, and even Pomarańczowa Alternatywa, a group preoccupied with what can be called „surrealist happening”.

According to Zygmunt Hübner, this second type of theatre, the one created by the political alternative groups, falls into the category of “agitational theatre” [Hübner 1992, 139]; briefly, a theatre made by and for the young Polish intelligentsia who were not willing to give in to the communist lies. My paper aims to present the way the communist dystopia influenced and was reflected in the performances of several alternative theatre groups that came into existence in communist Poland between 1954 (the year when alternative theatre was born in the Polish community) and 1989 (the year that marks the fall of communism in Poland). The methodology used in my paper implies a diachronic perspective based on historical studies and on works of theatre history, as well as on several literary and philosophical sources that aim to outline the nature of dystopia, a key-concept of this study.

1. Communism as a Dystopian Reality

When I think of communism, the first thing that comes into my mind is the difference between ideology and the way one applies it to real life. Communism is based on a utopian ideology, while the reality this ideology tried to create in 20th-century Europe became a dystopian one. In other words, theoretically speaking, communism is utopia. Practically, it has dystopian traits. Utopia, which means an imagined place or state of things where everything is perfect, becomes its very opposite in the case of communism: that is, a dystopia, meaning a place or state where everything is unpleasant or bad, typically a totalitarian state.

Both utopia and dystopia are extreme concepts, similar to those of Heaven and Hell in the Judeo-Christian tradition. Examples of dystopian creations can be found mostly in literature. Thus, George Orwell's *Nineteen Eighty-Four* and Aldous Huxley's *Brave New World* are some of the best-known literary dystopias. Among contemporary dystopias, the most famous one is *The Hunger Games* by Suzanne Collins.

Dystopia is "a utopia gone wrong" [Gordin, Tilley, Prakash 2010, 1] and many a political utopia often goes wrong because political utopias are states of mind which are incongruous with the state of reality within which they occur [Mannheim 1936, 73].

In most of the literary works I have mentioned above, the nature of dystopia is a totalitarian one. And in real-life totalitarian states, there is a strong connection between politics and art. The state apparatus has always tried to control the artists' views (see, for example, Jdanovism in literature). Theatre is well-acquainted to these harassments. In Romania, for instance, mainstream theatre – which was almost the only form of theatre during communism – tried to escape censorship by alluding to the everyday problems people were facing. Loud opposition was out of the question. Poland's case is more or less similar when one speaks of mainstream theatre. Although the institutional model of the Polish theatre had been the Soviet one, during the "Polish October", Social Realism was given up and the censors allowed theatres to produce plays that had been banned. Political messages appeared in productions of completely non-political plays. But no matter how obvious these half-words were, they were only hints. The '50s mainstream theatre never talked about political issues, although allusions were used heavily [Cioffi 1999, 20-22]. So, during communism, just like in Romania, the artists and intellectuals who did not want to leave their country were faced with a *tertium non datur* situation: they either had to make a pact with the regime, entering thus a „velvet prison“¹, or they had to fight the oppressing powers by all means. According to the sociologist Jeffrey C. Goldfarb, as a consequence of the 1968 student protests in Poland, the authorities started to intervene decisively in mainstream theatre [Goldfarb 1980, 34]. After Gomułka's fall and Gierek's coming to power, the Party's control became more subtle: the artists were offered awards, medals and contributions in kind [Braun 1996, 66-67]. The '70s were less prolific than the '60s in mainstream theatre, but Poland became a center of visual theatre *per se* [Braun 1996, 71]. In 1981,

¹ The expression "velvet prison" belongs to Miklos Haraszti, a Hungarian politician, and it refers to the situation of those members of the intelligentsia who would sign a pact with the regime and, as a consequence, were spoiled by it. [apud Cioffi 1999, 17].

after Martial Law was declared, the Polish actors started a boycott on the media, refusing to appear in any radio or tv show [Cioffi 1999, 147]. In the '70s and the '80s, Poland witnessed the birth of the generation the most prominent member of which was Krystian Lupa. The Polish mainstream theatre was starting to show its experimental side more fully, and, after the fall of communism in 1989, it started to regain its audiences, which, having been disappointed by the mainstream, had mostly turned to the alternative theatre.

The ethical (political) branch of the Polish alternative theatre reflected more deeply than the mainstream the dissent of the artists and of the young intelligentsia. In order to understand their problems and concerns, I would like to briefly discuss the political environment of communist Poland:

2. The Social and Political Context in Poland during Communism

Although the Polish were one of the most liberal nations in the communist block, their freedom was also restricted. The adverse conditions in mid-20th-century Poland were of a political nature: at the beginning of the '50s, the communists had completely taken over the country. This suffocation of Poland's freedom would relax though, what with the denunciation of Stalinism by Nikita Khrushchev and the growing opposition in the country. October 1956 remained in history under the name of "Polish October", marking the beginning of the political thaw and Władysław Gomułka's coming to power. He did not keep the reformist promises he had made; therefore, at the beginning of the '60s, communism was flourishing again in Poland.

The next period in the country's history is known as Gomułka's "Little Stabilization". The idea that theatre was strongly connected to the everyday life of the Polish individual is enhanced by the fact that the expression "Little Stabilization" comes from the title of a play: *Świadkowie albo nasza mała stabilizacja* (*The Witnesses or Our Little Stabilization*), written by Tadeusz Różewicz. This period, which lasted up to 1970, was characterized by unsuccessful politics and a dull daily life. The only colorful events – baleful ones for that matter – were the 1968 student protests, which came up as a consequence of the authorities' ban of a performance based on *Dziady* (*Forefathers' Eve*), a play written by Adam Mickiewicz and staged at the Warsaw National Theatre by Kazimierz Dejmek. The anti-Russian scenes were thoroughly applauded, and this was followed by street protests.

In 1970, the government raised the prices of the basic products, which led to new uprisings and also to Gomułka's fall. His successor was Edward Gierek, who doubled the prices in 1976, repeating his predecessor's mistake. Strikes burst

out and the oppositional activities increased. Thus *Komitet Obrony Robotników* (KOR) was born. It was an organization the purpose of which was to help those workers who were oppressed by the authorities.

In 1978, Karol Wojtyła was elected Pope. His visit to his native land coalesced the Polish society even more, becoming thus a starting point for the change that was yet to come.

On July 1st 1980, the government raised the prices again. Strikes started anew, especially on naval yards. In Gdańsk, Lech Wałęsa became the leader of the strike and thus *Solidarność* (*Solidarity*), the first free legal trade union in communist Europe, was created. *Solidarność* became legal in September 1980.

The next leader after Gierek was Stanisław Kania, and in February 1981, General Wojciech Jaruzelski became Prime Minister. Due to the increasing conflicts between the people and the government, and to an apparently imminent Soviet military intervention, Jaruzelski declared martial law on December 13th, 1981 [Wandycz 1998, 265]. *Solidarity* again became illegal, operating underground, but before 1984, the arrested members of the trade union were freed and martial law was lifted.

In 1989, Tadeusz Mazowiecki, a close friend of Wałęsa's, had become Prime Minister, and the issue was not how to reform communism, but how to make the transition to capitalism smoother.

Thus, in 1989, like many other Central and Eastern European countries, Poland was on its way to become free from communism; the road was paved with the people's discontent with those in power and it was built by the solidarity among workers, the intelligentsia and the Church.

3. Political, Ethical, Social Theatres - From *Studencki Teatr Satyryków* (STS) to *Pomarańczowa Alternatywa*

In communist Poland there were several groups, companies and alternative theatres that were more focused on the contents of their performances and on ethical values, rather than on aesthetic and artistic values. This meant that the concern for theatre aesthetics had shifted towards theatre as a vehicle for ethical questions and problems, as well as for social and moral change.

The Polish alternative theatre groups which were formed during communism were mostly student theatres and they placed themselves in opposition to the government. This is the strand which made Polish alternative theatre famous worldwide at the time. Not many had heard of *Scena Plastyczna*, a "poetic" theatre, but the entire Western world had learnt that *Ósmego Dnia*, a „political" company, was one of the top Polish theatre groups. These „political" groups fought the authorities through their art. Not all of them survived. For

instance, Ósmego Dnia was disbanded (only to reform later, after the fall of communism) because some of its members had left their country; artists belonging to other groups, such as Provisorium, were harassed or sent to prison.

It was not easy to make political theatre in communist Poland. Some artists resorted to apartment theatre, which was oppositional in nature. The performances were held in secret and there was no applause, for fear that the authorities would intervene. Nevertheless, there were also alternative groups that were known more widely throughout the country – and not only -, for their political performances. They were, among others: Ósmego Dnia, Provisorium, Teatr STU, Teatr 77, Teatr Kalambur and Pstrąg. From Studencki Teatr Satyryków to Pomarańczowa Alternatywa, political theatre groups were dealing with the ethical aspects of Poland's social reality.

3.1. *Studencki Teatr Satyryków (STS)*

Between 1954 and 1957, the most influential alternative theatre in Poland was Studencki Teatr Satyryków, or the Satirical Student Theatre. The group was formed by students from the Warsaw University who were writing mock-satires which were addressing life in the universities [Cioffi 1996, 25].

STS was, from the very beginning, a political theatre. Instead of resorting to metaphors and other poetic means of expression, the members of STS were portraying reality in a very straightforward manner. No wonder that one of their performances was called *Idź na spacer alegorio! (Take a Hike, Allegory!)* [Cioffi 1996, 25]. The company was influenced by Mayakovsky, Gałczyński, Piscator, Brecht and Meyerhold [Tyszka 2010, 165]. STS created a theatre that was political *par excellence*; it was an intellectual kind of theatre, engaged not only in entertainment. The company dealt with other issues beside student matters; they were interested in the problems of their day [J. K. 1964, 26].

The first three productions by STS were *To idzie młodość (There Goes Youth)*, *Prostaczkowie (The Simpletons)* and *Konfrontacja (Confrontation)*, which were all moral attacks on the opportunism in the communist system. *Myślenie ma kolosalną przyszłość (Thinking Has a Colossal Future)*, their next show, parodied the mass recitations that took place during Stalinism [Cioffi 1996, 28-29].

STS dealt with the communist dystopia by means of irony and parody. Another theatre, Kalambur, took to poetry:

3.2. *Teatr Kalambur and the performance W Rytmie Słońca – Poetry and Politics*

Teatr Kalambur was founded in 1958, and it became one of the best-known poetry theatres of the 1960s. The 1968 student protests influenced the members of this company to the extent that Bogusław Litwiniec, the founder and manager of the group, felt that his theatre should react to what had happened. Therefore, he selected for a stage adaptation the poem called *In the Rhythm of the Sun*, written in 1968 by Urszula Kozioł, from Wrocław [Cioffi 1996, 108].

In this performance, the artists of Kalambur were „seeking a renewal of idealism. Theater Kalambur told its audience to dream: ‘look for a while at the sun, consider the spring of life...’. They implored their audience to nurture that dream and not be consumed by the vulgarities of the past, nor the conformism of the present” [Goldfarb 1980, 35].

So, in the beginning of the 1970s, Teatr Kalambur became concerned with the communist dystopia, as a consequence of the 1968 events. Litwiniec chose to create this aesthetically valuable but also socially-oriented type of theatre, which he called “open theatre”. *W Rytmie Słońca* remains the most important performance of this group. It propelled Teatr Kalambur to the top five alternative theatres in Poland.

3.3. *Teatr STU – From the allegorical to the universal*

In 1966, Krzysztof Jasiński founded in Cracow, the capital of the Polish arts, an alternative theatre company called STU. It was the time of counterculture and brave theatrical experiments, so Jasiński, together with future professionals from Państwowa Wyższa Szkoła Teatralna – PWST, the Theatre University in Cracow - , created this group because they were dissatisfied with what they were taught in school [Cioffi 1996, 111]. One of their best shows was called *The Falling*.

Together with *In the Rhythm of the Sun*, *The Falling (Spadanie)* (...) premiered nationally at the 1970 Student Theatre Festival at Lodz (sic!). In this play the members of STU explored the meaning of Tadeusz Rozewicz’s (sic!) poem ‘The Falling’, and specifically his words, ‘before, we fell vertically, now we fall horizontally’. STU expressed a mood of uncertainty and disquietude, that somehow something was fundamentally wrong with the social order” [Goldfarb 1980, 35].

Spadanie was composed of several scenes „presenting anomalies of socio-political thought and rethoric” [Goldfarb 1980: 35]. The first part of the production was a critique of literary models, while the second part was raising the issue of the part young people were playing in a socialist society. After Gomułka’s fall, Teatr STU improved the performance so as to reflect the change

in the nation's political consciousness. Thus, the second version ended with the question: 'How do we go on and with what?' [Cioffi 1996: 113]. Kathleen Cioffi thinks that the political message of *Spadanie* was combined with a moral one and that this moral exploration was the most valuable contribution that this performance made to student theatre, because it framed political questions as ethical ones [Cioffi 1996, 114-115].

In their following productions, *Sennik Polski (Polish Dreambook)* and *Exodus*, the artists of Teatr STU transcended the allegorical approach to politics and tried to deal with universal problems. While STU was trying to maintain a balance between the ethical and the aesthetic, there was another theatre the members of which were consciously experimenting with ethical problems. The name of that theatre was Teatr 77:

3.4. Teatr 77 – *Playing with the audience*

Zdzisław Hejduk, the manager of Teatr 77, told Jeffrey C. Goldfarb:

For us, the most important thing is not to realize a successful play, we try rather to bring to society some of our political ideas with the help of the theatrical form. We try to activate action beyond the theater...[Goldfarb 1980, 133].

Hejduk's words are an accurate description of the type of theatre created by the members of 77 – it was a political theatre, aiming beyond the borders of art. In *Koło czy tryptyk (Circle or Tryptych)*, their first important production, the artists of 77 raised a question: Will Poland fall again into old patterns? Will it return to the old intolerable habits, or will this be the last new beginning? Will Poland avoid the problems it had previously faced? [Goldfarb 1980, 97]. During the performance, the audience and the actors are listening to recorded voices of ministers who made speeches in times of political crisis. Then the actors start asking questions, and sometimes, members of the audience join them [Cioffi 1996, 128-129].

In their next productions, *Passion II* and *Retrospective*, the artists of Teatr 77 also deal with aspects of the communist dystopia. For example, in *Passion II* there is a scene of a revolution, while in *Retrospective*, the performers act out important events in the history of Poland. Jeffrey C. Goldfarb writes:

Polish people, who are acquainted with the work of 77 speak of the theatre group only with admiration. People in and out of theater, people from all over the country, speak of the quality of their work and of their bravery" [Goldfarb 1980, 133].

But by the end of the 1970s, the authorities had started to restrict the work of this theatre, so that the group could not produce performances as powerful as those at the beginning of the decade. [Cioffi 1996, 134]. Teatr 77 aimed to create

productions that were more performative than contemplative, playing thus not only *for* their audience, but also *with* their audience. All the performances I have mentioned here could be characterized, „in Richard Schechner’s parlance, as works of ‘environmental theatre’” [Cioffi 1996, 128].

3.5. *Teatr Ósmego Dnia as a leader of Polish counterculture*²

Ósmego Dnia or the Theatre of the Eighth Day is a world-famous Polish alternative theatre company. The artists were influenced mainly by Jerzy Grotowski [Kornaś 2007, 54], but the group created their own style based on improvisation. The company was founded in 1964, in Poznań, as a student theatre. In the 1970s, their views and their inability to compromise with the political regime brought them to the attention of the authorities. Even so, they managed to produce some of the most valuable performances of the decade. Among them we can count *Jednym Tchem (In One Breath)*, 1971, or *Musimmy poprzestać na tym, co tu nazwano rajem na ziemi...? (Do We Have to Settle for What Has Been Called Paradise on Earth?)*, 1975.

In 1970, the group premiered *An Introduction To...*, a performance which was „a parody of the celebrations commemorating Lenin’s birthday” [Cioffi 1996, 122]. In the 1971 performance with *In One Breath*, The Eighth Day presented a commentary of the 1968 events. The production was based on poetry by Stanisław Barańczak, and it was a success. Tadeusz Nyczek wrote, in 1971:

In One Breath [...] clarified the lies we, the contemporary Poles, tell about ourselves, while we are living among deeply entrenched falsehoods, among illusionary truths and hidden lies (...) [Nyczek 1971/2009, 209].

The ideal of the Polish group was freedom, and this is what they expressed in their art. Grzegorz Kostrzewa-Zorbas was writing, in 1982, that The Eighth Day was a part of the Polish countercultural movement [Kostrzewa-Zorbas 1982: 13] and I would like to underline the fact that they became the leaders of this movement, at least in the theatrical field. According to Professor Tadeusz Kornaś, in the seventies, the artists of Ósmego Dnia „experienced problems in their everyday lives: police searches, arrests without cause, prohibited performances and provocations” [Kornaś 2007, 55].

Between 1976 and 1979, there was a media blackout on The Eights. But they continued to produce quality performances all this time. One in particular drew my attention when thinking of the communist dystopia. It’s called *Przecena dla wszystkich (Discounts for Everybody)*, and it premiered in 1977. In this production,

² For an extended case study of this group, see my paper *Teatr Ósmego Dnia – a Vision of Freedom – in Symbolon*, issue 1/2012 (year XIII, no. 22).

the artists of the Eighth Day resorted to irony, and they tried to show the effects that a corrupted political life had on the common man. The artists were using irony in a fashion that permitted them to say things like margarine is better than butter and brass shines more than gold [Cioffi 1996, 158].

The Theatre of the Eighth Day artists were friends with members of the *Solidarity*; they were harassed by the authorities and produced many of their performances in churches; they separated due to the oppression of the government. Some of them immigrated and then returned when they were invited back home after the fall of communism. I had the honour of interviewing Ewa Wójciak, now the manager of the theatre, and she told me that in their minds, the artists of *Ósmego Dnia* did not respect any censorship. That is probably how they survived.

3. 6. *Text, image and dissent: Teatr Provisorium*

Teatr Provisorium was created by Janusz Opriński in Lublin, in 1976. The members of this theatre were more philological in nature, they were friends with the artists from *Ósmego Dnia*, and they were fighting against the politicization of art, typical for communism. The first notable production by Provisorium was *Nasza Niedziela (Our Sunday)*, which, according to Kathleen Cioffi, „attempted to portray the ethical and practical dilemmas resulting from what it felt was the abnormality of Polish life under the Communists” [Cioffi 1996, 168]. The performance was censored because it was based on the writings of Czesław Miłosz and Provisorium became thus an „oppositional theatre” [Cioffi 1996, 168]. Another one of their productions was banned for reasons of national security [Kornaś 2007, 69] and eventually several Provisorium artists went to prison.

This group is compared to *Ósmego Dnia* because of their heavily-oppositional stance towards the communist regime.

3. 7. *Pomarańczowa Alternatywa and the surrealist happening*

Last but not least, I would like to tackle the subject of Pomarańczowa Alternatywa or The Orange Alternative. They created happenings, painted graffiti and were led by Waldemar Frydrych, nicknamed „The Major”. Frydrych published a manifesto which postulated that what was happening in communist Poland was no less than „social surrealism”. The happenings of the Orange Alternative took place at first on the occasion of every national holiday and then they were organized even more often. They parodied communism, and not only. Some of their „victims” were *Solidarity*, the Church and even The United States.

For Pomarańczowa Alternatywa, the colour orange became an alternative to red, which evoked the authoritarian symbols of the time [Nizyńska 2011, 68]. Once, they created a happening in which everyone was supposed to wear something red as a parody of the authoritarian regime in Poland. Over 150 people were arrested, some of them unaware passers-by dressed in red [Cioffi 1996, 177].

Through their happenings, the members of Pomarańczowa Alternatywa succeeded in creating a culture of protest the main purpose of which was, just like that of other politically-engaged theatres, the fight for freedom.

Conclusions

In this paper, I have tried to shift the focus from theatre as a vehicle of aesthetic achievements and place it on theatre as a means of social change and socio-political reflection. I have chosen to do this by briefly analyzing the oppositional strand of Polish alternative theatre during communism. I have stated above that communism is a utopia gone wrong, i. e. – a dystopia. The Polish alternative theatre groups, from STS to Pomarańczowa Alternatywa, were all politically engaged and less concerned with aestheticism, unlike those (Gardzienice, Scena Plastyczna, Bim-Bom et al.), belonging to what I consider the other strand of Polish alternative theatre: the poetic one. Some of the alternative groups in Poland, Ósmego Dnia for instance, balanced aesthetic experiments with ethical messages, while others, like Teatr 77, were concerned with social change and not with aesthetically pleasing the audience. STS used irony and parody to mock the communists, Kalambur started its endeavours to change the social environment by resorting to poetry, while STU was trying to play with the subtleties of meaning (from the allegory to the anagogy). Such was the landscape of the political alternative theatres in Poland, and the forms of dystopia-reconstruction on stage were varied in this landscape, since each remarkable group had its own remarkable artistic voice. If one were to compare their work, one would find similarities between the artists' attitudes toward the oppression that kindled the revolutionary spirit of their performances. Another similarity would be the fact that most of them started as student groups but became professional companies in the '70s. All of them were concerned with socio-political matters; however, each company tackled these matters in its own way, using its unique voice.

The Polish alternative theatre movement is a top example of what the aesthetic and the ethical can do for a society when their powers are combined. Alternative theatre was a means of reflecting social dissent in Poland and it contributed to the major political changes of 1989, a year that marked the end of a dystopia for many Central and Eastern European countries.

References

- BRAUN, Kazimierz, *A History of Polish Theater, 1939-1989: Spheres of Captivity and Freedom*, Greenwood Press, Westport, 1996;
- CIOFFI, Kathleen M., *Alternative Theatre in Poland (1954-1989)*, Harwood Academic Publishers, s.l., 1996;
- GOLDFARB, Jeffrey C., *The Persistence of Freedom: The Sociological Implications of Polish Student Theater*, A Westview Replica Edition, Westview Press, Boulder, Colorado, 1980;
- GORDIN, Michael D.; Tilley, Helen; Prakash, Gyan, *Utopia/Dystopia: Conditions of Historical Possibility*, Princeton University Press, Princeton, NJ, 2010 (Questia);
- HÜBNER, Zygmunt, *Theater and Politics*, Northwestern University Press, Chicago, 1992;
- KORNAŚ, Tadeusz, *Between Anthropology and Politics – Two Strands of Polish Alternative Theatre*, translated into English by Caryl Swift, revised and edited by Virginia Preston, editor Katarzyna Szustow, published by Instytut Teatralny im. Zbigniewa Raszewskiego, Warsaw, 2007;
- KOSTRZEWA-ZORBAS, Grzegorz, *Teatr Ósmego Dnia – 1981 „More than One Life“*. A collective creation under the direction of Lech Raczak with the company's proper texts and a poem „Waltz“ by Czesław Miłosz. Music by Lech Jankowski, in *Le Théâtre en Pologne/Theatre in Poland*, issue 1/1982, Warsaw;
- K., J. *A Jubilee of the Studencki Teatr Satyryków*, in *Le Théâtre en Pologne/Theatre in Poland*, issue 1/1964, Warsaw;
- MANNHEIM, Karl, *Ideology and Utopia: An Introduction to the Sociology of Knowledge*, Routledge & Kegan Paul, London, 1936 (Questia);
- NIŻYŃSKA, Alexandra, *Street art jako alternatywa forma debaty publicznej w przestrzeni miejskiej (Street Art as an Alternative Form of Public Debate in the Urban Space – consulted in Polish)*, Trio Warszawa, 2011;
- NYCZEK, Tadeusz, s. t., in *Student*, nr. 12/1971, apud ***, *Teatr Ósmego Dnia*, Ośrodek KARTA, Dom Spotkań z Historią, AGORA SA, Varşovia, 2009, p. 209;
- TYSZKA, Juliusz, *Student Theatre in Poland: Vehicles of Revolt, 1954–57 and 1968–71*, in *New Theatre Quarterly* (2010), vol. 26, nr. 2, Cambridge University Press 2010;
- WANDYCZ, Piotr S., *Prețul libertății – O istorie a Europei central-răsăritene din Evul Mediu până în prezent (The Price of Freedom – A History of Central-Eastern Europe from the Middle Ages to the Present – consulted in Romanian)*, translated into Romanian by PARASCHIVESCU Mihaela and DRAGU-BANU Valentin, ALL Publishing House, 1998.

ANDA CADARIU is a lecturer at the University of Arts, Tîrgu-Mureş. She graduated from the Faculty of Letters, Babeş-Bolyai University, Cluj-Napoca (2003). Her B. A. was followed by an M.A. in Cultural Anthropology at the University of Bucharest (2004) and by a PhD in Theatre Studies at the University of Arts, Tîrgu-Mureş (2013). She worked for CONCEPT Foundation and the Polish Institute in Bucharest, and won a postgraduate scholarship offered by the Queen Jadwiga Fund of the Jagiellonian University in Cracow. A part of her PhD research was undertaken in Poland due to an Erasmus placement at the Institute of Polish Culture within the University of Warsaw. She has published essays, reviews, fiction and interviews in the following magazines and journals: Echinox, Vatra, Bucureştiul Cultural (cultural supplement of 22 magazine), Observator Cultural, LiterNet, Cultura, Symbolon et al.

The Casting or the Two-Headed Spectator – a give and take process¹ –

DIANA ALDEA*

Abstract: This paper analyses the process of casting in theatre, by focusing on the actor-director information exchanges. The author starts from the premise that a casting session is, essentially, a *theatrical situation* with two players who alternate their roles.

Keywords: casting, director, actor, limit encounter, emotion, non-verbal language, blocking, attention, observation, neurosciences

To observe a casting session is a privilege. Perhaps many people would like to get in a casting room, drawn by the opportunity to surprise the actors at their most “vulnerable”, while wavering between the “civil” being and the character, committed to the complex relationship with the director and with the latter’s indications. The turbid or glowing waters in which the actors swim, the moment of inspiration, the hazard or, on the contrary and at the same time, the anxiety, the stumbled lines, the altered voice, the failure, the indecision relate to the backstage area that has always been provoking for the spectator. The tests to which the actors are submitted during casting are reminiscent of the rehearsals, because the making of the cast is also a search, a *work-in-progress*, a process with an unpredictable ending, able to draw like a magnet.

As an outsider, one might believe that, in an audition, the director plays the part of a cold, calculated individual, whose intentions are impenetrable, and who is present only to pick the few most “gifted” from the many.

¹ The phrase *give and take*, borrowed from the terminology of the work with the actor, seen at Viola Spolin and at other practitioners, defines the way and the essential rule according to which an improvisation occurs: when a partner takes the initiative (*take*), the other one will temporarily “hand over” (*give*) the lead of the game. The partners take and give the initiative alternatively and spontaneously.

* PhD candidate at Babes-Bolyai University, Theatre and Television Faculty, email: dianaaldea9@yahoo.com.

However, since I have had several times the opportunity to observe closely the casting process, I believe the audition means instead, as put by George Banu, a **mutual** “close” supervision (Banu, 2007, 153) between the actor and the director; in a relatively short time, a series of focus shifts occurs, each of them being both the observed and the observer, both the spectator and the performer. In a limited time, the two exchange information intensely, verbally and non-verbally, so that the Other evolves from an anonymous individual in a partner, defined as an artist and a human being.

In fact, the *casting relationship* is the *meeting* of two people, of whom the director usually keeps a low profile. Although the director’s status and role mean a static, physically passive presence, he/she is fully involved. Of course, the director has an apparent superiority, a position which, however, does not influence the balance of the relationship with the actor. On the contrary, it is natural as long as the director’s objective is to pick, in the meeting with the actor, the maximum amount of specific information and then to select and interpret it. The actor – the director’s relational double, “in the limelight” (unlike the latter), hence, the only one who is “visible” – is required to apply full (physical and psychological) immersion in the brief span of their meeting; because, unlike the rehearsals, the casting room conditions are not protecting the actor, whereas the director’s sympathy reflects his/her interest in erecting a construction in optimal conditions. In casting, the time limit, the goal of the meeting, and fatigue are experienced differently.

Thus, we may consider a *limit-encounter*. For a researcher, it can be an extraordinary opportunity to study the complex exchange of verbal and especially non-verbal messages, the existing types of emotions, in other words, considerable information approachable with the tools of the neurosciences, of psychology or of anthropology.

As found by modern bio-psycho-physiology research, how we live and how we show ourselves forth are aspects defined by the “chemical processes in our body, by the biological interaction among organs, by the tiny electrical currents jumping between the synapses of the brain, and by the organization of information that culture imposes on our mind” (Csikszentmihalyi, 2007, 13). This paper is meant to monitor and interpret the specific *effects* in the sphere of emotions developed in the exchanges of significations and in the negotiations between the two casting subjects, the actor and the director. The hypothesis of my research is that the emotional load of this *limit-encounter* triggers a series of states and phenomena likely to generate subtle transformations at both of the “actors”² of the situation.

² Obviously, here, the word “actor” has the sociological meaning of participant.

Before we map the emotional universe of the casting process, we should consider several preliminary ideas on the process as such: the casting is when the director's gaze makes the first contact with reality. The character, envisaged according to the director's reading of the text, become actual possibilities, *avatars* – the dictionary definition – i.e. “unforeseen (and tormenting) transformations that occur in the evolution of a being”. The director's behaviour during the *perception* of the other (the actor) is directly linked with his/her expectations generated by the initial view on the performance. Therefore, in a first phase, the actor is classified and assessed depending on the director's interests, purposes and needs. If the actor, in aspect or reactions (e.g. is strikingly tall or has a noisy laughter), does not catch his/her eye, or if the director is constrained (e.g. he/she has a migraine which prevents the examination), the process that leads to the shaping of the impression will be interrupted and the assessment will rely mainly on information specific to the (human or professional) category in which the examined individual is included from the start. If specific factors stimulate the director to assess also personal traits of the actor, the resulting impression will be toned. Once the image is formed, there is a tendency that the subsequent information on that individual be processed toward the consolidation of the already shaped impression. On the other hand, the actor may initiate actions or adopt behaviours meant to influence the director. This is how the future performer is not necessarily in the position of the one whose fate is decided. As noted by Erving Goffman, the actor may wish them to think highly of him, or to think that he thinks highly of them, or to perceive how in fact he feels toward them, or to obtain no clear-cut impression; he may wish to ensure sufficient harmony so that the interaction can be sustained, or to defraud, get rid of, confuse, mislead, antagonize, or insult them. (Goffman, 2007, 32)

Therefore, his interest is in the control of the others' attitude and, especially, behaviour by which they react to his presence. The “reading” of the reactions triggered by his performance will act as a guideline for the actor to adjust his own actions; it is an indispensable feedback. The actor wants to reach his purpose (get the part), but, since the audition installs a living, condensed, dramatic relationship, everything projected by the actor before the casting can change depending on the director's reactions and indications.

I have attended recently a casting session led by a ludic, careful and kind director. At a certain point, a young actor, whom I knew was talented, rational, and educated, appeared in front of the director. “Their discovery of each other will be wonderful”, I thought. Unfortunately, the meeting was a modest one: the young actor seemed dispirited; he read unconvincingly, his interpretation was amorphous at the director's patient indications. Obviously,

the role was cast to someone else. Intrigued by this episode, I had a subsequent talk with the actor. He confessed his emotions got in the way. When he assisted the auditions of actors before him, he heard the director say to another actor to moderate his interpretations. Therefore, he became obsessed with the idea that he would also have to make economy of movements and of changes of attitude. Emotions are paradoxical. On the one hand, as stated by Mihaly Csikszentmihalyi, they are

...in some respect the most subjective elements of consciousness, since only the person him/herself can tell whether he or she truly experiences [...]. Yet an emotion is also the most objective content of the mind, because the 'gut feeling' we experience when we are in love, or ashamed, or scared, or happy, is generally more real to us than what we observe in the world outside, or whatever we learn from science or logic. (Csikszentmihalyi, 30)

Emotions can be controlled or led in a direction to stimulate the actor's performance, for example by techniques that involve attention. *Attention calibrates emotions*, finds psychologist and scientific journalist Daniel Goleman. Starting from this assertion, we can imagine the following scenario: we are at the beginning of the casting session. The actor is in the audition room, the first eye contact has been made, and the first impression has been shaped on both sides. Now, the actor's emotions are very strong, he hasn't heard his voice yet and the following actions are still undefined. If he took Goleman's advice, the highly excited actor would direct his attention to something concrete, different from his own "limit-situation". On the other hand, the director, who can see the actor's intense emotions and who, obviously, wants them cleared, to allow him to see beyond them, should give the actor a concrete indication that could gather the actor's full attention to a specific point. This trick is in fact the activation of the mechanisms of *selective attention*, to "calm down" the anxious amygdala³. As long as his attention is caught by something else, the emotion of the "supervised" individual disappears. But if this attention drops, than "the emotional distress, if still kept by the amygdala neural networks, comes roaring back." (Goleman, 2013, 87) For example, if the director opens the conversation and asks the actor to pick, from a table, an object to be used in a first improvisation, his attention will be fully focussed on the fulfilment of the received task. Back again in front of the commission, if he does not receive immediately the following indicator, the actor will begin to wonder whether he

³ *Amygdala*, a primitive area of the brain that controls gut reactions to events we experience; it is responsible, among other things, with the production of instinct behaviour.

chose the right object. Perhaps he should have picked something bigger or something that could be held more easily with one hand. Such questions will continue to arise and the state of distress will be reinstalled.

Let us imagine another hypothetical situation. If there is an object in the casting room, for example a fur coat down by the director's chair, this may give to an actress who fears dogs the feeling there's a dog there - and this idea may stir moods or reactions that reason cannot control. It is what Joseph LeDoux, cited by Daniel Goleman, calls *precognitive emotion*, hence a reaction based on "fragments of sensory information that were not stored completely and were not integrated in a recognisable object". (Goleman, 2008, 53) The amygdala is the one that senses this *sensory pattern of import* (Goleman) and it draws a conclusion that triggers reactions even before the fact is confirmed. The phenomenon is called by Goleman *the dark side of our raging emotions*, emotions with which actors work frequently.

If an actor exits the casting room discontent and furious, the one following him is burdened with strong emotions that will vanish only if he is welcomed in a calm, natural environment.⁴ Essentially, feelings are indispensable to rational decision-making, believes neurologist Antonio Damasio, professor at the Iowa University, introducing the concept of "emotional brain". *The rational brain*, claims Damasio, has a leading role at the level of emotions, with the exception of the times when emotions cannot be controlled and the *emotional brain* goes haywire. (Goleman, 58) Although emotions dominate the actor's state when he enters the casting room, the information he obtains by the quick analysis of the environment can appease him immediately. Ana Tkacenko, an actress in Chisinau, tells the story of such a change of state she experienced at an audition organized by the Bucharest National Theatre: "My legs were shaking just before my turn came... When I least expected it, I had to go in and the change as such began..." (Andronescu, 2013, 327-328). For her, the emotions were appeased when she looked at the director and felt he was a "normal and kind" man. The physiological explanation of emotions shows that, in a distressing, intensely emotional situation (such as the casting), a nerve that starts from the brain and reaches the adrenal glands triggers a discharge of hormones, i.e. epinephrine and norepinephrine which flow through the body and give the signal a "limit state" is at stake. Owing to a long series of chemical processes in

⁴ "When the amygdala works by preparing a distressed reaction, another part of the emotional brain enables a more adequate and more correct reaction. The brain bumper goes from the amygdala, which seemed to have lied, to the other end of the major circuit, i.e. the neocortex, the frontal lobes, (...) mastering the feeling for a more efficient reaction". *Ibid.* p 54

the actor's body, the actor will keep the memory of an important moment in an extremely energetic form⁵. As an example, I will evoke an episode in the biography of actor Florian Pitiș, recounted by the actor himself in an interview. Twenty years and more after this debut at the Bulandra Theatre, he remembered in detail how he received his first role while he was working as an electrician at the theatre:

On 24 February 1962, the actor of a small part in *As You Like It* was not available. Petre Gheorghiu told the director, "I know someone who knows the play by heart" (because I had seen it 232 times!). They summoned me from home and, in the cabin, before the performance, Liviu Ciulei worked with me on that small part for 20 minutes. (Dragnea, Băleanu, 1984, 178)

As to the director's emotion, it is conditioned by the actor and his actions. When something surprising happens - for example if an actor, in aspect and in act, exceeds his expectations – it is very likely that the director, too, experiences emotions. Since the casting is an endurance test (director Tompa Gabor, for example, recounts a casting with 310 actors in 8 days at the Lliure theatre in Barcelona), the overwhelming amount of data blends emotion with fatigue. A casting process may result in a troubling finding at the last moment, or it may lead to an overload of useless information and less fortunate choices. The decision (or the awareness that the circumstances overwhelm you) appears, say neuroscience studies (Goleman, 162), in the prefrontal region of the brain, the one that operates the executive functions, such as organisation, planning, forecasting or self-monitoring.⁶ When a threshold is reached, this part of the cortex no longer resists, and the decisions and choices get out of hand as anxiety and fatigue increase. To avoid getting there, the director should apply selective attention, follow a number of sources he can manage and ignore the rest.

Intense emotional states, experienced in childhood, act directly on us, make us more flexible or, on the contrary, more unstable in relation with the people we meet or the events we witness. Emotions are urges that prompt us

⁵ The following mentions are taken from Daniel Goleman, *Inteligența emoțională*. The amygdala is the main place in the brain where these signals go; they activate the neurons in the amygdala nucleus, which send signals to other regions of the brain in a way that will improve the memory of what is happening. This awakening of the amygdala nucleus seems to print on the memory most of the intensely emotional moments, with additional strength. p. 49.

⁶ The four functions of the brain are taken from <http://www.psihiatrietimisoara.ro/material/cortexul.pdf>

to act, each emotion⁷ readying the body for reaction. People in general (actors, too) fall either under the spontaneous-intuitive type or under the rational-intellectual one; they approach situations differently in order to meet their objectives. At those who rely on reason, the *downward* neural steering is primary, according to Goleman, where *spontaneous attention, will and intended choice* are activated. Those who rely on intuition use first of all their instinct and then *reflexive attention, routine habit and impulse (urge)* are intensified, corresponding to an *upward* neural activation. Selective attention is also different, depending on one's typology. For the intuitive person, whose attention system starts from instinct and goes to reason, information comes from the closer or more remote outer environment, sometimes not yet in the area of interest of total focus; the mind analyses what is in the field of perception before knowing what it will select as important. Let us imagine the following situation: if from the building adjacent to the room where the casting process is in progress bouncy music can be heard, it is possible that an "intuitive" actor borrows, even unaware, the perceived rhythm in his improvisation. The rational actor's mind accesses more easily the selective attention which starts from reason and goes to instinct, but it requires more time to decide what piece of information it can choose from the surrounding sounds, to identify each piece of information and to make decisions once they are analysed in full. For the same example, the rational actor could retain a specific instrument from the music heard in the distance, and then he could use the image or the name of the instrument in his improvisation. Thus, in the reason – emotion relationship, the conclusion is easily conceivable: the more intense a feeling is, the more the mind will be dominated by emotion and more inefficient rationally speaking. For instance, if during a casting session the director decides to test the candidate's coordination skills in an "opposite vectors" exercise⁸, and the latter makes several successive

⁷ To understand better the power of emotions on thought, we have taken several pieces of information from Daniel Goleman's *Emotional Intelligence*, on how the brain has evolved. "The most primitive part of the brain is the brainstem surrounding the top of the spinal cord. This root brain regulates basic life functions like breathing and the metabolism of the body's other organs, as well as controlling stereotypes reactions and movements. From the most primitive root, the brainstem, emerged the emotional centres. Millions of years later in evolution, from these emotional areas evolved the thinking brain or "neocortex". The thinking brain grew from the emotional, there was an emotional brain long before there was an emotional one. (...) The neocortex is the seat of thought, allows for the subtlety and complexity of emotional life, such as the ability to have feeling *about* our feelings", pp. 38-39.

⁸ "Opposite vectors" is a special category of exercises that explore the possibility to make simultaneous movements (opposed in direction, pace etc.) with different parts of the body. Known as "opposite vectors technique", these exercises require focus and the division of the actor's attention.

mistakes, it is possible the actors no longer manages, later, to fulfil any simple task. Balance between the emotional life and the rational one is given by the fact that, usually, "emotions feed and inform the operations of the rational mind, and the rational mind refines and sometimes vetoes the inputs of the emotions."(Goleman, 35-36) Reason cannot, however, oppose strong passions that cause an imbalance, when emotions takes control and stifles it.

During a casting process, actors improvise. By improvising, the actor creates stories, fictions, illusions with images and sounds. The actor's mind is like a machine that absorbs real images and sounds which it then mixes and restores them transformed, mysterious or humorous, more dilated or more compressed, but definitely more energetic. When the actor comes to a "halt" (blocking), it will generate a state of panic, the information travels fast an emergency route, from the eyes and the ears to the thalamus and then to the amygdala nucleus. According to traditional scientific theories, the eye, the ear and the other sensitive organs (skin, tongue etc.) transmit information to the thalamus and from there to the neocortex, *the thinking brain*. Pioneering research by professor Joseph LeDoux led to the finding of a small group of neurons that carry the information from the thalamus straight to the amygdala nucleus, the one that signals the emergency state and concentrates the remaining parts of the brain on this situation, before the neocortex has any opportunity to analyse completely what is happening and to decide how to act. Thus, time is saved in situations that require an immediate reaction. From this, the thalamus-amygdala circuit sends only a small part of the sensory message; its largest part goes to the neocortex. The neural outcome of this special situation is that, once the corresponding moment expires, those who experienced it are like "possessed", they cannot tell what happened to them(Goleman, 42). Such a moment is recounted by stage director and instructor David Zinder in an interview:

I've been teaching for nearly thirty years and in this time my memory has retained four or five experiences with my students. Many years ago, one of my students in Tel Aviv performed an amazing, bright exercise with a rope. For almost half an hour she worked with the image of the rope. We were all out of breath, watching her: no "mistake", if we could speak about mistakes in an improvisation! After each creative decision she made, I would find myself think, yes, that's ok, that absolutely ok! The solution was correct but not only she was doing what matched a series of prescribed rules, but because she could surprise me, everything was integrated organically with what she was proposing, there was continuity. Moreover, it was obvious she was feeling very well [...]. At the end, I asked her what she remembered. She told me she remembered nothing

with the exception of a feeling of infallibility. She had felt like me that she couldn't do wrong. She didn't remember a thing. (Zinder, 2011, 115-125)

Once they exit an emotionally challenging environment, such as a casting process or a competition, actors often state that they cannot remember anything, they cannot say how they made this or that decision, why they began all of a sudden, without thinking, to cry, to laugh, to scream etc. It seems the amygdala nucleus is responsible for strong emotional reactions that emerge without the participation of the conscious; it acts like "an emotional sentinel able to hijack the brain when the impulsive reaction overwhelms the logical one", states LeDoux (Goleman, 46). Borrowing the information on the *amygdala* from LeDoux's studies, Goleman also approaches "this smaller and shorter pathway that allows the amygdala to receive some direct inputs from the senses and start a response *before* they are fully registered by the neocortex". (Goleman, 184) Therefore, feelings, sensations that take the path of the amygdala and trigger a quick, irrational reaction are usually the most primitive and most powerful ones. Often, the force of the emotion experienced by an actor during casting overwhelms the rational because of the great thing at stake.

To enable the manifestation of his creativity, the actor needs to exceed the *emotional hijack* caused by the fear of making a mistake or by discouragement, in case of negative feedback. Indeed, if the messages received from the director are negative, cervical level neural areas are activated, and this generates anxiety, contradiction and sadness, states which lead to a defensive attitude or to inhibition (Goleman, 184). From my own directing experience and from the observation of other directors, I have found the importance, in casting, of voice inflections and tones, when a suggestion/conclusion is offered. Research in this direction has shown that the "acoustics of our skull case render our voice as it sounds to us very different from what others hear. But our tone of voice matters immensely to the impact of what we say." (Goleman, 81) If feedback is negative but the tone of the director's voice is pleasant, warm, the actor will experience the criticism constructively. However, if the director talks about the good things he saw, but involves a cold and distant tone of voice, the actors will experience the feedback negatively. If the actor is told that what he acted was not alright, the bad state that may appear pushes him to a restricted sphere of thoughts. On the contrary, if his state is good, he extends the span of his attention and his perception changes. According to Richard Davidson, professor of psychology and psychiatry at the Wisconsin-Madison University, the actor's state of wellbeing "activates the nerve centres at the left prefrontal part of the brain, a sphere that includes the nervous branches that remind us the pleasant feeling we have when we manage to do what we are set to do." (Goleman, 182)

“Attention works, in general, like a muscle – if it is not used, it start to atrophy” states Daniel Goleman. (Goleman, 14) In most actors, the training of attention is permanent. However, the distraction of attention may occur both at an emotional level (for instance, when the fear of failure emerges) and at a sensory one (if a physical discomfort or pain appears). To maximise his odds and to avoid fatigue and inefficiency due to the effort during an audition, the actor needs to learn how to discipline his attention. In its usual state, mental information is somewhat disordered; thoughts appear and disappear. If the actor’s attention is not trained, errors, confusion, and irritation may appear and lead to the decrease of the power to focus and, therefore, the casting purpose can be missed, and the directors may make inappropriate choices. Daniel Wegner, professor of psychology at Harvard, studied errors and how they alternate depending on how careless, stressed or tense we are. According to Wegner, in limit-situations, “a cognitive control system that ordinarily monitors errors we might make can inadvertently act as a mental prime, increasing the likelihood of that very mistake.” (Wegner, 48-50) For example, if the actor is set not to mention he interpreted, in another directing effort, the role for which he is at the casting, perhaps he will do just that. Edgar Allan Poe called the mental tendency to reveal a sensitive topic one does not want to bring up “the imp of the perverse”.

In casting, focusing in the required direction is the director’s fundamental task. Sometimes, essential information may be found in a movement of the hand, in a specific way of delivering sounds or in a specific movement of shoulder, for example. The director’s talent is also expressed in his capacity to steer the attention toward the right direction, at the right time, while guessing some defining traits of some actors. If the actor lacks focus, his capacity to comprehend is also compromised. The solution, offered by Goleman, is *meta-awareness*, attention to oneself, similar to the capacity of *observing that you are not observing* and redirecting attention to what you were set to. When the actor is focused, attention on himself may diminish, and the mind is freed from the thoughts that concern the self, which enables the activation of the circuits that support his intentions.

The casting is a communicational process made from a complex network of information exchanges organised at multiple levels. Valuable information can be obtained both by the director and by the actor from the postures of the body, which validates the examination of the other during the interaction. In the actor’s communication with the director, any of them may convey some *other* type of (energetic or cognitive) information than the information put in words. Since they are involved in a permanent communication at two levels

(verbal and nonverbal) the actor and especially the director need to be careful about reciprocity and harmony. The director, primarily an *observer*, needs, therefore, to extract and to select information both from the actor's behaviour *in the role* (professional skills) and from the behaviour of the individual in front of him (traits, feelings, states). Lev Dodin, the well-known Russian director, would note that, paradoxically,

in fact, many actors are shy or even closeted, and most of the people mistake freedom on stage for freedom in real life. I have seen that, the more detached you are in your everyday life, the more inhibited you become on the stage, perhaps because energy is wasted at the outside and it is not carried within on the stage. (Dodin, 2008, 18)

The most revealing sources of the nonverbal behavioural keys for the actor who is not in the role are: body language, eye contact (the sight) and voice. Many other pieces of information can be obtained from an analysis of gestures, of the gait, of posture, of pace and of the flow of various movements. On the other hand, the director is never corporeally passive; instead he runs a "secondary" performance in front of the actor. When he likes it, he relaxes, he smiles, and even replies. When he does not like it, he may twitch, he is fidgeting, he is coughing; he is obviously at a loss. There are cases where the director gives the line to the actor, which commits him, unwillingly, to the interaction; the two are interdependent, involved, and energetic, some other times quiet, a two-headed spectator.

Various studies have shown that actors and observer-directors do not hold the same information; actors have more pieces of information on their own behaviour and on the justification of their act and they are used to shaping their nonverbal language based on their purpose. Therefore, the actor and his observer evaluate a situation from different points of view: the observer is interested in the action to unravel, while the actor focuses on the specificity of the situations in which he is involved. One of the many of the director's purposes in casting relates to the actor's image on himself, to his attitude toward his own skills. In the end, the actor is his future partner in an inscrutable journey. If he does not know the actor, the director may obtain clarifications from the attitude and appearance of the one he observes, which, at an intimate level, makes him update his previous experience with more or less similar individuals or apply unverified stereotypes. The actor may represses his immediate actual feelings, by sending a perspective on the situation of which he thinks the other will find acceptable, at least for a

while. This superficial agreement is enabled by the fact that each participant is able to conceal their own intents behind value-based statements followed by everyone in attendance.

The director's action, however, concerns frequently the actor's *person*, the one in the extra-professional environment, the environment of his private existence. To this end, more often than not, the director will have a skewed, evasive approach rather than a direct, frontal one. The director's tricky behaviour tries to grasp the actor's real human essence, but the director may allow himself, deliberately, to be contaminated and seduced by the actor's vital strength. In front of the actor's performance, the observer-director is in a paradoxical situation resulting from his dichotomous condition: detached observer and at the same time committed participant. He needs to be simultaneously *within* and *without* the event, to allow himself to be "stolen" by the "object" of his observation (the interpretation, the acting), as well as not to misplace the "plan", the "chart" of the upcoming performance; the director needs to obtain information and to trust the reality of the things that may surface when self-control wanes. The casting process can be the first meeting place of a director and his future "fetish actor", a first revealing intersection, a fulfilment of an expectation, a state similar to falling in love, a fateful encounter.

References

- Travelling Academy. Andrei Șerban. Cartea Atelierelor*, volume coordinated by Monica ANDRONESCU and Cristiana GAVRILĂ, preface by Horia-Roman Patapievici, Nemira, 2013.
- BANU, George, *Scena supravegheată. De la Shakespeare la Genet*, translation by Delia Voicu, Polirom, 2007.
- CSIKSZENTMIHALYI, Mihaly, *Starea de flux: psihologia experienței supreme*, transl. Monica Tudora, Cartea Veche, Bucharest, 2007.
- DODIN, Lev, *Călătorie fără sfârșit. Reflecții și memorii*, ed. by John Ormrod, foreword by Peter Brook, transl. from English by Cătălina Panaitescu, "Teatrul azi", series "Mari regizori ai lumii", Bucharest, 2008.
- DRAGNEA, Doina, BĂLEANU Andrei, *Actorul – între adevăr și ficțiune*, Meridiane, Bucharest, 1984.
- GOFFMAN Erving, *Viața cotidiană ca spectacol*, Comunicare.ro publishing house, Bucharest, 2007.

GOLEMAN, Daniel, *Focus-motivația ascunsă a performanței*, translation from English by Iustina Cojocaru and Bogdan Georgescu, Curtea Veche Publishing, Bucharest, 2013.

-*Inteligența emoțională*, 3rd edition, translation from English by Irina-Margareta Nistor, Curtea Veche, Bucharest, 2008.

WEGNER, Daniel *How to Think, Say, or Do Precisely the Worst Thing for Any Occasion Science*, 3 July 2009, pp. 48-50.

“*The Deconstruction of the Improvisation in the Actor’s Training. A Dialog with David Zinder*”, interview by Filip Odangiu, in “*Studia Universitatis “Babeș-Bolyai”. Dramatica*”, no. 1, 2011, pp. 115-125.

DIANA ALDEA is a stage and film director, plastic artist, graduate of the Audio-visual Programmes MA of U.N.A.T.C. “I.L.Caragiale” Bucharest (2008), of the section of Stage Directing at the Faculty of Theatre in the Babeș- Bolyai University, Cluj (2004), as well as of the Painting-Restoration specialisation at the Faculty of Orthodox Theology, Babeș-Bolyai University Cluj (2000). Her activity includes theatre and dance performances, directed in the Romania and abroad, teaching and exhibitions, with numerous paintings in private collections in Romania and abroad.

“Each of us at Cricot-2 had their own personal Kantor”

**Interview with Teresa and Andrzej Welmiński,
renowned actors of the Cricot-2 Theatre**

EUGEN WOHL*

ABSTRACT: The present interview with Teresa and Andrzej Welmiński, actors of the Cricot-2 Theatre, has been conducted on April 8, 2015, one day before the presentation to the public of their three week workshop with the students of the Faculty of Theatre and Television, Babeş-Bolyai University of Cluj, Romania. The discussion is centered on the artists' collaboration with Tadeusz Kantor and the Cricot-2 Theatre, the history and stage practices of the Polish company, as well as on the artists' current and future projects.

Key words: Tadeusz Kantor, Cricot-2, Polish Theatre, theatre workshops.



Fig. 1: Teresa Welmińska (right) and Andrzej Welmiński (upper left) with actors of the production *Against Nothingness*, 2014. Copyright: Teresa and Andrzej Welmiński

* Postdoctoral Researcher and Teaching Assistant, PhD, at the Faculty of Letters, Babeş-Bolyai University, Cluj-Napoca, e-mail: eugenwohl@gmail.com

Teresa Welmińska is an actress and director. She is a graduate of the Higher Medical School for Nurses in Cracow. From 1976 to 1990 she worked with Tadeusz Kantor and performed in the following productions of the Cricot-2 Theatre: *The Dead Class*, *Where Are the Snows of Yesteryear*, *Wielopole*, *Wielopole*, *Let the Artists Die*, *I Shall Never Return* and *Today Is My Birthday*. Since 1992 she has been working on theatre productions and running theatre workshops along with Andrzej Welmiński.

Andrzej Welmiński graduated from the Faculty of Graphic Art of Cracow Academy of Fine Arts (degree at professor Kunz, 1977). He is involved in drawing, painting, photography, creates objects and installations, he is an actor and theatre director. A close collaborator of Tadeusz Kantor and member of the Cricot-2 Theatre, from 1973 to 1990 he was a part of all of Cricot-2's world famous theatre productions. Together with his wife, Teresa, he is currently giving lectures and conducting workshops on the history, theory (philosophy) and stage practices of the famous Polish theatre.

Eugen Wohl: *You met Tadeusz Kantor in 1970, but it took another three years for you to join the Cricot-2 Theater. How was your first encounter with Kantor and how did you eventually decided to join the company?*

A. W.: Yes, it was quite a distance. I was very young, at that time I was studying at the Secondary Art School in Cracow. By then, I was already quite positive I would become an artist, that this was something I was going to do for the rest of my life, and Krzysztofory and the group of artists gathered around that café represented the most radical center of modern art in Poland in that deep socialism time. It was also a window to the world; those people had the possibility to travel, to bring in new ideas from Western Europe, from other countries, from the USA, new artistic movements, and so on. Of course, as a young boy I was fascinated with all that and I used to go to all the exhibitions, all the theater performances and happenings, all the activities which were in that place. The other place was related to this one, but I learned of it only a little later, it was the Foksal Gallery in Warsaw. Those two places were connected by the same people, who were in charge of them. I soon realized that I would like to work with those people, it became almost imperative. So, one day I decided to ask Tadeusz if I could organize an exhibition of my works and he said "yes, yes, maybe". All his life he was very friendly and he advocated for a relation of partnership between artists; he never considered himself the only authority, and in conversation it seemed there was no age difference between us. Tadeusz was older than my parents, but the relation, contact and mutual understanding

between us was very simple and easy, and so was my starting point. During our first meetings and talks I was allowed to be there with the other members of the group, I was allowed to sit at the same table with them and it was really interesting, because the discussions at the table were really fantastic. So, for me it was something amazing. Very soon, me and another friend of mine, Romek Siwulak, we started working together and we made a happening. Kantor was invited, but we didn't expect him to come, because it was an outdoor location, on a huge meadow in Cracow. And yet he came and a few years later he wrote his description of that happening. The happening was called *Morning Happening or The Yellow Suitcase*. We started to make exhibitions of our own works, and in those first few years it was mainly collaboration concerning the art of painting. But of course, everything was mixed already by then, so when the performance *The Water Hen* returned from Edinburgh, I recall, I was helping with the reconstruction of some objects that were usually damaged during the tour. So, at the time, I participated in all the rehearsals. And so it is on my encounters with Tadeusz Kantor those days. You asked also how I got into the theater, didn't you?

E. W.: *Yes, please tell us a little bit about your transition to theater.*



Fig. 2: A. Welmiński: *yellow suitcase – documentation of the morning happening / 1970*. Copyright: Teresa and Andrzej Welmiński



Fig. 3: A. Welmiński: *documentation of the morning happening / 1970*. Copyright: Teresa and Andrzej Welmiński

A. W.: Some actors couldn't go on the tour to Edinburgh, and therefore my first role was in *Lovelies and Dowdies*, but before that I was designing, together with some of my friends, all the signs that were put on doors and on huge billboards during the performance. My role was "The Gipsy", I was playing the violin in *Lovelies and Dowdies* and after that I played "Sir Grant" who seduces Princess Zofia, the Duchess of Kremlin, with a very special aphrodisiac, some pills he produced himself and which proved to be deadly poisonous. So this was my first theater role.

E. W.: *Teresa, you decided to join the Cricot-2 Theater in 1976, but before that you prepared for a different career, as a student of the Medical High School in Cracow. How did you make this transition from medicine to theatre?*

T. W.: Yes, it was the Higher Medical School for Nurses. I was simply seduced by the performance *The Dead Class* at the Krzysztofory Gallery. So I started going to this café. As the stage was nearby, I had the opportunity to listen to these very interesting conversations about art, about theatre, taking place between Kantor and Kazimierz Mikulski, Zbigniew Gostomski, Janina Kraupe-Świdorska and other great artists who were working in the theater, apart from developing their own, individual artistic projects, and who were all connected in some way to the Grupa Cracowska (The Cracow Group). I also participated in those discussions mentioned. One day, in his studio, Tadeusz Kantor was talking about his work and asked me if I would like to play the role of the female sutler in *The Dead Class*. Sutlers were the women who used to follow the army during wartime. Some of them were the wives of the soldiers, others were just prostitutes, but they would always follow the soldiers everywhere and assist them with cooking and other chores. They were also wartime nurses and, when necessary, they would behave as mourners for the deceased soldiers. So Kantor wanted this character to convey the multiple facets of such a person. I succeeded in creating this character to Kantor's liking and this was the beginning of my collaboration with Cricot-2 Theater.

E. W.: *So this was the beginning of the journey... My questions from now on are for both of you. You mentioned the fact that during the Communist Regime in Poland, Cricot-2 Theater somehow had the possibility to travel abroad. How was the relationship with the authorities and how did they perceive the activity of the Cricot-2 Theater?*

A.W. & T.W.: The members of the Cricot-2 Theater and most of the members of The Cracow Group, not all of them however, – this happened in the 50s, before I met Kantor – were the few artists in Poland who totally refused to adhere to Social Realism, which in those times was an impossible task. As a

result, most of them became outsiders, nobody could make an exhibition, they were frozen. Kantor was one of them. So, when things began to liberalize in the late 50's and in the beginning of the 60s, to such an extent that even jazz could be played, they resumed their activity. But before that they had basically been a reaction group. But your question was how it was possible for them to travel? At the time these artists were already well-known, even earlier they used to travel to Paris, and Kantor himself went to Paris and New York. Of course, it was always difficult to obtain a passport because it could only be done through the ministry, and in some occasions his passport request was even denied. So it was not easy. But I think that one of the most important persons involved in Cricot's possibility to travel abroad was Richard Demarco. He wanted to invite Eastern European theatre artists to the Edinburgh Festival, artists completely unknown in the Western world, and he travelled a lot to the socialist countries in his pursuit. In Poland he visited Foksal Gallery in Warsaw and Wiesław Borowski told him he should see the Cricot Theater in Cracow. He came then and saw *The Water Hen* and he decided that he had to have this performance in the festival. But since the ministry had the final word, it said "no, we do not know of such a theater, but if you would like to have an alternative theater piece in your festival we suggest you invite Grotowski". However, by that time he was already quite accustomed to Polish cultural life and relations and he answered "No, I would like to invite only Cricot-2 Theatre or none." So, finally, after a lot of discussions and impediments, he managed to invite Cricot-2 and this was the beginning. After Edinburgh great many other invitations came from other important capital cities and important festivals and it became impossible for the Polish government to refuse them. Therefore, it's safe to say that the pressure from the outside made everything possible.

E.W.: So *The Water Hen* represented and international opening for Cricot-2. However, it was 1975's *The Dead Class* which represents a defining moment in the theatre company's success. While working on this production, did you have the feeling, did Kantor have the feeling, that it was going to be such a worldwide phenomenon, that it would have such an enormous success?

A.W. & T.W.: Yes, we had such a feeling. We already knew a lot of events that had happened all over the world, we were familiar with the main tendencies in art and theatre. Yes, we were absolutely conscious that it was something very new, very special, a totally different way of thinking about art, so it was not surprising when a big group of AICA (The International Association of Art Critics) members, invited to see the performance by the Ministry of Culture, asked if there was any possibility to see the rehearsals – at the time the

performance was not finished, so we presented only half of *The Dead Class* – and they were bewildered, they were shocked with what they saw and we became sure the production would be very successful. It was something different, it was not even theatre, and we presented it as something different than theatre, it was something closer to visual art, but not a *happening* which had been one of the former kantorian creative stages, it was much more like a spiritualistic séance but held in reality. And also in that séance participated persons who were no longer with us, e.g. Mózgowicz (Tumor Brainiowicz). So it was a play with them, it was not theatre, it was a different genre.



Fig. 4: A. Welmiński: *Chilled one*, from the cycle: *Fairy Tales*/1985. Copyright: Teresa and Andrzej Welmiński



Fig. 5: Andrzej Welmiński: *small wooden crucifix...*/1990. Copyright: Teresa and Andrzej Welmiński

E.W.: *And did you know then what that different genre was, or did you just feel that it was not theatre? How was the production process, did you start from the idea that “this is not going to be theatre”?*



Fig. 6: Andrzej Wełmiński: Bike from the album “trumpf, trumpf”.
Copyright: Teresa and Andrzej Wełmiński

A.W. & T.W.: No, no, from the beginning and when I became a member of the company, the Cricot-2 Theatre was something different in comparison to the other theatres, even alternative theatres. Now I think it was something linked to Witkiewicz’s idea of non-representational theatre. From the very early beginnings and from Kantor’s writings we knew that what we were doing was not the representation of any characters, it was not staging literature, but something more, a very special relationship with the text – the text was not eliminated, Kantor wanted the text there – which was considered a very important element, but only that, an element equal to other elements and the performance itself. This was true from the very early beginnings, for *The Water Hen* and *Lovelies and Dowdies*, but much more so for *The Dead Class*. The production was an independent work, but very collective at the same time. As for myself all this was much closer then to what was happening in the field of Visual Arts, like Joseph Beuys’ works, like some events from the great many artistic movements of the 70’s, like *Body Art*, which later became known as the *Performance Art*, or *Conceptual Art*, which was a very important movement. It was like translating a lot of modern, radical artistic ideas into the field of theatre. You have to remember that Witkiewicz himself was first of all a painter and he was absolutely against conventional theatre. In one of his writings he opposed his own idea of theatre

to Stanislavsky's ideas, which were very well known and important even before the war, saying that he refused the idea of representation, of experienced character and, instead he was much more interested in constructing forms and in formal thinking about theatre. So, I think those ideas, related to the Dada movement and to Surrealism, were also fundamental for the Cricot-2 theatre. They developed it and declared that they were doing an independent theatre and that they were seeking for the language of independent theatre, a pure theatre language which was independent from literature, as it was not a function of literature. Kantor was a follower of this idea and he was developing it throughout all his life.

E.W.: *You have mentioned the fact that it was individual, yet still collective work, and in saying so, do you mean that each of you would work on his own character and present it at the rehearsals? How were you developing your characters, for instance?*

A.W. & T.W.: It is a little bit more complicated, I think, because this collective character didn't result just from the fact that each of us was creating his own character which he or she would present to the group. The collective way of our work also meant investigating ideas. During our talks, brainstorming sessions we would call them today, some new ideas appeared. For example, one of the first ideas of *The Dead Class* appeared from a joke, let's call it. We had been talking about a lot of theatre productions which appeared all over the world, youth theatre especially, student theatre, and one of us, I don't remember now who because we were a big group, said "but maybe, in contrast, we can make a theatre of the old". And the rest of us said "maybe very old people", "maybe dying people", "maybe already dead people", so this was the starting point. Very often jokes and such discussions used to become the starting points from which the artistic ideas started to grow up. Our work was also related to many other aspects, like creating objects. Certain objects were created by some us, others were designed by Tadeusz and still the others were found somewhere and brought in. For example, in *Let the Artists Die* the idea of changing Veit Stoss' character into a carpenter resulted from the fact that we brought from Teresa's grandfather, who was a carpenter in a small village, very old and beautiful carpenter tools which he was still using in his profession. We brought them and showed them to Kantor and he said "yes, we have to change the character of Veit Stoss, he will no longer be an artist, he will be a carpenter". So it was like that, every single element was welcomed and processed, let's say, in a different way.

E.W.: *The image that most critics see in these performances is that of an amazing effect of formlessness, the productions give the impression that they constantly change form. Of course, that's only a feeling. How much work goes behind creating such an effect of ever-changing form?*

A.W. & T.W.: We used to work on a performance for a long time. Sometimes it was several months of work. In most of those performances there were great many simultaneous actions, so when viewing the performance for the first time the spectators might be focused on some actions and the next time they would see, much to their surprise, the other actions. Very often the spectators used to come several times to see the performances, because this way, by observing more and more elements, they could acquire a deeper understanding of the performance. This is one reason. The other reason is that our work would also presuppose a kind of improvisation, which was usually on a certain topic, because this is the way it usually is at the beginning. But in the process of the performance construction with the elements more and more bound together everything was becoming much more orchestrated. So, it was an orchestration. It was very difficult and very similar to what we are going through now with our students. We are going to put together a series of individual elements. We can say that our work was similar to jazz music. In jazz bands, sometimes big jazz bands, the structure is as follows: there is solo music, the solo instrument, and there is the background. After a second there is a shift, another instrument becomes the solo and the rest represent the background, it is a kind of dialogue. We used that model of jazz band very often to make this kind of orchestration. So, it was the rhythm of all of us, because there was no score, no script, this was just like during the jam sessions, where different musicians from different countries meet for the first time, and they can play their own instruments and they can make a concerto together, an orchestration based on their common language. So it was like that, each of us with his own instrument, his own element was doing this kind of orchestration at the end. From 1977 onwards, the company had not changed, so we knew each other in almost a telepathic way, and we could anticipate the answer, the response of our colleagues in a certain situation, like a very, very good orchestration. Therefore, it was even possible to make small changes from one performance to the other, a sort of inside game, not necessarily recognizable to the audience, but which was interesting for us, the collaboration that existed between us.

E.W.: *And in this artistic dialogue, Tadeusz Kantor was always physically present. Please tell us a little bit about the importance of his presence on stage.*



Fig. 7: Andrzej Welmiński: "Apocrypha"-individual exhibition Krzysztofory Gallery, Cracow. Copyright: Teresa and Andrzej Welmiński



Fig. 8: A. Welmiński: *apocrypha*, 1993. Copyright: Teresa and Andrzej Welmiński

A.W. & T.W.: Yes, his discovery, his decision to be present on stage was very clever and important. It started during the *Happening* period and in his theatre he was present on stage for the first time in *The Water Hen*. But in his *happenings*, he was one of the most important European *Happening* creators, as the author of his own *happenings* he was the main actor, he took part in all of them. So probably this tendency to be on stage with his actors derived from his *happenings*. In the further development stages of the Cricot-2 Theatre the purpose of his presence on stage had changed of course, but he was present on stage in all of his performances up to *Today is My Birthday*. Unfortunately he died during the rehearsals of this last performance, but his presence was still symbolically very important, because this last performance, *Today is My Birthday* was about his presence.

E.W.: Yesterday, during the public meeting at the Cluj-Napoca National Theatre celebrating the centennial anniversary of Kantor's birth, you spoke about the fact, and I thought it was a splendid image, that all the members of the Cricot-2 Theatre had "their own personal Kantor". Please tell us something about "your personal Kantor".

A.W. & T.W.: Like Teresa says, I think that each of us at the Cricot-2 Theatre had his own personal Kantor, his own image of Kantor. Because each of us, each of his friends and collaborators, understood him filtered through his own personality, depending on the relationship each of us had with Tadeusz

Kantor. These relationships varied for different people, so even today there are very different opinions on Tadeusz. Some might say that he was cruel, that he was very authoritarian, but for Teresa it was one of the greatest honors to have met him and to have had the opportunity to collaborate closely with him. We were both very close to Tadeusz and his wife Maria, and we became very close friends, spending even our free time together, going together on holidays. He was there when our children were born, he was close to our family. Even Andrzej Kowalczyk, Teresa's brother, joined the Cricot-2 Theatre. So, we were a family inside the Cricot family, to some extent like a Circus family (*they laugh*).

E.W.: *That's a very beautiful image!*

A.W. & T.W.: But there were other families as well, Mira Rychlicka and her husband Stanisław Rychlicki were with the company from the very beginning, from 1955. Very often their son would accompany us on tours. Also there were the twins Lesław and Waław Janicki and their wives, who used to travel together with us, Jacek Stokłosa and his wife. So it was like that.

E.W.: *You mentioned the Cricot-2 family, and I have noticed in your biographies that after 1991 you mention some productions with the members of the Cricot-2 Theatre, but never with the Cricot-2 Theatre itself. Did the activity of the Cricot-2 Theatre come to an end after Tadeusz Kantor's death in 1990?*

A.W. & T.W.: Yes, this is a very difficult question and a difficult answer. Because we did want to continue. We were a very strong group of artists and we wanted to continue our activity. But there were some forces, I don't know where from, some forces from institutions – as you know, Cricot-2 was never an institution – and it was also related to the political changes taking place at the time. So, the subject of political change became very important. The Ministry of Culture had absolutely no interest to continue. Previously, the original Cricoteka was called “The Center of the Cricot-2 Theatre”. Later the mention “Archives” was added to its name, but its main function when Kantor was still alive was to be a mediating institution between the terrible bureaucratic machinery and art. We had always been independent, free, not affiliated to any institution, today we would say we used to function as freelancers, without any connection to an institution, just us, independent artists. Very soon, I don't remember exactly, maybe one year after Kantor's death, the ministry changed the function of Cricoteka and it became a museum. As a result, it was no longer functioning as a center for the Cricot-2 Theatre. We lost all financial support. Also, the other

opposing forces emerged. There were voices saying that we shouldn't continue the activity of the theatre after Kantor's death. Regardless, without any financial support, just self-financing, the group started to work together, against those forces, against the stupidity of critics. The first thing we made was a homage for Kantor – *Lesson of Anatomy according to Kantor* - and it was a very important moment because it proved that we could work together as a group. This was followed by our first important production, *Maniacs or Their Master's Voice*, which was with twelve members of the Cricot-2 company, as well as some new members. It was a success, we received invitations from many festivals, we travelled a lot with that very important performance. Later, also without any financial support, we started working on our next production, *Amerika or Don't Look Back*, related to Kafka's *Amerika*, but adapted to our own reality. It was a new step, a very deep performance, a complex machinery, because the action was set not on stage, but on a system of balconies, a special construction with a lot of traps. After that all became even more difficult, as there was less money, there were less possibilities, and we started to work for the other theatre companies, but for us it was interesting to see how we could spread those ideas, how we could transfer them to the other theatre troupes. This was an endeavor full of surprises, but let's just say it's quite another story (*Laughs*). But we regarded it as an opportunity to share, to proliferate knowledge about Cricot-2.

E.W.: *And to this day, you and Teresa have constantly tried to share, to spread the Cricot-2 method. How do you find audiences which have not had direct contact with the Cricot-2 Theatre responding to its legacy? From your experience of working with students, how do you see them responding to this kind of theatrical experience?*

A.W. & T.W.: Like Teresa is saying, we are completely devoted to the group of people we are working with. We are at their disposal. We give them our recollections, our experience and knowledge. And we understand this work both as a collaboration with them and, at the same time, as a part of our creativity. It is like Joseph Beuys said: "To be a teacher is my greatest work of art". It's beautiful, isn't it? And he was a great teacher. Usually the results of our workshops, cannot be called productions, they are something else. To our understanding and consideration the effect of our collaboration is a part of our creativity, as well. In this respect, this relationship is very similar to the one we had with Tadeusz. Not a professor-student relationship, but a partnership, we are at the same level. At the beginning neither we nor they know what it all would be like. Our work is mainly about opening the imagination of our participants and giving them the possibility to

translate their own private images and experiences into universal images, to create a universal image. There are many different methods available, like working with metaphors, and so on. We all begin our work almost as blind men, not knowing what lies ahead, but at a certain moment we begin to understand each other and to share the common language, not a verbal one, but the one of mutual understanding. And it is a great satisfaction for us to reach that moment.

E.W.: *We are one day before the presentation of your work with the students from the Faculty of Theatre and Television of Cluj. Can you tell us a little bit about how you collaborated with the Romanian students and what we will see tomorrow?*

A.W. & T.W.: I think that just now we have reached that moment and it becomes very, very interesting. The result of our work, of our process, it would be too much to call it a performance, derives from a lot of very private stories, very often from personal stories, just like Tadeusz Kantor's *Wielopole*, *Wielopole* emerged from his childhood, but there are many such examples in universal culture, like Bruno Schulz, Gabriel Garcia Marquez, many painters, and so on. So, these stories are now coming together, are becoming a unity to some extent. The title is *Croquis from Transylvania or the Melancholy of the Black Egg*, because we are in Transylvania. This is our first visit here. There are many popular images of Transylvania, but at the same time it is still very exotic, in our point of view. Very often in our work we try to include the local particularities, the local spirit, fairy tales. In this way the result is a unique experience, impossible to repeat anywhere else.

E.W.: *Please tell us, what are the future projects of Andrzej and Teresa Wetmiński? Where will you conduct your next workshops?*

A.W. & T.W.: After Cluj we are going to work in Chişinău, in frame of the Class Fest International Festival. Then to Sofia and a few days after to Palermo. We have also been invited to La Mamma Umbria in Spoleto, Italy and Cricoteka in Cracow is planning a two week session of workshops with public presentations in the new location of the center. There we are going to work together with Andzik Kowalczyk, Teresa's brother, and some old friends from Cricot.

E.W.: *Thank you very much for this interview!*



Fig. 9: Teresa and Andrzej Welmiński
Copyright: Teresa and Andrzej Welmiński

EUGEN WOHL is a postdoctoral researcher, teaching assistant and theatre critic (IATC member) whose professional activities include collaborations with several cultural publications and translation of contemporary plays from English to Romanian. The articles and interviews he currently publishes are a result of a research made possible by the financial support of the Sectoral Operational Programme for Human Resources Development 2007-2013, co-financed by the European Social Fund, under the project POSDRU/159/1.5/S/132400 - "Young successful researchers – professional development in an international and interdisciplinary environment".

**PERFORMANCE, FILM AND
BOOK REVIEWS**

The End of Directing – A Foundation Study for Contemporary European Theatre Making

Book review: Iulia Popovici (ed.), *The End of Directing, The Beginning of Theatre-Making and Devising in European Theatre*, 2015, 327 p., ISBN : 978-606-8437-56-9, Sibiu International Theatre Festival Book Collection.

The Sibiu International Theatre Festival has developed a section of conferences, theoretic debates and book printing. Usually the festival brings to light contemporary theatre plays but also theoretical volumes, that deal with contemporary issues regarding theatre. This year, they propose a very important and expected collection of studies and interviews: *The End of Directing, The Beginning of Theatre Making and Devising in European Theatre*. The volume in question comes as a meaningful study for a market that has really few contemporary theoretical contributions regarding national or international independent production. Usually, specialists and students learn from papers or blogs what European theatre is up to. Offering a critical approach on a phenomenon that is growing every day, that of collective work in theatre, the volume is

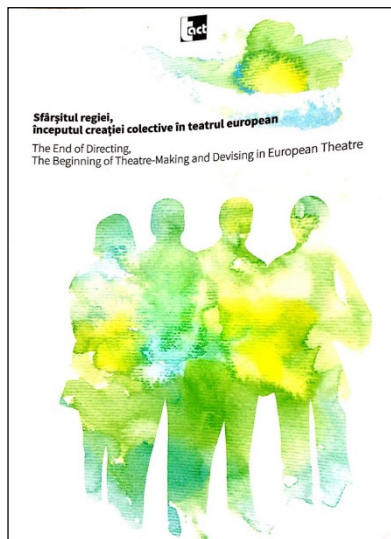

structured in two sections: studies about independent performances in specific countries and interviews with representative theatre makers.

The editor says, in the introduction section: "The difference between the European model of theatre auteurs (...) and the new theatre-makers that are equally dramatists and directors of their own scripts lies on a dual aspect. It is related both

to the nature of their working process (...) and to how these theatre makers relate to tradition."

Therefore, the book opens with a study signed by Duška Radosavljevic, writer, dramaturge and scholar based at the University of Kent, UK. Her text defines new ways of theatre making, discussing the importance of written text in performance, the developments of working with a classical text through history,

from Max Reinhardt to H. Th. Lehmann and his post-dramatic theatre. The essay also explores the classification of drama texts based on their level of independence, made by Martin Puchner. The second part of the study deals with devised theatre, a concept that has not only translation problems, but also different ways on being understood, depending on the country and the practitioners that are using it. The author underlines that: "devising must be understood by reference to its own context – as a term and as a practice". The study is finished by ten important principles of Theatre-Making, each of them explained and demonstrated as necessary during the intercession: authority, de-professionalization, self-determination, education and training, globalised workplace, collaboration – audience, actors, directors and playwriting works together.

Radosavljević's study is an extremely helpful instrument for scholars to use as a support in all debates about contemporary theatre with students.

The End of Directing... continues with three important contributions by Andreea Tompa, Iulia Popovici and Jean-Pierre Thibaudat, each of them analysing a different national contemporary development: the Romanian, the Hungarian and the French model of author-directors and devised theatre procedures. On a critical approach, each study reveals the ups and downs of a system, the liberties and coercions of different countries, the particular context in which the author-director appears – France – 1960, Romania after 1990 and Hungary around 1970. Each

article makes a short historical approach of the field, commenting around the cultural movements, reactions and background of these ways of seeing theatre, stating its differences to classical theatre, and amending the reign of directors as sole creators. The examples given are very relevant, although, in the Romanian case, they leave space for further development of the study.

The book continues with a series of interviews with relevant European theatre makers, each of them revealing its own way of making theatre, using different aesthetics and approaches. We can find out here about Joël Pommerat's "giving meaning through representation" in an excellent interview conducted by Mirella Patureau; about how it is false "to think that independent theatre is experimental and the so-called institutionalised is conservative" and that "text is no longer the centre of theatre" as Armin Petras/Fritz Kater state; or about novel adaptations in theatrical and movie structures by Kornél Mundruczó, in an interview by Andrea Tompa. Three important young Romanian directors, Gianina Cărbunariu, Catinca Drăgănescu and Bogdan Georgescu are also present in the interview section of the book. The first one already made the step from underground to mainstream, the other two are still struggling to break the classical way of thinking which defines Romanian theatre management.

In Wojtek Ziemilski interview, the Polish director defines theatre "as an event, something that happens, a type of performance where there's an occurrence,

a change happening". Nurkan Erpulat speaks about the cultural differences, migration and being a turkish director in a german cultural space.

All in all, the interview section of the book offers a very complex/precise mapp of contemporary practices of collaborative theatre making, all around Europe.

The End of Directing, The Beginning of Theatre Making and Devising in European Theatre brings up the working methods of European contemporary theatre makers that are considering the actor, playwright and director as equal members of a team, with similar creative responsibilities; in some cases the writer fuses with the director, or even the actor. Published both in Romanian and English, the book can open a very important path on reconsidering the director's place in theatre, or the importance of text in performance. As always, there is still space for other creators; the book is not claiming to cover all aspects of the problem stated, but clearly "questions the specifics of this working mode, the artistic endeavour of some of its prominent exponents".

To sum up, as a brilliant continuation of last year's *New Performing Arts Practices in Eastern Europe* (Cartier, 2014) edited also by Iulia Popovici, *The End of Directing* lays a strong foundation for other necessary critical and theoretical studies dedicated contemporary theatre.

RALUCA SAS-MARINESCU,
*Ph.D., lecturer at the Babeş-Bolyai
 University, Faculty of Theatre and Television,
 e-mail: raluca.sas@ubbcluj.ro*

“MEMORY...is worth thinking about!” Transylvania in a Kantorian Key

Performance review: *Crochiuri din Transilvania sau Melancholia Oului Negru* [*Croquis from Transylvania or The Melancholy of the Black Egg*], directed by Teresa and Andrzej Welmiński, Faculty of Theatre and Television, Babeş-Bolyai University of Cluj, Romania, 2015.

With: Denisa Blag, Irina Boboş, Liviu Bora, Andra Buicu, Diana Crăciun, Bianco Erdei, Alexandru Manea, Alina Mişoc, Oana Nemeş, Mara Opreş, Paul-Sebastian Popa, Oana Secară, Alexandra Sotirov, Ionuţ Şerban, Eduard Trifa, Diana Tuşa, Ciprian Valea, Carina Wagner, Simion Zaiţ

Professors: Ionuţ Caras, Filip Odangiu, Mara Opreş, Ferenc Sinkó

As the audience walked through the corridor of the Faculty of Theatre and Television, Babeş-Bolyai University of Cluj, towards the entrance to the Harag Studio, the venue of the most recent Teresa and Andrzej Welmiński workshop presentation, they were greeted by a series of peculiar wooden and cardboard objects designed by the students who comprise the cast. For all those acquainted with the theatrical works of the renowned Polish artist Tadeusz Kantor (1915-1990), that evening of April 9 2015, from this initial meeting with these *ready-made*, *poor objects* to the very end, must surely have been an emotional one. We could even call it a



Fig. 1: Poster of *Croquis from Transylvania* or *The Melancholy of the Black Egg*
Copyright: Teresa and Andrzej Welmiński



Figures 2 & 3: *Croquis from Transylvania or The Melancholy of the Black Egg*
Photos: Ionuț Caras

historic one, as for the first time in the history of Romanian theatre audiences had the opportunity of a “first-hand” encounter (not mediated through video recordings) with the theatrical philosophy and stage practices of the world-famous Polish artist Tadeusz Kantor and his Cricot-2 Theatre.

And what an encounter it was! Present in Cluj from 22 March to 9 April 2015, for a three-week workshop with the 2nd year students in Acting from the Faculty of Theatre and Television (professors: Ionuț Caras, Filip Odangiu, Mara Opreș, Ferenc Sinkó), Teresa and Andrzej Welmiński brought to the heart of Transylvania their vast experience and knowledge of the Kantorian theatre, as well as a complete openness to teach and a desire to understand and employ their student actors’ potential and cultural background to the advantage of the art work. It is

worth mentioning also, as a further argument in supporting the claim that we witnessed an historic event, that on April 6 2015, three days before the workshop presentation, the artistic world celebrated Tadeusz Kantor’s 100th birthday, an event marked in Cluj-Napoca by a public meeting with the two artists, close collaborators of Kantor’s for almost twenty years.

What the spectators could see on the evening of April 9 was not a theatre production *per se*. The two directors themselves avoid this term, preferring instead to refer to *Croquis from Transylvania or The Melancholy of the Black Egg* as a “presentation of the workshop results”. At the same time, what we see on stage, Teresa and Andrzej Welmiński add, are not characters, but rather “figures”, sublimated representations of the Romanian mentality and

cultural background, figures which, in Kantor's words, "bring with them their fate and destiny" and "exist at the borderline between life and death" (T. Kantor, *UmarlaKlasa-Partytura*), in the realm of our collective memory. As a result, the space of the representation, populated by bizarre objects and contraptions reminiscent of both Kantor's *poor objects* and Kurt Schwitters' *collages*, is also situated at the boundary between *present* and *past*, between *reality* and *dream*.

Through the use of the *parallel actions/spaces* technique, a trademark of the Cricot-2 Theatre ever since the 1961 production of *The Water Hen*, whose immediate effect is the presence of several simultaneous focal points on stage and a willing dissolution (to the point of absence) of a unifying plot, *Croquis from Transylvania...* emphasizes its visual dimension, becoming a *sui generis*

celebration of the cultural memory(ies) of the very specific space it illustrates. And *memory* is without a doubt a key concept of this workshop presentation. In its witty "play with Kantor" framework, evocative of Kantor's own "play with Witkacy" creative stage (1955-1974), *Croquis from Transylvania...* begins with Mara Opriș' character/figure reading from Kantor's 1988 *Memory* manifesto: "MEMORY, / memory of the past, / held in contempt / by the SOBER-MINDED / highly valued members of humankind...".

Channeling Kantor's words and belief that the stage can represent "the altar" of Memory, the workshop presentation unfolds before us the stories, legends, beliefs that together form an "X-ray photograph" of the local spirit. In a flea market-like atmosphere, each of the character/figures



Fig. 4: *Croquis from Transylvania...*
Photo: Ionuț Caras



Fig. 5: *Croquis from Transylvania...*
Photo: Ionuț Caras

“sells” his/her own story, his/her own reality, his/her own memories. Interwoven by the thread of a traditional flax bundle (“fuior”), at times joyfully, other times nostalgically (characterized by longing, “dor”), the stories blend together in a heterogeneous, yet carefully constructed, *canvas* of humanity: particular, defined by the affiliation to a certain cultural space, yet, at the same, universal.

Croquis from Transylvania or The Melancholy of The Black Egg is a remarkable artistic work for several reasons. It is, as the result of a workshop, a testament to Teresa and Andrzej Welmiński’s experience as teachers, as they managed to create an atmosphere of collaboration with their student-actors, the collective work bringing forth the best in them. At the same

time, it is undeniable proof that Tadeusz Kantor and Cricot-2 Theatre’s stage practices cannot be confined only to a certain space and time and can unquestionably “touch” actors and audiences which didn’t have the opportunity to directly witness the company’s productions. Last but not least, it is a splendid introspection into the realm of *memory*, both individual and collective, demonstrating that, as Kantor said, “MEMORY...is worth thinking about”!

EUGEN WOHL,

Postdoctoral Researcher (project POSDRU/
159/1.5/S/132400), Faculty of Letters,
Babeş-Bolyai University of Cluj
E-mail: eugenwohl@gmail.com

The Critic of Critique and Her Unrests

Book review: Miruna Runcan, *Theatre Critique: Whereto?*, Cluj Napoca, Cluj University Press, 2015

Even if one saw only the title – *Theatre Critique: Whereto?* –, without browsing inside the book's covers, the potential reader feels challenged to question about the direction theatre critique goes to. But, I will tell from the very beginning, the endeavor of Miruna Runcan, the author of the book, is a wide, integrating and instigating one, because it does not stop punctually only on the discussion about the sense

of theatrical critique, or just on a future view of it. Without recessing the subject on its whole – a notice for those who walk between the bookstore shelves and might think they see just a book addressing strictly to theatre commentators –, the author problematizes with amplitude in a synchronic and diachronic line, but also syntagmatic-paradigmatic. The theatre is seen in a larger context of cultural space



dynamics and of our identifying as a nation, in the so often invoked Europeanism. Yet not the height - observing angle, from distance, is the one that prevails, but an incisive *zoom in* is also made, to see what is going on at “the grass level” – if we are to quote the author.

The words that come back, again and again, in book's pages, are *critique spirit / the critique exercise, publics or ethics / deontology*. Essential words, otherwise, for this theme.

Forming the base of discussion, the mentioned terms are analyzed on every level, they are meticulously dissected, set on the microscope slide, until the question mark in the title transforms, along the way, into an exclamation mark, getting an imperative value. There are no verdicts given – far from a genuine intellectual, as it is she who signs *Theatre critique: whereto?*, the impulsively axiomatic pleading for a single

form of expression or for a single answer. Not few times the proceeding is contested, often the personal assertions are subjected to relativism as well, seen as multiple directions that make them vulnerable. And this very aspect of optative, of faith in *dubito*, is the one that makes interesting, believable and gives virtuosity to the opinions raised here. With a real pleasure for the frankness, but also for the intention to look back in objectivity, it can be read the chapter *Revisiting of "the Cheery Code"* (pp. 103-111). "The law codex" that defines the theatre critic's status is re-evaluated with beneficial observations and is rendered as pretext for a lucid self-criticism, not lacking a bit of irony or humor. An agreeably reading and modeling for the young talented people, as well as for inveterate ones (on which, in some cases, some dust is resting). Because as long as the public should pay attention at the captivity it enters, not quite rarely, the critic should not become a prey, too. The term of captive spectator forms a debating nucleus in multiple paragraphs and it is long examined under the chapter *The Dead Spectacle, the Captive Spectator and the Freedom of (Not) to Go to the Theatre* (pp. 115-126).

The voice of Miruna Runcan is unmistakable. On one hand because she does not let her reader for even a second without asking questions to himself, imbuing him somehow her personal unrests. And on the other hand, because she has a rhetoric which would not let you dismissive, making you wish to downright enter a dialogue as soon as possible. You are lured, seduced, manipulated in a constructive sense. You are left no choice. The debate is started and, following its course, you begin

to give lines in your mind and get commissioned, adhering to the spoken opinions or thwarting them. With arguments. Hence the warmth of the text which, although polemic and inciting here and there, is in its essence also one of closeness, drilling the reader's intimacy. In her stimulating endeavor, the author points out and then develops acute problems, or other that maybe pass unnoticed, which did not had, altogether, the close-up of the debates. This way are commented, for example, issues like the double determination between the spectacle and the critic, the doubtless necessity of a theatre critic to know the scene and, at least temporary as a practitioner, namely from within, the term of fraud in theatre (caused by the self-plagiarism, the reproduction of the same role in countless situations). Miruna Runcan does not get tired of touching, on every occasion, the peril of fixity, of stagnancy in profession and as individuality. You adhere or you may contradict the stated ideas – after all, this is the bet set by the very question in the title. "Whereto" depends on every person, depends on the way we build communities, on the direction we chose to act and, not at last, depends on the grade of involvement. There are few apparitions on Romanian book market dealing the critique theme, and aiming the target of real enquiry. And to make it in a scholastic, erudite manner, but also in a language, let us call it *for dummies*. And from this point of view, Presa Universitară Clujeană, a publishing house having the patronage of the present book, deserves appreciation.

In the end, after you have greedily browsed the displayed dilemmatic materials, whether about our public pseudo-

debates, or about the relationship of theatre and inter-culturality, or about the usefulness and the risks of mediums, well, in the end is glimpsed, with a contour more and more defined, an idea often stated between indents, too. The theatre critique (by extension, any type of critique) assumes, in its depth, also freedom. It has its origin in this state and gives you freedom. A passage that shows how can be wielded the various lanes of liberty is, without any doubts, the one we will quote hereinafter, worthy to be put on frontispiece of the "temple with theatre": "Going to the theatre should be a joy practiced in liberty. As well as to whistle in theatre, at least from time to time, should be not grossness, but a solid sign that your freedom to enjoy is drastically violated. (...) We should rather wake up and break off the chains of captivity, systematically. (...) Understanding

what is happening to us and denying our captivity" (p. 126). Because, if we would bring Camus into discussion, we would say like him that "freedom is the right of not to lie." And we could even insinuate a "to ourselves" into this truth – the right of not to lie *to ourselves*.

Miruna Runcan makes critique out of her love for theatre. It is seen – while reading – and it feels – when you enter the dialogue. It is a sentient, assumed, poignant love. And it is the *sine qua non* condition from which afterwards go the unrests and the appetite for thoroughly debates. Help yourself!

IOANA PETCU,

*Ph.D. Lecturer at Drama Department,
George Enescu University of Arts, Iași, Romania*

A Year of Celebration: The Centenary Birthday of Tadeusz Kantor (1915-1990)

Glimpses into the Activity of Cricoteka – Center for the Documentation of the Art of Tadeusz Kantor

Brief Introduction

This year, from June to July, I returned to Cracow, home of Tadeusz Kantor and his famous Cricot-2 Theatre. I had been in this beautiful city before, in 2011, spending three months at the Cricoteka Archives, at number 5 on the historical Kanonicza Street, the splendid remain of the Royal Road that used to connect the main city gate to the central square and Wawel Royal Castel. It was here, in the small rooms and cellar, with an elegant courtyard, that Tadeusz Kantor established on 19 January 1980, as the headquarters of the Cricot 2 Theatre Center (the theatre had not previously existed as an institution, being, in Kantor's words, "a wandering troupe of actors"), a *living archive* "a collection of IDEAS that were born in opposition to all that is, / in protest against the values exhibited on stages / around the world".

I walked, on a warm July morning, the tourist-filled streets of the city center towards Kanonicza Street, only to find the doors of the Archives closed and a note on the window indicating the new address: 2-4 Nadwiślańska Street, in the beautifully restored building of the former power plant of Cracow's Podgórze

District, on the right bank of the Vistula River. A new era began for Cricoteka, which opened the gates of its new and modern headquarters in September 2014. Spending two months in Cracow in the year the entire artistic community celebrates the centenary birthday of Tadeusz Kantor, I have had the opportunity to attend a series of events organized by this busy institution and what follows is an account of these events, two exhibitions (*Tadeusz Kantor Exhibition. Episode Two. Childhood and Christian Boltanski. In the Blink of an Eye*) and three workshops conducted by Andrzej Kowalczyk, Teresa and Andrzej Welmiński and Bogdan Renczyński, from a series of five gathered under the title *Very Short Lessons*.

Exhibitions

Tadeusz Kantor Exhibition. Episode Two: Childhood (6 April 2015 – 10 January 2016) is the second of a series of four exhibitions dedicated to the art of Tadeusz Kantor – *Episode One: The Collection, Episode Two: Childhood, Episode Three: Marionette, Episode Four: Sculpture* – which aim to present sculptures, objects, drawings and other archive

materials from the Cricoteka Collection. This second part is dedicated to “the motif of childhood” and it brings together both objects previously exhibited in *Episode One* (a model from *The Return of Odysseus*, *Bathing Lady*, a series of objects and props related to *The Theatre of Death*, including the stage space from *The Dead Class* etc.), as well as new ones, connected to the theme of childhood.

“At times the references to childhood are conspicuous and at times they are hinted to by clues left by the artist”, writes Natalia Zarzecka, the director of the Center, in the program of the exhibition, and the purpose was to bring together objects and mannequins – *The Horse Skeleton* and *Trolley-Hand Cart* (“Let the Artists Die”), the *Wardrobe* (“In a Little Manor House”), *The Room of Childhood* (“Wielopole, Wielopole”) etc. – , sketches (*Window* from the performance *Wielopole, Wielopole, Adaś’ door* from the performance *Wielopole, Wielopole* etc.) and photographs (photos by Aleksander Wasiliewicz from *The Mad Man and the Nun*, a postcard and photos used in *Wielopole, Wielopole* etc.) which can allow the viewer to “examine the way in which Kantor created reality by handling scraps of memory and simultaneously decode the stories inherent in the present objects”. At the same time with this exhibition, the Gallery-Studio of Tadeusz Kantor on Sienna Street focuses on displaying Kantor’s drawings in a series of exhibitions, the first two of them entitled *Little Collections* and *The Era of the Boy*.

Christian Boltanski’s In the Blink of an Eye

Deeply influenced by Tadeusz Kantor’s art, the renowned French artist Christian Boltanski – painter, photographer, sculptor,

film maker, installation artist – was invited by Cricoteka to create a “site-specific installation” meant to celebrate the memory of Tadeusz Kantor and the activity of the Cricot-2 Theatre.

In the spacious exhibition room on the 3rd floor of the new Cricoteka building, Boltanski created a profound installation, an essay on memory, art, remembrance, on the perennial quality of nature and the ephemerality of human existence. As we approached to the exhibition room, we could feel a strong smell of fresh flowers, grass and hay and hear the sounds of bells. The floors of the space are almost entirely covered by green grass, with flower petals scattered all around. This green pasture, a symbol of the immensity of nature, of its unspoiled beauty, is “flanked” on two ends by two very modern technological devices, a screen projecting bells moved by the wind in a desert landscape at one end, and, at the other, a series of nine electronic chronometers displaying ever-changing numbers. It is a powerful image of the futility of all human endeavors to conquer time, to leave their mark on the world, to give meaning to their existence. The implacable chronometers on the wall, monitoring the time since birth of the Cricot-2 actors, is testimony of the implacability of time and the earthliness of human life that invariably seems to pass “in the blink of an eye”. In its entirety, as a work of art bearing the signature of an artist, the installation is also a meditation on art and on an artist’s desire to capture eternity in his work. After all, the green pasture that fills the air with its pregnant smell only gives the illusion of man seizing nature. As the human existence itself, art is also subjected to the passage of time.



Fig. 1: Christian Boltanski, *In the Blink of an Eye*, Cricoteka.
Photo: Studio FILMLOVE

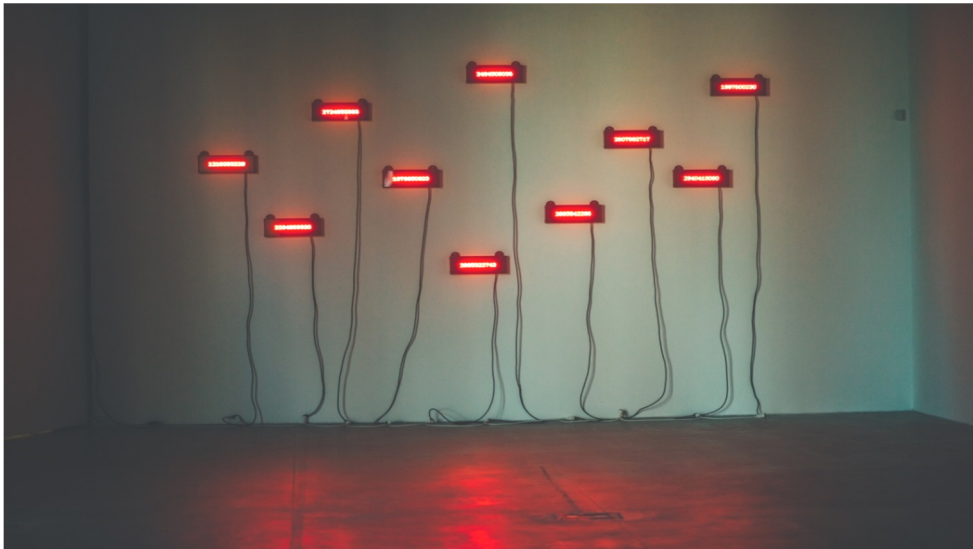

Fig. 2: Christian Boltanski, *In the Blink of an Eye*, Cricoteka.
Photo: Studio FILMLOVE

In the program of the exhibition, the curator, Joanna Zielińska, writes: "The work will be an emotional monument, subjected to the natural process of decay, governed by the diurnal rhythm and responding to the changing time and weather".

The exhibition opening, on 3 July 2015, was preceded a day earlier by a public meeting with the artist Christian Boltanski and accompanied, in the performance hall of Cricoteka, by an unnamed performance, created as a tribute to the Polish avant-garde artist Andrzej Pawłowski and his 1957 experimental film *Kineformy*.

Three Very Short Lessons

Under the title *Very Short Lessons*, Cricoteka organized, from 14 June to 14 August 2015, a series of five theatre workshops conducted by actors of the Cricot-2 Theatre. Following Ludmiła Ryba's *Secret Dealings with a Dybbuk and a Suitcase*, the second workshop from this cycle was led by the artist Andrzej Kowalczyk, with the participation of Andrzej and Teresa Welmiński and Tomasz Dobrowolski.

Under the title *Conversations at...the search for past totalities*, Andrzej Kowalczyk endeavor is at the same time very interesting and more than necessary. Taking as a starting points the existence of a set of objects created by Tadeusz Kantor and which, at the time, were not used by the artist, the workshop and the resulting public presentation (the facilitators prefer not to call it a "performance") engaged the actors in a meditation on and a quest for artistic expression. Three objects, a metal door from the production *Let the Artists Die*, a wooden board from *The Return of Odysseus* and a cannon



Fig. 3: Christian Boltanski, *In the Blink of an Eye*, Performance, Cricoteka.

Photo: Studio FILMLOVE

chassis carrying the cross from the Polish version of *Wielopole*, *Wielopole*, represent both the starting point and the axes around which the stage actions evolve. The actors construct their own artistic realities, they each manifest their individual artistic expression in connection with these preexisting objects. Whether included, as part of the participants' stage actions, or rejected and criticized, the presence of these objects within the theatrical space cannot be ignored, their artistic quality must be acknowledged, they are, at the same time, objects created by Kantor for a specific purpose and, their meaning changed completely, an organic part of the work

of art presented on stage. Working in collaboration with Andrzej and Teresa Welmiński, who familiarized the participants with the theoretical aspects of Cricot-2's methods, and Tomasz Dobrowolski, who designed the music arrangements, Andrzej Kowalczyk's complex spatial compositions managed to create an environment for artistic collaboration. The "wandering troupe" of actors – the presentation begins with the image of a bus or metro in motion – is set on journey in search of artistic essence, of individual and collective artistic expression.

The following "very short lesson", Andrzej and Teresa Welmiński's emotional *Et in Arcadia Ego*, continues the collaboration with Andrzej Kowalczyk and Tomasz Dobrowolski, and the continuation between the two workshops is ensured not only by the use of the same stage objects, but also by the existence of two "connecting" characters, a little girl dressed in red which, at times, crosses the deep end of the stage, and Andrzej Welmiński's black clad, Chaplin-like character. *Et in Arcadia Ego*, in the artists' words, a show that should be placed "somewhere between a performance and a



Fig. 4: Conversations at...the search for past totalities
©Andrzej Kowalczyk



Fig. 5: *Conversations at...the search for past totalities*
©Andrzej Kowalczyk

spectacle and might be called e.g. a *Crioting*, as its genealogy stems out of the Cricot experience, but it is not the one at the same time". Taking as a starting point Tadeusz Kantor's 1967 *Panoramic Sea Happening*, more precisely Eustachy Kossakowski's photo of the *Sea Concerto* (the first part of the five-part Kantorian happening), the artists attempted not a reconstruction of

the iconic work of art, but rather a reflection on the indisputable relationship between *reality* and *art* and the role of the latter in giving meaning to the often inextricable events of reality. By emphasizing the "universal dimension" of a real event, the artists explain, "the banal situations, often shown in the comic burlesque light, transform into a tragedy".

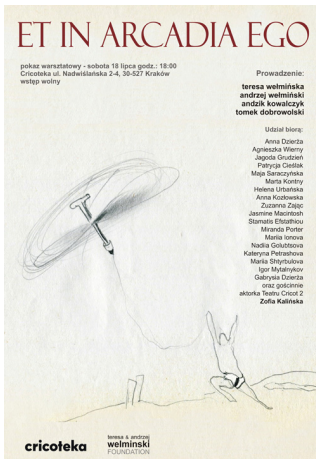

Fig. 6: Poster of *Et in Arcadia Ego*
©Teresa and Andrzej Welmiński



Fig. 7: *Et in Arcadia Ego*
©Teresa and Andrzej Welmiński

The fourth workshop of the series, *Empty places. Spaces by Tadeusz Kantor*, conducted by the actor Bogdan Renczyński, is an artistic journey into the spaces constructed and reconstructed by Tadeusz Kantor's works, his "places of memory". Divided into two thematic parts, *When I was no longer around. When I'm no longer around... – Wielopole Skrzyńskie*, which presupposed a preliminary research trip to Kantor's birthplace, and *Actor's space as a work of art. A space of a biography as a work of art*, the result of the participants' studies into the relationship between *real life* and the sometimes crucial, other times dull or trivial events that constitute it and *biography*, an artistic undertaking which implies selection, ordering and, most importantly, investing the events in the life of *the other* with artistic meaning and value, filtering them through the artist's own vision.

The cycle of "very short lessons" ended with *Primary factors*, a two-week workshop conducted by Roman Siwulak, actor of the Cricot-2 Theatre for more than twenty years. All in all, the events presented in this brief article speak volumes for Cricoteka's efforts to bring together artists and support their valuable contributions to preserving, disseminating and extending Tadeusz Kantor's invaluable cultural legacy.

EUGEN WOHL,

*Postdoctoral Researcher (project POSDRU/159/1.5/S/132400), Faculty of Letters, Babeş-Bolyai University of Cluj
E-mail: eugenwohl@gmail.com*